

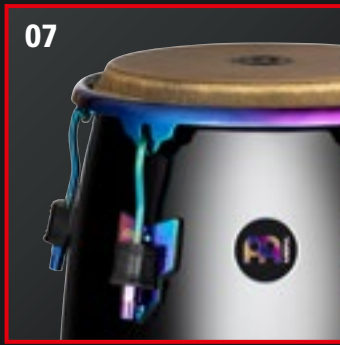

THE BOOK OF MEINL PERCUSSION 2025



WHAT'S NEW IN 2025



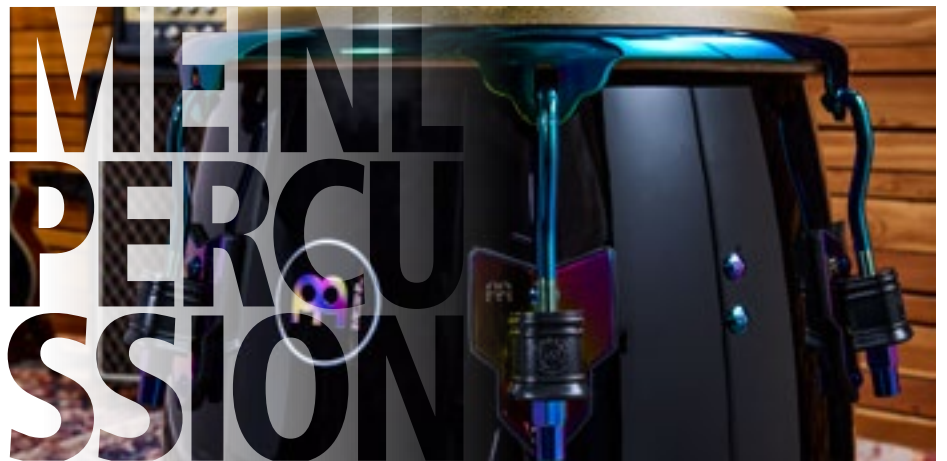

B

Bags	126
Blocks	36
Bongos	20

C

Cabasas	37
Cajons	40
Castanets	91
Chimes	94
Claves	34
Congas	06
Cowbells	29
Culture Instruments	109

D

Darbukas	110
Didgeridoos	96
Djembes	62
Doumbeks	111

F

Foot Percussion	56
Frame Drums	82

G

Güiros	34
--------	----

H

Hardware	114
----------	-----

K

Kalimbas	91
----------	----

M

Maracas	35
Merenge Güiras	37

R

Rainsticks	98
------------	----

S

Samba	101
Shakers	55 / 86 / 101
Sound Effects	92
Sticks / Beaters	124

T

Tambourines	74 / 87
Timbales	25

CONGAS

The conga is more than just a drum; it's a vessel of history and emotion. Its story begins in the heart of Africa, where drums were crafted to celebrate and connect communities. Over time, it evolved into a powerful symbol of identity and expression, blending African rhythms with Spanish and indigenous influences. The conga became the heartbeat of Afro-Cuban music.

Meinl Percussion Congas represents tradition combined with exceptional craftsmanship. We produce these premium drums using only the finest hand-selected materials. We collaborate closely with the most sought-after Conga players on a daily basis, drawing on their expertise to fine-tune every aspect of our drums and make sure that we ensure the highest quality sound and performance.

When you hear the deep, resonant tones of a Meinl Percussion Conga, you're not just hearing a drum; you're feeling the rhythm that has connected generations.





CONGA HEADS & MINI CONGAS

1



The REMO® Symmetry Conga Heads add more volume and resonance to your Conga. These are available for congas with this sign.



Black Calfskin Skyndeeep® **RHEAD-11BK** Black Calfskin Skyndeeep® **RHEAD-1134BK** Black Calfskin Skyndeeep® **RHEAD-1212BK**



Black Calfskin Skyndeeep® **RTHEAD-11BK** Black Calfskin Skyndeeep® **RTHEAD-1134BK** Black Calfskin Skyndeeep® **RTHEAD-1212BK**



Fiberskyn® **RHEAD-11NT** Fiberskyn® **RHEAD-1134NT** Fiberskyn® **RHEAD-1212NT**



Nuskyn® **RTHEAD-11NS** Nuskyn® **RTHEAD-1134NS** Nuskyn® **RTHEAD-1212NS**

2



Natural, 4 1/2" **MC100NT**

Vintage Wine Barrel, 4 1/2" **MC100VWB**

Wine Red, 4 1/2" **MC100WR**

3



CONGA-SAVER8 **CONGA-SAVER10**

4



COMES IN A SET OF 4

Set **MCR-BK**

5

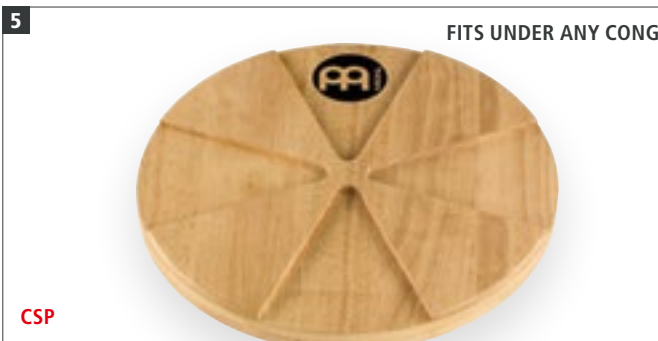

FITS UNDER ANY CONGA

CSP

1 REMO® SYMMETRY CONGA HEADS

SIZES **RHEAD-11:** 11" Quinto; SSR-Rim
RHEAD-1134: 11 3/4" Conga; SSR-Rim
RHEAD-1212: 12 1/2" Tumba; SSR-Rim
RTHEAD-11: 11" Quinto; TTR-Rim
RTHEAD-1134: 11 3/4" Conga; TTR-Rim
RTHEAD-1212: 12 1/2" Tumba; TTR-Rim
FIT FOR **RHEAD:** MCC, MEC, MP, FC, MSA, WKT, WCO, BWC, DG, RS, S
RTHEAD: LC, MTC
FEATURE For more volume and resonance
FINISHES **BK:** Black Calfskin Skyndeeep®
NS: Nuskyn®
NT: Fiberskyn®

FEATURES Contains every feature of a regular Meinl conga, at 2/5 the size
Tunable buffalo skin head with 4 chrome lugs and rounded rim
Great for spontaneous jam sessions or drum circles
COLOURS **NT:** Natural
VWB: Vintage Wine Barrel
WR: Wine Red

3 CONGA SAVERS

SIZES **CONGA-SAVER8:** for 8 mm tuning lugs
CONGA-SAVER10: for 10 mm tuning lugs
FEATURES Placed over the conga lugs to prevent them from damaging and scratching the shell
Conga remains fully tunable

4 CONGA RISERS

MATERIAL Sturdy rubber
FEATURES Raise your drums off the floor to allow maximum sound projection
Provide a stable base on any surface
Come in a set of four
Flexible construction
COLOUR **BK:** Black

5 CONGA SOUND PLATE

SIZE 13 1/4"
MATERIAL Siam Oak (*Hevea brasiliensis* Muell.-Arg.)
FEATURE Provides a hard sound reflective surface under your conga

2 MINI CONGAS

SIZE 4 1/2" wide, 11" tall
MATERIALS Siam Oak (*Hevea brasiliensis* Muell.-Arg.)
Buffalo skin heads

6 **NEW** **REMO HEADS AVAILABLE** **PHANTOM BLACK**

11" **S11PBK** 11 3/4" **S1134PBK** 12 1/2" **S1212PBK**

7 **REMO HEADS AVAILABLE** **VINTAGE BLACK**

11" **WCO11VBK-M** 11 3/4" **WCO1134VBK-M** 12 1/2" **WCO1212VBK-M**

VINTAGE BROWN

11" **WCO11VBR-M** 11 3/4" **WCO1134VBR-M** 12 1/2" **WCO1212VBR-M**

VINTAGE RED

11" **WCO11VR-M** 11 3/4" **WCO1134VR-M** 12 1/2" **WCO1212VR-M**

CONGAS

6 SPECTRUM SERIES CONGAS

- SIZES** **S11:** 11" Quinto, 30" tall
S1134: 11 3/4" Conga, 30" tall
S1212: 12 1/2" Tumba, 30" tall
- MATERIALS** Three ply Siam Oak
(Hevea brasiliensis Muell.-Arg.)
 True Skin Buffalo Heads
- FEATURES** 10 mm strong tuning lugs
 4 mm rounded SSR-Rims
 Spectrum Series hardware
- INCLUDES** Meinl Conga Savers
 Meinl Conga Handle
 Meinl Soundpads
 Accessory pouch
 L-shaped tuning key
 Tune Up Oil
- COLOUR** **PBK:** Phantom Black

7 WOODCRAFT SERIES WCO CONGAS

- SIZES** **WCO11:** 11" Quinto, 30" tall
WCO1134: 11 3/4" Conga, 30" tall
WCO1212: 12 1/2" Tumba, 30" tall
- MATERIALS** Three ply American White Ash
(Fraxinus americana L.)
 True Skin Buffalo Heads
- FEATURES** 10 mm strong tuning lugs
 4 mm rounded SSR-Rims
 Chrome plated hardware
- INCLUDES** Meinl Conga Savers
 Meinl Conga Handle
 Meinl Soundpads
 Accessory pouch
 L-shaped tuning key
 Tune Up Oil
- COLOURS** **VBK-M:** Vintage Black
VBR-M: Vintage Brown
VR-M: Vintage Red
- FINISH** Matte

PROFESSIONAL CONGA STAND WITH WHEELS
 (SEE PAGE 115)



TMPC

SIGNATURE CONGAS

1 **NEW** REMO® BLACK CALFSKIN SKYNDDEEP® HEADS



11" **WKT11BW** 11 3/4" **WKT1134BW** 12 1/2" **WKT1212BW**

NEW REMO® BLACK CALFSKIN SKYNDDEEP® HEADS



11" **WKT11ES** 11 3/4" **WKT1134ES** 12 1/2" **WKT1212ES**

From Santurce, Puerto Rico, **William Kachiro Thompson** is one of the most in-demand conga and bongo players today. As a prolific recording and touring artist, Kachiro needs drums that will deliver in a wide variety of musical situations. Inside or outside, in an intimate venue or a big stadium, in the studio or while on tour, Kachiro needs instruments that feel good when he plays them and that transmit the nuances and intensity of his playing. With more than 500 recordings during his career so far, Kachiro's sound and playing style has become a staple in modern-day salsa music produced in the salsa capitals of the world, like San Juan (Puerto Rico), Miami, and New York. The Artist Series Congas and Bongos by MEINL are just what Kachiro needs in terms of look and sound. With an elegant shape of the drum, these drums will accompany Kachiro during his busy recording and playing schedule, always delivering the sound he needs.



Kachiro Thompson

1 **WILLIAM "KACHIRO" THOMPSON SIGNATURE CONGAS**

SIZES **WKT11:** 11" Quinto, 30" tall
WKT1134: 11 3/4" Conga, 30" tall
WKT1212: 12 1/2" Tumba, 30" tall

MATERIALS REMO® Black Calfskin Skynddeep® Heads
BW: Three ply New Zealand Pine Wood
ES: Premium Fiberglass

FEATURES 10 mm strong tuning lugs
 4 mm rounded SSR-Rims
 Chrome plated hardware

INCLUDES Meinl Conga Savers
 Meinl Conga Handle
 Meinl Soundpads
 Accessory pouch
 L-shaped tuning key
 Tune Up Oil

COLOURS **BW:** Blue Wave
ES: Electric Sky

WILLIAM "KACHIRO" THOMPSON SIGNATURE BONGOS (SEE PAGE 20)



WKT400BW

WKT400ES

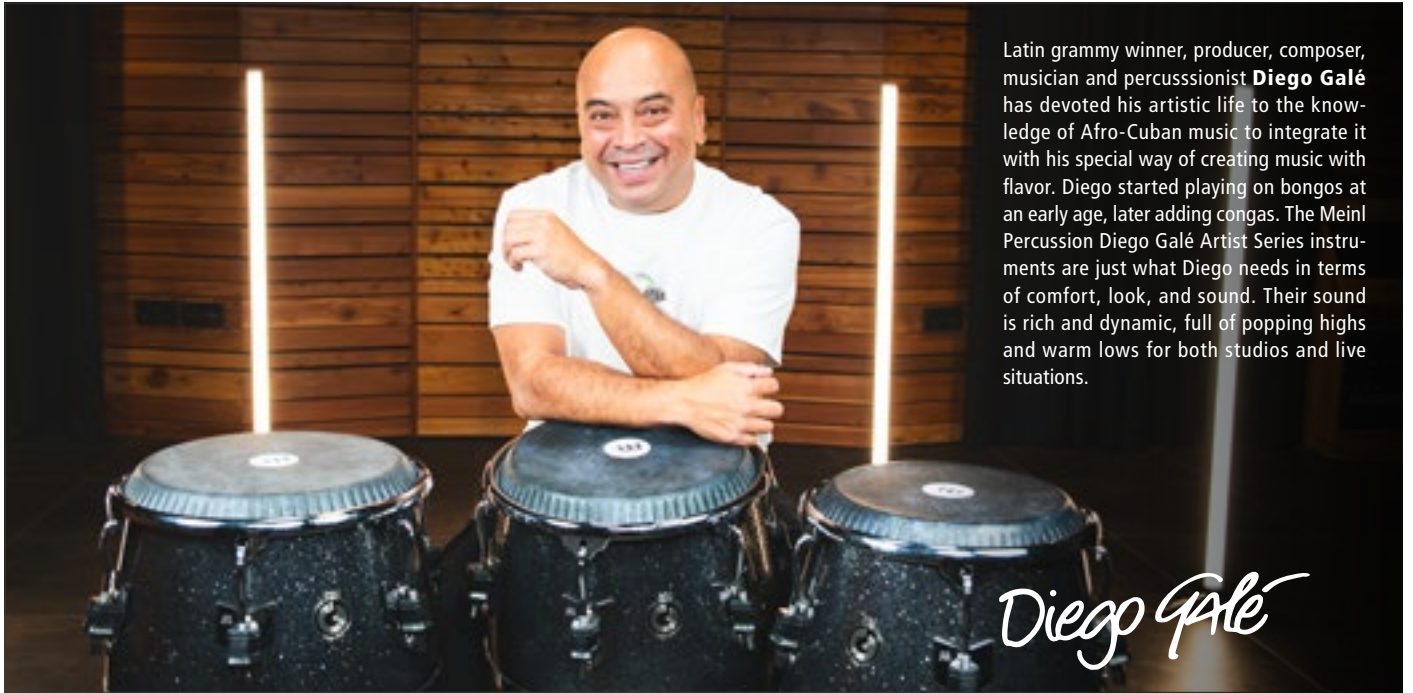

Latin grammy winner, producer, composer, musician and percussianist **Diego Galé** has devoted his artistic life to the knowledge of Afro-Cuban music to integrate it with his special way of creating music with flavor. Diego started playing on bongos at an early age, later adding congas. The Meinl Percussion Diego Galé Artist Series instruments are just what Diego needs in terms of comfort, look, and sound. Their sound is rich and dynamic, full of popping highs and warm lows for both studios and live situations.

Diego Galé

2 **REMO® BLACK CALFSKIN SKYNDEEP® HEADS** **REMO® FIBERSKYN® HEADS**



NEW



11" **DG11MS** 11 3/4" **DG1134MS** 12 1/2" **DG1212MS**



11" **DGR11CW** 11 3/4" **DGR1134CW** 12 1/2" **DGR1212CW**

2 DIEGO GALÉ SIGNATURE CONGAS

- SIZES**
DG11: 11" Quinto, 28" tall
DG1134: 11 3/4" Conga, 28" tall
DG1212: 12 1/2" Tumba, 28" tall
DGR11: 11" Quinto, 30" tall
DGR1134: 11 3/4" Conga, 30" tall
DGR1212: 12 1/2" Tumba, 30" tall
- MATERIALS**
DG: Premium Fiberglass
 REMO® Black Calfskin Skyndeeep® Heads
DGR: Two ply Chamchuri Wood
 REMO® Fiberskyn® Heads
- FEATURES**
 10 mm strong tuning lugs
 4 mm rounded SSR-Rims
DG: Chrome plated hardware
DGR: Brushed nickel hardware

- INCLUDES** Meinl Conga Savers
 Meinl Conga Handle
 Meinl Soundpads
 Accessory pouch
 L-shaped tuning key
 Tune Up Oil
- COLOURS** **CW:** Chamchuri Wood
MS: Midnight Star
- FINISH** **CW:** High gloss

DIEGO GALÉ SIGNATURE BONGOS
(SEE PAGE 20)



DG400MS



DGR400CW

SIGNATURE CONGAS

1 **NEW** REMO® FIBERSKYN® HEADS

REMO HEADS AVAILABLE



11" **RS11PW** 11 3/4" **RS1134PW** 12 1/2" **RS1212PW**



Grammy nominated artist **Roberto Serrano** is a recognized Mexican percussionist and drummer whose constant search for musical excellence has allowed him the privilege of working with highly recognized musicians like Alvaro Lopez, Michael Landau, Abraham Laboriel and John Peña. Currently Roberto is playing with Luis Miguel a Mexican singer and record producer. His Artist Series signature congas are specially designed with Roberto Serrano. Outfitted with REMO® Fiberskyn Heads and features a Pearl White finish. Available as 11" quinto, 11 3/4" conga, 12 1/2" tumba.

Roberto Serrano Cruz



Ramon Mongo Santamaria was without a doubt one of the most respected conga players ever, and a pioneer of modern Latin Jazz. Ramon recorded dozens of legendary percussion albums. Mongo has inspired more percussionists around the globe than any other conguero. Mongo Santamaria died at the Baptist Hospital in Miami, USA in February 2003. He was 85 years old. It is with great appreciation and deepest respect that we honour our friend and his life's work with his MEINL Artist Series Mongo Santamaria Congas.

Ramon Mongo Santamaria

2 REMO® TRUE SKIN BUFFALO HEADS

REMO HEADS AVAILABLE



11" **MSA11AWA** 11 3/4" **MSA1134AWA** 12 1/2" **MSA1212AWA**

<p>1 ROBERTO SERRANO SIGNATURE CONGAS</p> <p>SIZES RS11: 11" Quinto, 30" tall RS1134: 11 3/4" Conga, 30" tall RS1212: 12 1/2" Tumba, 30" tall</p> <p>MATERIALS Three ply Siam Oak (<i>Hevea brasiliensis</i> Muell.-Arg.) REMO® Fiberskyn® Heads</p> <p>FEATURES 10 mm strong tuning lugs 4 mm rounded SSR-Rims Brushed nickel hardware</p> <p>INCLUDES Meinl Conga Savers Meinl Conga Handle Meinl Soundpads Accessory pouch L-shaped tuning key Tune Up Oil</p> <p>COLOUR PW: Pearl White</p>	<p>2 RAMON "MONGO" SANTAMARIA SIGNATURE CONGAS</p> <p>SIZES MSA11: 11" Quinto, 30" tall MSA1134: 11 3/4" Conga, 30" tall MSA1212: 12 1/2" Tumba, 30" tall</p> <p>MATERIALS Two ply American White Ash (<i>Fraxinus americana</i> L.) True Skin Buffalo Heads</p> <p>FEATURES 10 mm strong tuning lugs 4 mm rounded SSR-Rims Gold tone hardware</p> <p>INCLUDES Meinl Conga Savers Meinl Soundpads Accessory pouch L-shaped tuning key Tune Up Oil</p> <p>COLOUR AWA: American White Ash FINISH High gloss</p>
--	---

ROBERTO SERRANO SIGNATURE BONGO (SEE PAGE 20)



RS400PW

3
TRUE SKIN BUFFALO HEADS

11"
LC11NT-M
11 3/4"
LC1134NT-M
12 1/2"
LC1212NT-M
REMO® NUSKYN® HEADS

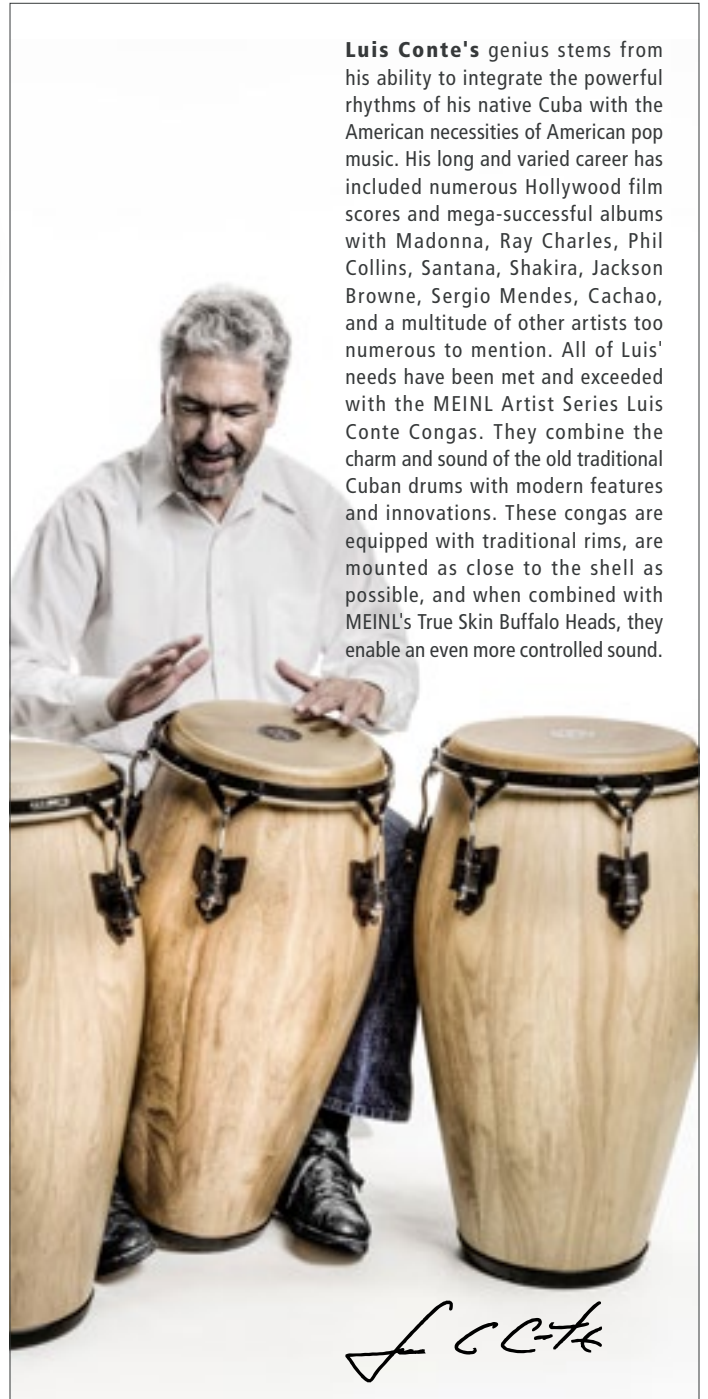
11"
LCR11NT-M
11 3/4"
LCR1134NT-M
12 1/2"
LCR1212NT-M

Luis Conte's genius stems from his ability to integrate the powerful rhythms of his native Cuba with the American necessities of American pop music. His long and varied career has included numerous Hollywood film scores and mega-successful albums with Madonna, Ray Charles, Phil Collins, Santana, Shakira, Jackson Browne, Sergio Mendes, Cachao, and a multitude of other artists too numerous to mention. All of Luis' needs have been met and exceeded with the MEINL Artist Series Luis Conte Congas. They combine the charm and sound of the old traditional Cuban drums with modern features and innovations. These congas are equipped with traditional rims, are mounted as close to the shell as possible, and when combined with MEINL's True Skin Buffalo Heads, they enable an even more controlled sound.

3 LUIS CONTE SIGNATURE CONGAS

SIZES **LC(R)11:** 11" Quinto, 30" tall
LC(R)1134: 11 3/4" Conga, 30" tall
LC(R)1212: 12 1/2" Tumba, 30" tall

MATERIALS Two ply Siam Oak
(Hevea brasiliensis Muell.-Arg.)
LC: True Skin Buffalo Heads
LCR: REMO® Nuskyn® Heads

FEATURES 8 mm strong tuning lugs
 5 mm traditional TTR-Rims
 Black powder coated hardware

INCLUDES Meinl Conga Savers
 Meinl Soundpads
 Accessory pouch
 L-shaped tuning key
 Tune Up Oil

COLOUR **NT:** Natural
FINISH Matte

LUIS CONTE SIGNATURE BONGOS
 (SEE PAGE 20)

LC300NT-M

LCR300NT-M

WOODCRAFT TRADITIONAL & FLOATUNE CONGAS

1

ZEBRA FINISHED ASH



11"
WC11ZFA-M

11 3/4"
WC1134ZFA-M

12 1/2"
WC1212ZFA-M

PROFESSIONAL CONGA BAGS
(SEE PAGE 127)



MCOB-11

MCOB-1134

MCOB-1212

2

NATURAL



10"
FL10NT

11"
FL11NT

12"
FL12NT

13"
FL13NT

THE FLOATUNE TUNING SYSTEM
ALLOWS THE SHELL TO
VIBRATE FREELY



1 WOODCRAFT TRADITIONAL SERIES CONGAS

SIZES WC11: 11" Quinto, 30" tall
WC1134: 11 3/4" Conga, 30" tall
WC1212: 12 1/2" Tumba, 30" tall

MATERIALS Three ply American White Ash (*Fraxinus americana* L.)
True Skin Buffalo Heads

FEATURES 10 mm strong tuning lugs
5 mm traditional TTR-Rims
Chrome plated hardware

INCLUDES Meinl Conga Savers
Meinl Conga Handle
Meinl Soundpads
Accessory pouch
L-shaped tuning key
Tune Up Oil

COLOUR Zebra Finished Ash
FINISH Matte

2 FLOATUNE SERIES CONGAS

SIZES FL10: 10" Nino, 30" tall
FL11: 11" Quinto, 30" tall
FL12: 12" Conga, 30" tall
FL13: 13" Tumba, 30" tall

MATERIALS Two ply Siam Oak (*Hevea brasiliensis* Muell.-Arg.)
True Skin Buffalo Heads

FEATURES Floatune Tuning System
10 mm strong tuning lugs
4 mm rounded SSR-Rims
Chrome plated hardware

INCLUDES Meinl Conga Savers
Meinl Conga Handle
Meinl Soundpads
Accessory pouch
L-shaped tuning key
Tune Up Oil

COLOUR Natural
FINISH High gloss

PROFESSIONAL & FIBERCRAFT CONGAS



3 **REMO HEADS AVAILABLE**

NATURAL **BROWN BURL**

11" **MP11NT** 11 3/4" **MP1134NT** 12 1/2" **MP1212NT** 11" **MP11BB** 11 3/4" **MP1134BB** 12 1/2" **MP1212BB**

4 **REMO HEADS AVAILABLE**

TRUE SKIN BUFFALO HEADS **REMO® BLACK CALFSKIN SKYNDDEEP® HEADS**

11" **FC11BK** 11 3/4" **FC1134BK** 12 1/2" **FC1212BK** 11" **FCR11BK** 11 3/4" **FCR1134BK** 12 1/2" **FCR1212BK**

3 PROFESSIONAL SERIES CONGAS

- SIZES** **MP11:** 11" Quinto, 30" tall
MP1134: 11 3/4" Conga, 30" tall
MP1212: 12 1/2" Tumba, 30" tall
- MATERIALS** Two ply Siam Oak
(Hevea brasiliensis Muell.-Arg.)
 True Skin Buffalo Heads
- FEATURES** 10 mm strong tuning lugs
 4 mm rounded SSR-Rims
 Chrome plated hardware
- INCLUDES** Meinl Conga Savers
 Meinl Conga Handle
 Meinl Soundpads
 Accessory pouch
 L-shaped tuning key
 Tune Up Oil
- COLOURS** **BB:** Brown Burl
NT: Natural
- FINISH** High gloss

4 FIBERCRAFT SERIES CONGAS

- SIZES** **FC(R)11:** 11" Quinto, 30" tall
FC(R)1134: 11 3/4" Conga, 30" tall
FC(R)1212: 12 1/2" Tumba, 30" tall
- MATERIALS** Premium fiberglass
FC: True Skin Buffalo Heads
FCR: Remo® Black Calfskin Skynddeep® Heads
- FEATURES** 10 mm strong tuning lugs
 4 mm rounded SSR-Rims
 Chrome plated hardware
- INCLUDES** Meinl Conga Savers
 Meinl Conga Handle
 Meinl Soundpads
 Accessory pouch
 L-shaped tuning key
 Tune Up Oil
- COLOUR** **BK:** Black

REMO® SYMMETRY CONGA HEADS (SEE PAGE 06)



The REMO® Symmetry Conga Heads add more volume and resonance to your Conga. These are available for congas with this sign.



MARATHON® EXCLUSIVE & TRADITIONAL CONGAS



MARATHON® SERIES CONGAS

1 2 3 4

PATENTS Steely-II patents:
 L-shaped leg and metal spike attachment (DE, TH, US patent)
 U-shaped notch (US patent)
 Ergonomic arched rubber bracing (CN, DE, TH, US patent)
 Notches for quick height adjustability (DE patent)

1 MARATHON® EXCLUSIVE SERIES CONGAS

SIZES **MEC(R)11:** 11" Quinto, 30" tall
MEC(R)1134: 11 3/4" Conga, 30" tall
MEC(R)1212: 12 1/2" Tumba, 30" tall
MATERIALS **MEC(R)11NT, MEC(R)1134NT, MEC(R)1212NT:** Two ply Siam Oak (*Hevea brasiliensis* Muell.-Arg.)

MEC11WRP, MEC1134WRP, MEC1212WRP: Two ply New Zealand Pine Wood
MEC: True Skin Buffalo Heads
MECR: REMO® Fiberskyn® Heads
FEATURES 8 mm strong tuning lugs
 2.6 mm rounded SSR-Rims
CH: Chrome plated hardware
G: Gold tone hardware
INCLUDES Steely II Conga Stand (patented)
 Meinl Conga Savers
 Meinl Conga Handle
 Meinl Sound Pads
 Accessory pouch
 L-shaped tuning key
 Tune Up Oil
COLOURS **NT:** Natural
WR: Wine Red
FINISH High gloss

2 MARATHON® TRADITIONAL SERIES CONGAS

SIZES **MTCR11:** 11" Quinto, 30" tall
MTCR1134: 11 3/4" Conga, 30" tall
MTCR1212: 12 1/2" Tumba, 30" tall
MATERIALS Two ply Siam Oak (*Hevea brasiliensis* Muell.-Arg.)
 REMO® Black Calfskin Skyndee® Heads
FEATURES 8 mm strong tuning lugs
 5 mm traditional TTR-Rims
 Black powder coated hardware
INCLUDES Steely II Conga Stand (patented)
 Meinl Conga Savers
 Meinl Conga Handle
 Meinl Sound Pads
 Accessory pouch
 L-shaped tuning key
 Tune Up Oil
COLOUR **WR:** Wine Red
FINISH High gloss

MARATHON® DESIGNER & CLASSIC CONGAS



2 **REMO HEADS AVAILABLE**

REMO® BLACK CALFSKIN SKYNDEEP® HEADS

11" **MTCR11WR** 11 3/4" **MTCR1134WR** 12 1/2" **MTCR1212WR**

3 **REMO HEADS AVAILABLE**

TRUE SKIN BUFFALO HEADS

11" **MCC11LB** 11 3/4" **MCC1134LB** 12 1/2" **MCC1212LB**

4 **REMO HEADS AVAILABLE**

NATURAL

11" **MCC11NT** 11 3/4" **MCC1134NT** 12 1/2" **MCC1212NT**

SUPER NATURAL

11" **MCC11SNT-M** 11 3/4" **MCC1134SNT-M** 12 1/2" **MCC1212SNT-M**

COFFEE BURST

11" **MCC11CB** 11 3/4" **MCC1134CB** 12 1/2" **MCC1212CB**

3 MARATHON® DESIGNER SERIES CONGAS

- SIZES** **MCC11:** 11" Quinto, 30" tall
MCC1134: 11 3/4" Conga, 30" tall
MCC1212: 12 1/2" Tumba, 30" tall
- MATERIALS** Two ply Siam Oak
(Hevea brasiliensis Muell.-Arg.)
 True Skin Buffalo Heads
- FEATURES** 8 mm strong tuning lugs
 2.6 mm rounded SSR-Rims
 Black powder coated hardware
- INCLUDES** Steely II Conga Stand (patented)
 Meinl Conga Savers
 Accessory pouch
 L-shaped tuning key
 Tune Up Oil
- COLOUR FINISH** **LB:** Leopard Burl High gloss

4 MARATHON® CLASSIC SERIES CONGAS

- SIZES** **MCC11:** 11" Quinto, 30" tall
MCC1134: 11 3/4" Conga, 30" tall
MCC1212: 12 1/2" Tumba, 30" tall
- MATERIALS** Two ply Siam Oak
(Hevea brasiliensis Muell.-Arg.)
 True Skin Buffalo Heads
- FEATURES** 8 mm strong tuning lugs
 2.6 mm rounded SSR-Rims
 Black powder coated hardware
- INCLUDES** Steely II Conga Stand (patented)
 Meinl Conga Savers
 Accessory pouch
 L-shaped tuning key
 Tune Up Oil
- COLOURS** **CB:** Coffee Burst, high gloss
NT: Natural, high gloss
SNT-M: Super Natural, matte

REMO® SYMMETRY CONGA HEADS (SEE PAGE 06)



The REMO® Symmetry Conga Heads add more volume and resonance to your Conga. These are available for congas with this sign.



HEADLINER® & HEADLINER® TRADITIONAL CONGAS



1 HEADLINER® SERIES CONGAS

SIZES	HC10: 10" Nino, 28" tall HC11: 11" Quinto, 28" tall HC12: 12" Conga, 28" tall
MATERIALS	Siam Oak (<i>Hevea brasiliensis</i> Muell.-Arg.) Hand selected buffalo heads
FEATURES	8 mm strong tuning lugs Original Meinl style tuning brackets 2 mm rounded rims Black powder coated hardware
INCLUDES	Height adjustable basket stands (patented) with quick set up system Tuning key
COLOURS	PBK-M: Phantom Black SNT-M: Super Natural VWB-M: Vintage Wine Barrel
FINISH	Matte

PATENTS	Basket stand patents: Ergo arched rubber bracing (CN, DE, TH, US patent) U-shaped notch (US patent) L-shaped leg (DE patent)
----------------	---

2 HEADLINER® TRADITIONAL SERIES CONGAS

SIZES	HTC10: 10" Nino, 28" tall HTC11: 11" Quinto, 28" tall HTC12: 12" Conga, 28" tall
MATERIALS	Siam Oak (<i>Hevea brasiliensis</i> Muell.-Arg.) Hand selected buffalo heads
FEATURES	8 mm strong tuning lugs Original Meinl style tuning brackets 5 mm traditional TTR-Rims Black powder coated hardware
INCLUDES	Height adjustable basket stands (patented) with quick set up system Tuning key
COLOUR	WB-M: Walnut Brown
FINISH	Matte
PATENTS	Basket stand patents: Ergo arched rubber bracing (CN, DE, TH, US patent) U-shaped notch (US patent) L-shaped leg (DE patent)

3



Set, 10" & 11"
HC555NT



Set, 11" & 12"
HC512NT

NATURAL



Set, 10" & 11"
HC555VSB

VINTAGE SUNBURST



Set, 10" & 11"
HC888NT

THE BONGO MOUNT IS EASY MOUNTABLE ON OUR CONGA DOUBLE STANDS (SEE PAGE 114)



THBM



Set, 11" & 12"
HC512VSB



Set, 11" & 12"
HC812NT



Set, 10" & 11"
HC888VSB



Set, 11" & 12"
HC812VSB

3 HEADLINER® SERIES CONGA SETS

- SIZES** **HC555, HC888:** 10" Nino & 11" Quinto, 28" tall
HC512, HC812: 11" Quinto & 12" Conga, 28" tall
- MATERIALS** Siam Oak (*Hevea brasiliensis* Muell.-Arg.)
Hand selected buffalo heads
- FEATURES** 8 mm strong tuning lugs
Original Meinl style tuning brackets
2 mm rounded rims
Black powder coated hardware
- INCLUDES** Tuning key
HC555, HC512: Height adjustable basket stands (patented) with quick set up system
HC888, HC812: Height adjustable double braced tripod stand
- COLOURS** **NT:** Natural
VSB: Vintage Sunburst
- FINISH** High gloss

- PATENTS** Basket stand patents:
Ergo arched rubber bracing (CN, DE, TH, US patent)
U-shaped notch (US patent)
L-shaped leg (DE patent)

BONGGOS





The bongo drum is a little instrument with a tremendous soul. Its roots can be found in the vibrant streets of Cuba, where indigenous, Spanish, and African sounds blended to create a vibrant musical tapestry. The larger drum, the "hembra", and the smaller drum, the "macho", add vitality to the song by making bright, crisp sounds that cut through the atmosphere.

Meinl bongos are expertly made with a commitment to quality, fusing imagination and accuracy. Our bongos guarantee to enhance each beat and stimulate your musical journey, regardless of your level of experience with drumming – whether you're a beginner learning the art or an accomplished performer honing your craft.

BONGO HEADS & BONGOS

1

REMO HEADS AVAILABLE

The REMO® R-Series Bongo Heads add more volume and resonance to your Bongo. These are available for bongos with this sign.



Fiberskyn®
RHEAD-7NT

Fiberskyn®
RHEAD-812NT

Nuskyn®
RHEAD-7NS

Nuskyn®
RHEAD-812NS

Black Calfskin Skyndee®
RHEAD-7BK

Black Calfskin Skyndee®
RHEAD-812BK

2

REMO HEADS AVAILABLE

NEW



L. Conte

Natural, matte, 6 3/4" & 8"
LC300NT-M

Natural, matte, 6 3/4" & 8"
LCR300NT-M

TRADITIONAL TTR-RIM

3

REMO HEADS AVAILABLE

NEW



Diego Galé

Midnight Star, 7" & 8 1/2"
DG400MS

Natural, high gloss, 7" & 8 1/2"
DGR400CW

4

REMO HEADS AVAILABLE

NEW



Kachiro Thompson

Blue Wave, 7" & 8 1/2"
WKT400BW

Electric Sky, 7" & 8 1/2"
WKT400ES

5

REMO HEADS AVAILABLE

NEW



Roberto Serrano

Pearl White, 7" & 8 1/2"
RS400PW

6

REMO HEADS AVAILABLE



Vintage Black, matte, 7" & 8 1/2"
WB400VBK-M

Vintage Brown, matte, 7" & 8 1/2"
WB400VBR-M

Vintage Red, matte, 7" & 8 1/2"
WB400VR-M

1 REMO® R-SERIES BONGO HEADS

SIZES **RHEAD-7:** 7" Macho
RHEAD-812: 8 1/2" Hembra

FIT FOR LC300, FFB400, FWB400, CS400, WB400, BWB400, WKT400, RS400, DG400, S400

FEATURE For more volume and resonance

FINISHES **BK:** Black Calfskin Skyndee®; **NS:** Nuskyn®; **NT:** Fiberskyn®

2 LUIS CONTE SIGNATURE BONGOS

SIZES 6 3/4" Macho & 8" Hembra

MATERIALS Siam Oak (*Hevea brasiliensis* Muell.-Arg.)
LC300NT-M: True Skin Cow Heads
LCR300NT-M: REMO® Nuskyn® Heads

FEATURES Solid woodblock connection; Black powder coated hardware; 8 mm strong tuning lugs; 5 mm traditional TTR-Rims

INCLUDES Accessory pouch; L-shaped tuning key; Tune Up Oil

SIGNATURE BONGOS

3 4 5

SIZES 7" Macho & 8 1/2" Hembra

FEATURES Meinl Free Ride Suspension System; 8 mm strong tuning lugs; 3 mm rounded SSR-Rims; Resonance Shaping Area

INCLUDES Accessory pouch; L-shaped tuning key; Tune Up Oil

3 DIEGO GALÉ SIGNATURE BONGOS

MATERIALS **DG400MS:** Premium Fiberglass
REMO® Black Calfskin Skyndee® Heads
DGR400CW: Chamchuri Wood
REMO® Fiberskyn® Heads

FEATURES **DG400MS:** Chrome plated hardware
DGR400CW: Brushed nickel hardware

4 WILLIAM "KACHIRO" THOMPSON SIGNATURE BONGOS

MATERIALS **WKT400BW:** New Zealand Pine Wood
WKT400ES: Premium Fiberglass
REMO® Black Calfskin Skyndee® Heads

FEATURE Chrome plated hardware

5 ROBERTO SERRANO SIGNATURE BONGO

MATERIALS Siam Oak (*Hevea brasiliensis* Muell.-Arg.)
REMO® Fiberskyn® Heads

FEATURE Brushed nickel hardware

WOODCRAFT & PROFESSIONAL SERIES WOOD BONGOS

6 7 8 9

FEATURES Meinl Free Ride Suspension System; Chrome plated hardware; 8 mm strong tuning lugs; Resonance Shaping Area

INCLUDES Accessory pouch; L-shaped tuning key; Tune Up Oil



7

REMO HEADS AVAILABLE

Natural, 7" & 8 1/2"
BWB400

8

Antique Mahogany Burst, high gloss, 7" & 9"
WB500AMB

Zebra Finished Ash, matte, 7" & 9"
WB500ZFA-M

CHROME PLATED
5 MM TRADITIONAL TTR RIM

9

REMO HEADS AVAILABLE

Natural, high gloss, 7" & 8 1/2"
FWB400NT

Brown Burl, high gloss, 7" & 8 1/2"
FWB400BB

10

REMO HEADS AVAILABLE

NEW
Spectrum, 7" & 8 1/2"
S400PBK

Cherry Red, high gloss, 7" & 8 1/2"
FWB400CR

Gold Amber Sunburst, high gloss, 7" & 8 1/2"
FWB400GAB

11

MINI!

Super Natural, matte, 3 1/2" & 4 1/4"
FWB100SNT-M

12

REMO HEADS AVAILABLE

Black, 7" & 8 1/2"
FFB400BK

TRUE SKIN
COW HEADS

Black, 7" & 8 1/2"
FFBR400BK

REMO® BLACK
CALFSKIN
SKYNDDEEP® HEADS

PREMIUM FIBERGLASS

6 WOODCRAFT SERIES
WB400 WOOD BONGOS
SIZES 7" Macho & 8 1/2" Hembra
MATERIALS American White Ash (*Fraxinus americana* L.)
True Skin Cow Heads
FEATURE 3 mm rounded SSR-Rims

7 WOODCRAFT SERIES
BWB400 WOOD BONGO
SIZES 7" Macho & 8 1/2" Hembra
MATERIALS European Birch (*Betula pendula*)
Hand selected cow heads
FEATURES Natural finish European Birch shells;
3 mm rounded SSR-Rims
COLOUR Natural

8 WOODCRAFT SERIES
WB500 WOOD BONGOS
SIZES 7" Macho & 9" Hembra

MATERIALS American White Ash (*Fraxinus americana* L.)
True Skin Cow Heads
FEATURE 5 mm traditional TTR-Rims

9 PROFESSIONAL SERIES WOOD BONGOS
SIZES 7" Macho & 8 1/2" Hembra
MATERIALS Siam Oak (*Hevea brasiliensis* Muell.-Arg.)
True Skin Cow Heads
FEATURE 3 mm rounded SSR-Rims

10 SPECTRUM SERIES BONGO
SIZES 7" Macho & 8 1/2" Hembra
MATERIALS Siam Oak (*Hevea brasiliensis* Muell.-Arg.)
True Skin Cow Heads
FEATURES Meinl Free Ride Suspension System;
Spectrum Series hardware; 8 mm strong tuning lugs;
3 mm rounded SSR-Rims
INCLUDES Accessory pouch; L-shaped tuning key; Tune Up Oil

11 MINI WOOD BONGO
SIZES 3 1/2" Macho & 4 1/4" Hembra
MATERIALS Siam Oak (*Hevea brasiliensis* Muell.-Arg.)
True Skin Buffalo Heads
FEATURES Meinl Free Ride Suspension System;
2 mm rounded SSR-Rims
INCLUDES Tuning key

12 FIBERCRAFT SERIES FIBERGLASS BONGOS
SIZES 7" Macho & 8 1/2" Hembra
MATERIALS Premium fiberglass
FFB400BK: True Skin Cow Heads
FFBR400BK: REMO® Black Calfskin Skynddeep® Heads
FEATURES Meinl Free Ride Suspension System;
Chrome plated hardware; 8 mm strong tuning lugs;
3 mm rounded SSR-Rims; Resonance Shaping Area
INCLUDES Accessory pouch; L-shaped tuning key; Tune Up Oil

BONGOS

1



Black, 6 1/2" & 7 1/2"
HB50BK



Ultimate Grey, 6 1/2" & 7 1/2"
HB50UG



Bright White, 6 1/2" & 7 1/2"
HB50WH



Flamingo Pink, 6 1/2" & 7 1/2"
HB50FP



Red, 6 1/2" & 7 1/2"
HB50R



Electric Coral, 6 1/2" & 7 1/2"
HB50EC



Creamsicle, 6 1/2" & 7 1/2"
HB50CS



Illuminating Yellow, 6 1/2" & 7 1/2"
HB50IY



Forest Green, 6 1/2" & 7 1/2"
HB50FG



Seafoam Green, 6 1/2" & 7 1/2"
HB50SF



Glacier Blue, 6 1/2" & 7 1/2"
HB50GB

2



Walnut Brown, 6 3/4" & 8"
HTB100WB-M

TRADITIONAL
TTR-RIM

3



Natural, 6 3/4" & 8"
HB100NT



Vintage Sunburst, 6 3/4" & 8"
HB100VSB



Wine Red Burst, 6 3/4" & 8"
HB100WRB



Vintage Wine Barrel, 6 3/4" & 8"
HB100VWB-M

1 JOURNEY SERIES HB50 BONGOS

SIZES 6 1/2" Macho & 7 1/2" Hembra

MATERIALS Molded ABS

Hand selected buffalo heads

FEATURES Black powder coated hardware;
Rounded rims for playing comfort

INCLUDES Tuning key

COLOURS **BK:** Black; **CS:** Creamsicle; **EC:** Electric Coral; **FG:** Forest Green; **FP:** Flamingo Pink; **GB:** Glacier Blue; **IY:** Illuminating Yellow; **R:** Red; **SF:** Seafoam Green; **UG:** Ultimate Grey; **WH:** Bright White

HEADLINER® SERIES WOOD BONGOS

2 3

SIZES 6 3/4" Macho & 8" Hembra

MATERIALS Siam Oak (*Hevea brasiliensis* Muell.-Arg.)
Hand selected buffalo heads

FEATURES Black powder coated hardware; 8 mm strong tuning lugs; Interior backing plates

INCLUDES Tuning key

2 HEADLINER® SERIES HTB100 WOOD BONGO

FEATURE 5 mm strong TTR-Rims

COLOUR **WB-M:** Walnut Brown, matte

3 HEADLINER® SERIES HB100 WOOD BONGOS

FEATURE 2 mm rounded rims for playing comfort

COLOURS **NT:** Natural, high gloss
VSB: Vintage Sunburst, high gloss
VWB-M: Vintage Wine Barrel, matte
WRB: Wine Red Burst, high gloss

4 BONGO & PERCUSSION PACK

CONTAINS Journey Series HB50BK Bongo; Compact Foot Tambourine; Luis Conte Live Shaker; Classic Wood Claves

5 HEADLINER® SERIES HFB100 FIBERGLASS BONGO

SIZES 6 3/4" Macho & 8" Hembra

MATERIALS Premium fiberglass

Hand selected buffalo heads

FEATURES Black powder coated hardware; 8 mm strong tuning lugs; 2.6 mm rounded rims

INCLUDES Tuning key

COLOUR **BK:** Black

6 WB200 WOOD BONGOS

SIZES 6 3/4" Macho & 8" Hembra

MATERIALS Siam Oak (*Hevea brasiliensis* Muell.-Arg.)
Hand selected buffalo heads

FEATURES Solid woodblock connection; 8 mm strong tuning lugs; 2 mm rounded SSR-Rims
WB200NT-CH: Chrome plated hardware
WB200NT-G: Gold tone hardware
WB200SNT-M: Chrome plated hardware



4

Set, 4 pcs.
BPP-1

WITH JOURNEY
SERIES HB50BK BONGO

5

Black, 6 3/4" & 8"
HFB100BK

PREMIUM FIBERGLASS

6

Natural, 6 3/4" & 8"
WB200NT-CH

CHROME PLATED
ROUNDED SSR RIM

7

NEW
REMO HEADS AVAILABLE

Wine Red, 6 3/4" & 8"
WBTR300WR

TRADITIONAL TTR-RIM

Natural, 6 3/4" & 8"
WB200NT-G

GOLD TONE
ROUNDED SSR RIM

Super Natural, 6 3/4" & 8"
WB200SNT-M

CHROME PLATED
ROUNDED SSR RIM

8

Natural, 6 3/4" & 8"
FWB200NT

Gold Amber Sunburst, 6 3/4" & 8"
FWB200GAB

9

Leopard Burl, 6 3/4" & 8"
FWB190LB

Amber Flame, 6 3/4" & 8"
FWB190AF

10

Natural, 6 3/4" & 8"
FWB190NT

Super Natural, 6 3/4" & 8"
FWB190SNT-M

Antique Tobacco Burst, 6 3/4" & 8"
FWB190ATB-M

11

NEW

Wine Red, 6 3/4" & 8"
WB200WRP-CH

INCLUDES Accessory pouch; L-shaped tuning key; Tune Up Oil
COLOURS **NT:** Natural, high gloss
SNT-M: Super Natural, matte

7 TRADITIONAL SERIES BONGO
SIZES 6 3/4" Macho & 8" Hembra
MATERIALS Siam Oak (*Hevea brasiliensis* Muell.-Arg.)
REMO® Black Calfskin Skyndee® Heads
FEATURES Solid woodblock connection; Black powder coated hardware; 8 mm strong tuning lugs; 5 mm traditional TTR-Rims
INCLUDES Accessory pouch; L-shaped tuning key; Tune Up Oil
COLOUR **WR:** Wine Red, high gloss

MARATHON® SERIES FWB WOOD BONGOS
8 9 10
SIZES 6 3/4" Macho & 8" Hembra

MATERIALS Siam Oak (*Hevea brasiliensis* Muell.-Arg.)
Hand selected buffalo heads
FEATURES Meinl Free Ride Suspension System; 8 mm strong tuning lugs
INCLUDES Accessory pouch; L-shaped tuning key; Tune Up Oil

8 MARATHON® EXCLUSIVE SERIES FWB200 WOOD BONGOS
FEATURES Chrome plated hardware; 2 mm rounded SSR-Rims
COLOURS **GAB:** Gold Amber Sunburst, high gloss
NT: Natural, high gloss

9 MARATHON® DESIGNER SERIES FWB190 WOOD BONGOS
FEATURES Unique designs; Black powder coated hardware; 2.5 mm rounded SSR-Rims
COLOURS **AF:** Amber Flame, high gloss
LB: Leopard Burl, high gloss

10 MARATHON® SERIES FWB190 WOOD BONGOS
FEATURES Black powder coated hardware; 2 mm rounded SSR-Rims
COLOURS **ATB-M:** Antique Tobacco Burst, matte
NT: Natural, high gloss
SNT-M: Super Natural, matte

11 MARATHON® EXCLUSIVE SERIES WB200 WOOD BONGO
SIZES 6 3/4" Macho & 8" Hembra
MATERIALS New Zealand Pine Wood
Hand selected buffalo heads
FEATURES Solid woodblock connection; Chrome plated hardware
INCLUDES Accessory pouch; L-shaped tuning key; Tune Up Oil
COLOUR **WR:** Wine Red, high gloss

TIMBALES



The Timbales originated in the center of the Caribbean, where life's rhythms pulsate through the atmosphere like a constant heartbeat. These drums were originally played in small, private gatherings, and they have resonant tones and sleek, attractive shells. Their influence in the music industry increased along with the boldness of their rhythms. The Timbales are still going strong today, incorporating new genres into their sound as it develops.

Meinl Timbales are as inventive and one-of-a-kind as the artists that contributed to their creation. We collaborate closely with the best timbaleros in the world on a daily basis. By doing this, these timbales continue to serve as a symbol of lively tradition and inventive music, testifying to the rich cultural legacy of the Caribbean.

SIGNATURE TIMBALES & HAND-BALE



TIMBALES

1 **NEW**

Manolito Rodríguez

Atomic Red,
14" & 15"
MR1415

2 **NEW**

Diego Camacho

Black Diamond,
14" & 15"
DC1415

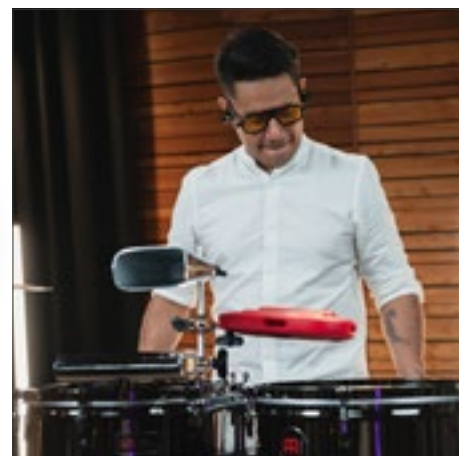

3

Amadito Valdés

Antique bronze,
14" & 15"
AV1ABR

4

Diego Galé

Solid brass,
14" & 15"
DG1415

5

Luis Conte

Solid brass,
14" & 15"
LC1BRASS

Stainless steel,
14" & 15"
LC1STS

6 **SPECIAL DESIGNED RIM**

Taku Hirano

Black powder coated steel, 13"
MHT13BK

SIGNATURE TIMBALES

1 2 3 4 5

SIZES 14" & 15"

INCLUDES L-shaped tuning key; Tune Up Oil

1 MANOLITO RODRIGUEZ SIGNATURE TIMBALES

MATERIALS Steel

Black synthetic heads

FEATURES Black nickel hardware; Easy-Tuning System

INCLUDES Professional Timbale Stand

FINISH Atomic Red

2 DIEGO CAMACHO SIGNATURE TIMBALES

MATERIALS Steel

Black synthetic heads

FEATURES Black nickel hardware; Heavy-duty-style brackets

INCLUDES Professional Timbale Stand

FINISH Black Diamond

3 AMADITO VALDÉS SIGNATURE TIMBALES

MATERIAL Steel

FEATURES Two worked-in flanges; Floatune Tuning System; Logo applied from underneath the head (CN, TH, US patent)

INCLUDES Height adjustable tilting double braced tripod stand; Adjustable cowbell holder; Accessory pouch

COLOUR Antique bronze

4 DIEGO GALÉ SIGNATURE TIMBALES

MATERIAL Solid brass

FEATURES Classic Timbales shape and look; Logo applied from underneath the head (CN, TH, US patent)

INCLUDES Professional Timbale Stand; Adjustable cowbell holder; Accessory pouch

5 LUIS CONTE SIGNATURE TIMBALES

MATERIALS **LC1BRASS:** Solid brass

LC1STS: Stainless steel

FEATURES Two worked-in flanges; Cuban style flared out bottom edge; Logo applied from underneath the head (CN, TH, US patent)

INCLUDES Height adjustable tilting double braced tripod stand; Adjustable cowbell holder; Accessory pouch

6 TAKU HIRANO SIGNATURE HAND-BALE

SIZE 13"

MATERIAL Black powder coated steel

FEATURE Logo applied from underneath the head (CN, TH, US patent)

INCLUDES L-shaped tuning key; Tune Up Oil

COLOUR **BK:** Black, high gloss

TIMBALES HEADS & TIMBALES

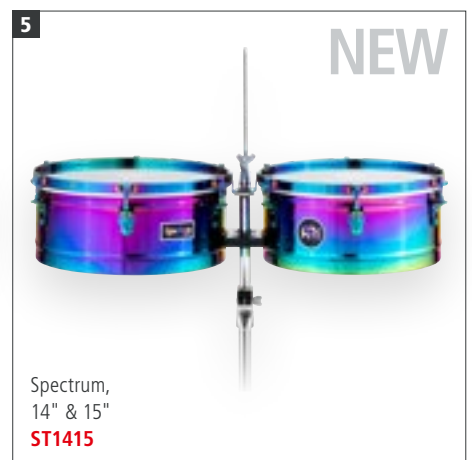
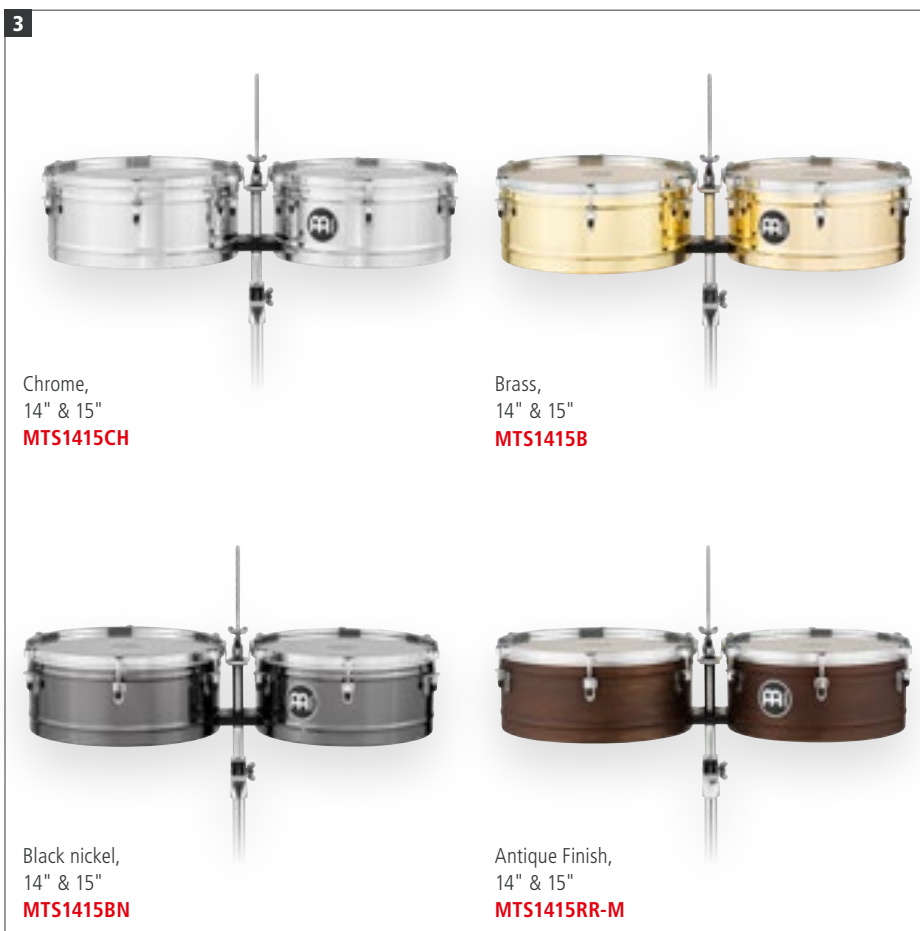
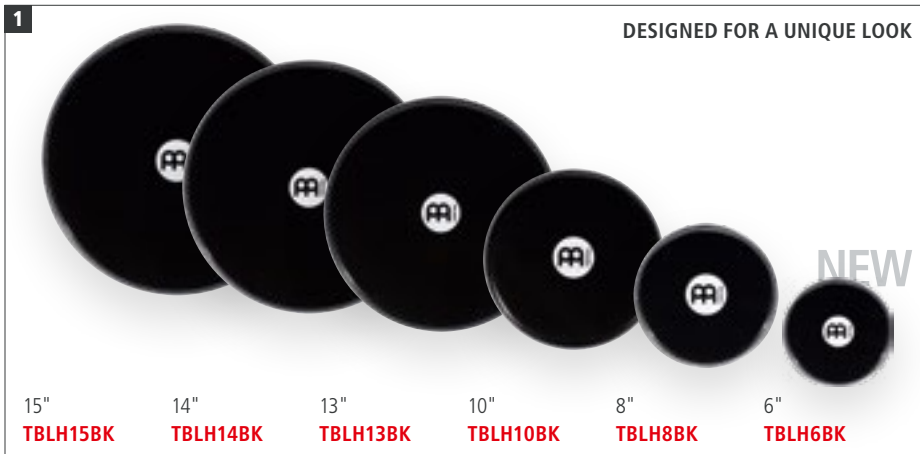

1 TIMBALES HEADS

SIZES **TBLH6BK:** 6"
TBLH8BK: 8" (Mini Timbales Head)
TBLH10BK: 10" (Mini Timbales Head)
TBLH13BK: 13"
TBLH14BK: 14"
TBLH15BK: 15"

MATERIAL Synthetic head

FEATURES Cutting and clean tone with effortless response; Extremely durable

COLOUR Black

2 HEADLINER® SERIES TIMBALES

SIZES 13" & 14"

MATERIAL Steel

FEATURES Logo applied from underneath the head (CN, TH, US patent); Two worked-in flanges

INCLUDES Height adjustable tilting double braced tripod stand; Tuning key; Wrench; Cowbell holder

FINISH Chrome

3 MARATHON® SERIES TIMBALES

SIZES 14" & 15", 6.5" deep

MATERIAL Steel

FEATURES Two worked-in flanges; Heavy-duty style brackets; Logo applied from underneath the head (CN, TH, US patent)

INCLUDES Adjustable cowbell holder; Height adjustable tilting double braced tripod stand; Accessory pouch; L-shaped tuning key; Tune Up Oil

FINISHES **B:** Brass
BN: Black nickel
CH: Chrome
RR-M: Antique Finish, matte

4 MARATHON® SERIES TURBO TIMBALES

SIZES 14" & 15", 10" deep

MATERIAL Black powder coated steel

FEATURES Three worked-in flanges; Heavy-duty style brackets; Logo applied from underneath the head (CN, TH, US patent)

INCLUDES Adjustable cowbell holder; Height adjustable tilting double braced tripod stand; Accessory pouch; L-shaped tuning key; Tune Up Oil

COLOUR **BK:** Black

5 SPECTRUM SERIES TIMBALES

SIZES 14" & 15"

MATERIALS Steel

FEATURES Black synthetic heads; Spectrum Series hardware; Easy-Tuning System

INCLUDES Professional Timbale Stand; L-shaped tuning key; Tune Up Oil

FINISH Spectrum

DRUMMER TIMBALES & COMPACT SNARE DRUMS



6

NEW

SNARE WIRES ARE ABSOLUTELY QUIET AND CHATTER-FREE IN THE "OFF" POSITION





Black powder coated steel, 6"
MDST6BK

Black powder coated steel, 8"
MDST8BK

Black powder coated steel, 10"
MDST10BK

7

NEW



Spectrum, 6"
SMDT6

8

NEW



Spectrum, 6" & 8"
SMIT68



Spectrum, 8" & 10"
SMIT810

9



Chrome, 8" & 10"
MIT810CH

Chrome, 13"
MDT13CH

10



Maple, 10"
MPCSS

11



Maple, 10"
MPJS

6 DRUMMER SNARE TIMBALES

- SIZES** **MDST6:** 6"
MDST8: 8"
MDST10: 10"
- MATERIALS** Black powder coated steel
MDST6BK: Black timbales head
- FEATURES** **MDST6BK**
Top-Tuning System; Quick snare on/off system
MDST8BK, MDST10BK
Quick snare on/off system; Chatter-free "off" position; Logo applied from underneath the head (CN, TH, US patent)
- INCLUDES** **MDST6BK:** Drum Key
MDST8BK, MDST10BK:
L-shaped tuning key; Tune Up Oil
- COLOUR** **BK:** Black

7 SPECTRUM SERIES DRUMMER SNARE TIMBALES

- SIZE** 6"
- MATERIALS** Steel
Black timbales head
- FEATURES** Top-Tuning System; Quick snare on/off system; Chrome hardware
- INCLUDES** Drum Key
- FINISH** Spectrum

8 SPECTRUM SERIES DRUMMER MINI TIMBALES

- SIZES** **SMIT68:** 6" & 8"
SMIT810: 8" & 10"
- MATERIALS** Steel
Black timbales heads
- FEATURE** Chrome hardware
- INCLUDES** L-shaped tuning key; Tune Up Oil
- FINISH** Spectrum

9 DRUMMER TIMBALE & MINI TIMBALES

- SIZES** **MDT13CH:** 13" (Drummer Timbale)
MIT810CH: 8" & 10" (Mini Timbales)
- MATERIAL** Steel
- FEATURE** Logo applied from underneath the head (CN, TH, US patent)
- INCLUDES** L-shaped tuning key; Tune Up Oil

10 COMPACT SIDE SNARE DRUM

- SIZE** 10", 3.5" deep
- MATERIAL** Maple
- COLOUR** Black

11 COMPACT JINGLE SNARE DRUM

- SIZE** 10", 4.5" deep
- MATERIALS** Maple shell
Stainless steel jingles
- COLOUR** Black

COWBELLS



The cowbell, a versatile and distinctive percussion instrument, carries a rich and fascinating history. Born as a humble bell for livestock, it transcended its origins to become a vital part of musical traditions around the world. Its true essence shines most brightly in the passionate rhythms of Latin percussion. Played with a wooden stick, the cowbell anchors the rhythm section and keeps the group in sync.

Meinl offers a wide range of cowbells in various sizes and tunings, each crafted to produce unique and expressive sounds. We collaborate closely with our artists to fulfill their every need, ensuring that every player finds the perfect rhythm and tone. Whether it's the sharp accent in a rock beat or the heartbeat of a Latin ensemble, Meinl's cowbells bring passion and precision to every performance.

SIGNATURE COWBELLS



8"
DG-RTB

5"
DG-RCCB



8"
MR-AMB



GROOVE BELL DESIGNED
WITH MIKE JOHNSTON

7 3/4"
MJ-GB

Mike Johnston



4 1/2"
AN-BB

1 DIEGO GALÉ SIGNATURE ROYAL COWBELLS

SIZES DG-RTB: 8" (Timbale Cowbell)
DG-RCCB: 5" (Cha Cha Cowbell)
MATERIAL Special steel alloy
FEATURES Designed with Diego Galé
DG-RTB: Deep pitch and dry overtones
DG-RCCB: High pitched and bright sound
FINISH Royal Gold

2 MANOLITO RODRIGUEZ SIGNATURE ANTIQUE MAMBO COWBELL

SIZE 8" (Mambo Cowbell)
MATERIAL Special steel alloy
FEATURES Designed with Manolito Rodriguez
Deep pitch and dry overtones
FINISH Antique

3 ANIKA NILLES SIGNATURE COWBELL, BEAT BELL

SIZE 4 1/2"
MATERIAL Special steel alloy
FEATURES Attaches directly to your snare
No stand required
INCLUDES Rim clamp; U-shaped rod; Drum Honey; Drum key

4 MIKE JOHNSTON SIGNATURE COWBELL, GROOVE BELL

SIZE 7 3/4"
MATERIAL Special steel alloy
FEATURE Specifically made for drum set use
INCLUDES Two magnets (one small and one large, based on Benny Greb's Magnetic Sustain Control idea)
FINISH Vintage Steel

PERCUSSION BLOCKS (SEE PAGE 36)



MPE5NG

MPE3BK

MPE4R

COWBELLS

COWBELLS

1 BLACK POWDER COATED STEEL

8" **HCO2BK**

5" **HCO4BK**

2 BLACK POWDER COATED STEEL

8 1/2" **SL850-BK**

6 3/4" **SL675-BK**

5 1/4" **SL525-BK**

4 3/4" **SL475-BK**

3 EASY MOUNTABLE

2 1/2", 3 1/2", 5"

SLTRI-BK

4 CLASSIC ROCK COWBELL

7" big mouth, low pitch **SCL70B-BK**

8 1/2" low pitch **SCL850-BK**

7" high pitch **SCL70-BK**

5 HIGH POLISHED CHROME

8" big mouth **STB80B-CH**

8" small mouth **STB80S-CH**

7 1/2" **STB750-CH**

6 1/4" **STB625-CH**

5 1/2" **STB55-CH**

4 1/2" low pitch **STB45L-CH**

HAND BRUSHED STEEL

8" big mouth **STB80B**

8" small mouth **STB80S**

6 1/4" **STB625**

5 1/2" **STB55**

4 1/2" low pitch **STB45L**

4 1/2" medium pitch **STB45M**

4 1/2" high pitch **STB45H**

COWBELLS 1 – 10

MATERIAL Special steel alloy

1 HEADLINER® SERIES COWBELLS

SIZES **HCO2BK**: 8" (Timbales Cowbell)
HCO4BK: 5" (Cha Cha Cowbell)

FEATURE Muffled sound
FINISH **BK**: Black powder coated

2 BLACK FINISH COWBELLS

SIZES **SL850-BK**: 8 1/2" (Timbales Cowbell)
SL675-BK: 6 3/4" (Medium Timbales Cowbell)
SL525-BK: 5 1/4" (Cha Cha Cowbell)
SL475-BK: 4 3/4" (Mini Cha Cha Cowbell)

FEATURE Muffled sound
FINISH **BK**: Black powder coated

3 TRIPLE BELL

SIZES 2 1/2", 3 1/2", 5"

FEATURE Muffled sound
FINISH **BK**: Black powder coated

4 STEEL CRAFT LINE COWBELLS

SIZES **SCL70B-BK**: 7" (Classic Rock Cowbell Big Mouth)
SCL850-BK: 8 1/2" (Timbalero Cowbell)
SCL70-BK: 7" (Timbalero Cowbell)

FEATURES Steel alloy controls overtones and resonance; Classic cowbell sound for any setting
FINISH **BK**: Black powder coated

5 CHROME & STEEL FINISH COWBELLS

SIZES **STB80B**: 8" (Timbales Cowbell Big Mouth)
STB80S: 8" (Timbales Cowbell Small Mouth)
STB750: 7 1/2" (Salsa Timbales Cowbell)
STB625: 6 1/4" (Medium Timbales Cowbell)
STB55: 5 1/2" (Cha Cha Cowbell)
STB45L: 4 1/2" (Low Cha Cha Cowbell)
STB45M: 4 1/2" (Medium Cha Cha Cowbell)
STB45H: 4 1/2" (High Cha Cha Cowbell)

FEATURE Tonally matched
FINISHES Hand brushed steel
CH: High polished chrome



6 **HAND BRUSHED GOLD**  
 8" big mouth **STB80BHH-G** 6 1/4" **STB625HH-G**

HAND BRUSHED STEEL  
 8" big mouth **STB80BHH-S** 6 1/4" **STB625HH-S**

HAND BRUSHED COPPER  
 8" big mouth **STB80BHH-C** 6 1/4" **STB625HH-C**

7 **NEW**  **NEW** 
 8 1/2" **SHBC** 7 1/2" **SHBG**

8 **BLACK POWDER COATED STEEL** 
 8" **BCOB**

9 **SPECIAL STEEL ALLOY**  
 8 1/4" **STB815H** 7 3/4" **STB785H** 6 1/2" **STB65H**

10 **COMFORTABLE HOLDER**  
 6 1/4" **STB625HA-CB** 4 1/2" **STB45HA-CB**

11 **PALO COWBELL BEATER**
 (SEE PAGE 125)

COW5

11 **Magnetic Sustain Control**
MCT

BASED ON BENNY GREB'S IDEA

12 **DRUM HONEY SLAB**
MDHS

13 **A DROP OF HONEY MAKES YOUR DRUMS AND CYMBALS SOUND SWEET**

Drum Honey MDH **Drum Honey Assortment MDHA**

14 **COWBELL CUSHIONS**
MPCC-M **MPCC-L**

6 HAMMERED COWBELLS
SIZES **STB80BHH:** 8" (Timbales Cowbell Big Mouth)
STB625HH: 6 1/4" (Medium Timbales Cowbell)
FEATURE Hammered
FINISHES **C:** Hand brushed copper
G: Hand brushed gold
S: Hand brushed steel

7 SALSA HANDHELD COWBELLS
SIZES **SHBC:** 8 1/2"
SHBG: 7 1/2"
TUNING **SHBC:** C
SHBG: G

8 BONGO COWBELL
SIZE 8" (Medium Handheld Cowbell)
FEATURES Muffled sound; For low volume playing
FINISH Black powder coated

9 HAND COWBELLS
SIZES **STB815H:** 8 1/4" (High Handheld Cowbell)
STB785H: 7 3/4" (Low Handheld Cowbell)
STB65H: 6 1/2" (Mini Handheld Cowbell)
FINISH Hand brushed steel

10 HANDHELD COWBELLS
SIZES **STB625HA-CB:** 6 1/4"
STB45HA-CB: 4 1/2"
FEATURE Comfortable holder
FINISH Hand brushed steel

11 MAGNETIC SUSTAIN CONTROL
CONTAINS 2 x Light dampening magnets (16 x 4 mm)
 2 x Heavy dampening magnets (16 x 9 mm)
FEATURE Easily control the sustain and dampen the tone of your cymbals or cowbells
INCLUDES Storage container

12 DRUM HONEY SLAB
SIZE 3.54" x 2.36" x 0.31"
FEATURES Extra thick rectangular dampening gel pad; Creates a super meaty drum tone

13 DRUM HONEY
CONTAINS **MDH:** 1 pack of Drum Honey (6 pcs.)
MDHA: 12-piece Drum Honey Assortment (6 x small, 4 x medium, 2 x large)
FEATURES Transforms your drum sound into a warm and sweet tone with no effort; The gels can be removed and reused as needed; Washable and non-toxic

14 COWBELL CUSHIONS
SIZES **MPCC-M:** Medium (32 grams)
MPCC-L: Large (70 grams)
FEATURES Instantly turn your cowbell sound into a retro, super-dry effect; No adhesive material required



LATIN INSTRUMENTS



Discover the vibrant world of Latin hand percussion instruments, where rhythm and culture come together. Our collection features a variety of traditional instruments like maracas, güiros, claves, cabasas and many more, perfect for adding authentic Latin flavor to your music. Whether you're a professional musician or a hobbyist, these instruments bring warmth, energy, and versatility to any performance. Explore the craftsmanship and history behind each piece, and elevate your sound with the rich percussive beats of Latin America.

GÜIROS & CLAVES



1 TURBO GÜIRO

MATERIAL High strength plastic
FEATURES Three striking surfaces; Rubber ringed grip holes
INCLUDES Synthetic scraper

2 FIBERGLASS GÜIROS

MATERIAL Premium fiberglass
FEATURES Three striking surfaces; Padded grip holes
INCLUDES **GU7BK**: Synthetic scraper
GU7BR: Wooden scraper
COLOURS **BK**: Black
BR: Brown

3 WOOD GÜIRO

MATERIAL Wood
FEATURE Grip holes
INCLUDES Wooden scraper
COLOUR **AM**: Amber

4 LATIN RHYTHM CLAVES

SIZE 8" & 7" long
MATERIAL Select Hardwood
FEATURES For foundational latin rhythms; Solid body construction; Traditional look

5 WOOD CLAVES, CLASSIC

MATERIALS **HW**: Hardwood
RW: Select Hardwood
FEATURE Solid body

6 WOOD CLAVES, AFRICAN

MATERIALS **HW**: Hardwood
RW: Select Hardwood
FEATURES **CL2**: Solid body
CL3: Hollowed out body

7 WOOD CLAVES, TRADITIONAL

SIZE 8" long and 1" diameter
MATERIAL **IW**: Indian Walnut
FEATURE Classic pitch and clear, piercing attack

8 CLAVES DE LUXE

SIZE 6 3/4" long
MATERIAL Dense hardwood
FEATURES Cutting sound; Convenient carrying

MARACAS

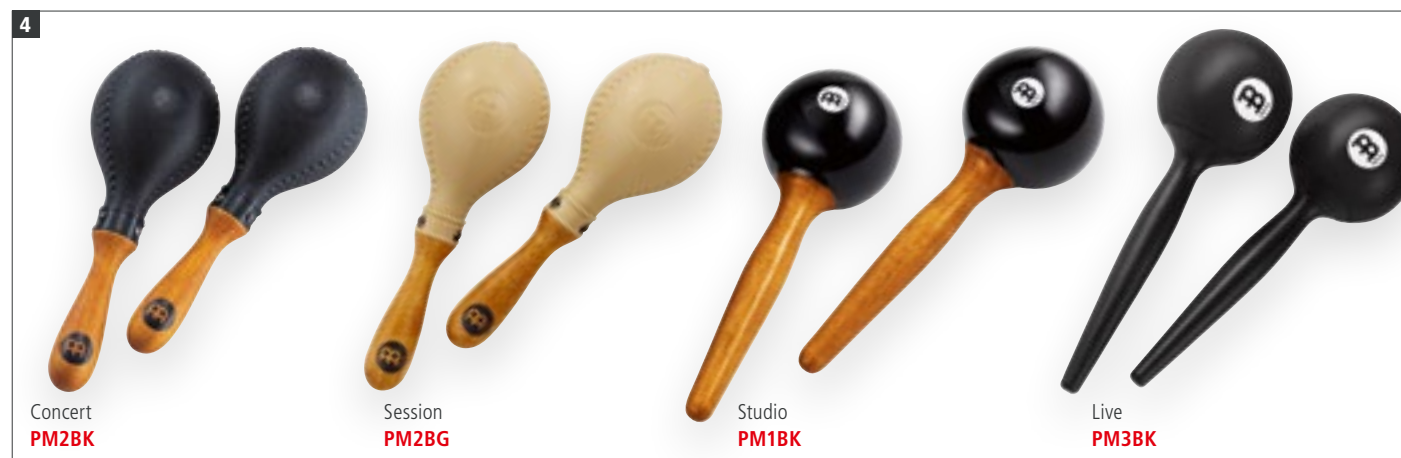

1 RAWHIDE MARACAS

SIZES **MSM2:** Mini
MSM3: Traditional
MSM4: Jumbo

MATERIALS Natural rawhide and wooden handle

FEATURES Entirely made by hand
Offers a wide sonic range
Durable construction

DESIGNS **CO:** Colombia flag
CU: Cuba flag
MX: Mexico flag

2 WOOD MARACAS

MATERIAL Wood

FEATURES Produces a traditional warm and rich sound
Available in both round and oval models

3 PLASTIC EGG MARACAS

SIZE 6"

MATERIAL Synthetic

FEATURE Ergonomically shaped handle

4 CONCERT, SESSION, STUDIO & LIVE MARACAS

MATERIAL Synthetic heads

FEATURE Ergonomically shaped handle

COLOURS **BG:** Beige
BK: Black



LATIN INSTRUMENTS



Set, 5 pcs.
TMSTB



High pitch
MPE5NG

Medium pitch
MPE3BK

Low pitch
MPE4R



Set, 5 pcs.
TMWTB



TMWB-XS

TMWB-S

TMWB-L



MWBHC



Large
PMWB1-L

Medium
PMWB1-M



Medium
MWB1BK

Large
MWB2BK

1 SYNTHETIC TEMPLE BLOCK SET

MATERIAL PE
FEATURES 5-piece set of durable synthetic percussion blocks; Varying pitch from high (smallest block) to low (largest block); Metal frame with adjustable thumb screw mount
INCLUDES Mounting Clamp; Beater
COLOUR Black

2 PERCUSSION BLOCKS

MATERIAL PE
FEATURES Ultra-durable plastic
MPE5NG: High pitched sound
MPE3BK: Medium pitched sound
MPE4R: Low pitched sound
INCLUDES Mounting Clamp
COLOURS **BK**: Black
NG: Neon Green
R: Red

3 WOOD TEMPLE BLOCK SET

MATERIAL Baltic Birch (*Betula pendula*)
FEATURES 5-piece tonally matched wood temple block set; 100% Baltic birch construction for natural wood tone; Rear mount fits any standard drum hardware; Tuning from low to high: D5, F5, A5, C6, D6
INCLUDES Two soft rubber head mallets

4 WOOD TEMPLE BLOCKS

MATERIAL Baltic Birch (*Betula pendula*)
TUNING **TMWB-XS**: D6
TMWB-S: C6
TMWB-L: F5
FEATURES Natural wood tone; Fits a variety of musical situations
INCLUDES Wood block holder

5 WOOD BLOCK HAND CLAP

MATERIAL Baltic Birch (*Betula pendula*)

FEATURES Combination wood block and hand clap effect; Padded surface to play with drumsticks

6 PROFESSIONAL WOOD BLOCKS

SIZES **M**: Medium
L: Large
MATERIALS Select Hardwood top
Siam Oak body
(*Hevea brasiliensis* Muell.-Arg.)
FEATURE Well defined fundamental sound
INCLUDES Wooden beater

7 WOOD BLOCKS

SIZES **MWB1BK**: Medium
MWB2BK: Large
MATERIAL Siam Oak (*Hevea brasiliensis* Muell.-Arg.)
FEATURE Rounded playing surface
INCLUDES Wooden beater
COLOUR **BK**: Black, matte

8 PORTS FOR MORE VOLUME (PATENTED)

X-Small
PCA5BK-XS

Small
CA5BK-S

Medium
CA5BK

Large
CA5BK-L

9 ADJUSTABLE NET FOR VARIOUS TENSIONS AND SOUND OPTIONS

CA7BR

10 NEARLY UNBREAKABLE

SH-R **SHR-BR** **SHK**

11

RO3BK

12 TRUE SKIN BUFFALO HEADS

11"
MTA1SNT-M

13 HEAVY-DUTY STAND CAN BE TILTED

8" & 9"
HCG89NT

14

X-Small
MGU4

Small
MGU3

Large
MGU1

COMES WITH SCRAPER

15

MGU51

8" & 9"
HCG89NT

8 TURBO CABASAS (PATENTED)
SIZES **PCA5BK-XS**: X-Small; **CA5BK-S**: Small
CA5BK: Medium; **CA5BK-L**: Large
MATERIALS Steel chain and stainless steel cylinder
CA: Wooden handle with padded soft grip
PCA: Synthetic grip
FEATURE 5 sound ports on each side for more volume (CN, US patent)
COLOUR **BK**: Black

9 CABASA, FIBERGLASS
MATERIAL Premium fiberglass
FEATURES Adjustable net for various tensions and sound options; Equals a traditional gourd calabash
COLOUR **BR**: Brown

10 SHEKERES
SIZES **SH-R, SHR-BR**: Medium
SHK: Traditional

MATERIALS **SH-R, SHR-BR**: Premium fiberglass
SHK: Gourd
COLOURS **BR**: Brown
R: Red

11 THE ROAR
MATERIAL Wood
FEATURE Rattling sustain

12 TAMBORA
SIZE 11"
MATERIALS Siam Oak (*Hevea brasiliensis* Muell.-Arg.)
True Skin Buffalo Heads
FEATURE Black powder coated hardware
INCLUDES Nylon strap; Wooden beaters; Tuning key
COLOUR **SNT-M**: Super Natural
FINISH Matte

13 WOOD CONGUITAS
SIZES 8" & 9"

MATERIALS Siam Oak (*Hevea brasiliensis* Muell.-Arg.)
Hand selected buffalo heads
INCLUDES Height adjustable tilting double braced tripod stand; Tuning key; Wrench
COLOUR **NT**: Natural
FINISH High gloss

14 MERENGUE GÜIRAS
SIZES **MGU4**: X-Small; **MGU3**: Small;
MGU1: Large
MATERIAL Brushed steel
FEATURE One-piece metal grip with welded flanges
INCLUDES ABS scraper MG52

15 MERENGUE GÜIRA SHAKER
MATERIAL Brushed steel
FEATURE Filling inside to produce a cutting shaker effect
INCLUDES ABS scraper MG52

CAJONS



The cajón is a versatile and dynamic percussion instrument, rooted in Afro-Peruvian traditions and widely used across various music genres. Its simple wooden box design delivers deep bass tones and sharp, snappy highs, making it perfect for both acoustic and amplified performances. Whether you're playing flamenco, Latin, or contemporary music, the cajón offers a rich rhythmic foundation. Ideal for drummers and percussionists alike, its portability and range of sounds make it an essential addition to any setup. Explore the rhythmic possibilities of the cajón and bring a new dimension to your music.



ARTISAN EDITION CAJONS

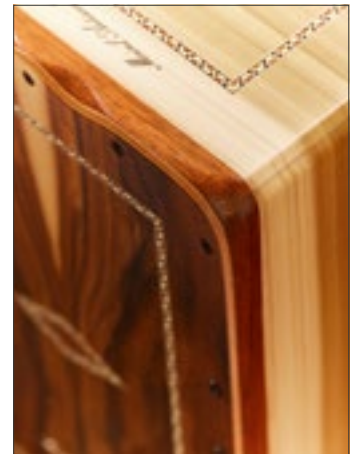
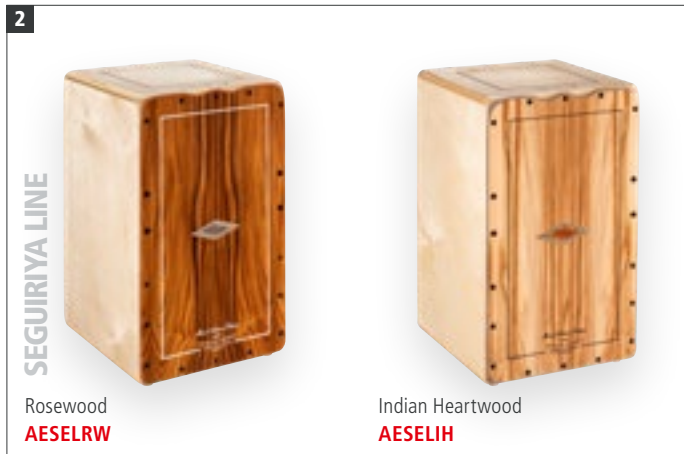

José Hernández Díaz also known as 'Pepote' – was born in Huelva (Spain) in November 1976. He inherited his passion for wood from his father and grandfather, both of whom were aficionados of woodworking and model aeroplanes.

He first came across the Cajon at the age of 13 while watching a Paco de Lucía concert on television. Inspired to make his own, he soon started receiving commissions from friends and acquaintances when they realised that the Cajon was virtually impossible to get hold of in Spain. Pepote began taking these instruments to local shops in his city when he was just 15 years old. This marked the start of his woodwork training, where he focused on the production of musical instruments by studying techniques for making ancient musical instruments and guitars while also completing his studies in industrial furniture design.

Since then, he has been continually developing the instrument and relentlessly perfecting his craft. He came up with an aesthetic based on comfort, tried and tested more than 30 different kinds of wood for construction, created a special unbreakable string for the Cajon and tried 20 different kinds of varnish for the finish. The list goes on. Everything he does revolves around getting the best possible sound out of the instrument and providing the ultimate peace of mind for the percussionist.



ARTISAN EDITION CAJONS

FEATURES Rounded corners and thumb notches for optimal playing comfort and sound
Ergonomically rounded frontplate with convex contact
Specially formulated soft rubber feet
Martinete, Seguriya, Cantina Line: Extra thick wooden sound port ring for compression
Two tuning screws to adjust the tension for each set of strings
Pop filter on soundhole
Seguriya, Cantina, Minera, Bulería, Soleá, Tango Line: Elegant heat-branding on resonating body

1 MARTINETE LINE

SIZE 11 1/2" W x 19" H x 12 3/4" D
MATERIALS Resonating body: Solid Wood (15 mm)
Tulip Poplar (*Liriodendron tulipifera*)
Frontplate: Brazilian Ironwood (*Phoebe porosa*) with Ukola Woodframe
FEATURES Two sets of 10 adjustable strings (Separately per side)
6 specially formulated soft rubber feet
INCLUDES Tuning key

2 SEGUIRIYA LINE

SIZE 11 1/4" W x 19" H x 11 3/4" D
MATERIALS Resonating body: 9-Ply (12 mm)
Baltic Birch (*Betula Pendula*)
AESELIH Frontplate: Indian Heartwood
AESELRW Frontplate: Rosewood
FEATURE Two sets of 8 adjustable strings (Separately per side)
INCLUDES Tuning key

3 CANTINA LINE

SIZE **AECLBE, AECLLI** 11 1/4" W x 19" H x 11 3/4" D
AECLWN 12 1/2" W x 18 1/2" H x 12 1/2" D
MATERIALS Resonating body: 9-Ply (12 mm)
Baltic Birch (*Betula Pendula*)
AECLBE Frontplate: Brown Eucalyptus
AECLLI Frontplate: Limba
AECLWN Frontplate: Walnut
FEATURES **AECLBE, AECLLI** Forward projecting sound port
Two sets of 6 pre-tuned strings
AECLWN Two sets of 8 adjustable strings from the top (Separately per side)
Decorative wood inlay
INCLUDES Tuning key

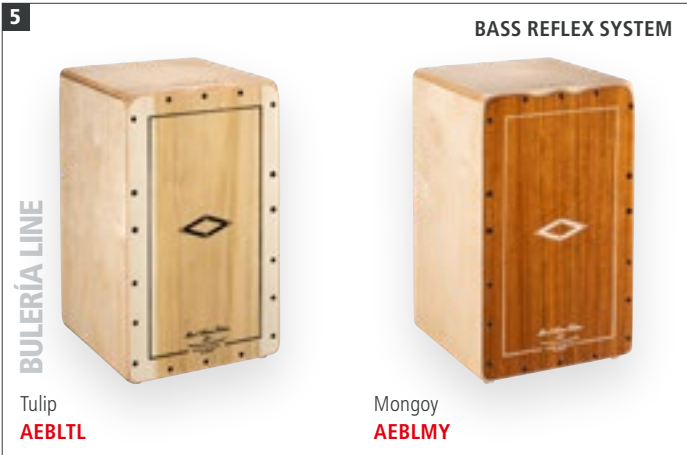

4 MINERA LINE
SIZE 11 1/4" W x 19" H x 11 3/4" D
MATERIALS Resonating body: 9-Ply (12 mm) Baltic Birch (*Betula Pendula*)
AEMILLI Frontplate: Limba
AEMILBE Frontplate: Brown Eucalyptus
FEATURE Two sets of 4 pre-tuned strings
INCLUDES Tuning key

5 BULERÍA LINE
SIZE 11 1/4" W x 19" H x 11 3/4" D
MATERIALS Resonating body: 9-Ply (12 mm) Baltic Birch (*Betula Pendula*)
AEBLMY Frontplate: Mongoy
AEBLTL Frontplate: Tulip

FEATURES Two sets of 5 adjustable strings (Separately per side)
 Tuning screw to adjust string tension
 Pop filter on soundhole
 Bass reflex system
INCLUDES Tuning key

6 SOLEÁ LINE
SIZE 11 1/4" W x 19" H x 11 3/4" D
MATERIALS Resonating body: 9-Ply (12 mm) Baltic Birch (*Betula Pendula*)
 Frontplate: Selected wood
FEATURES Two sets of 5 pre-tuned strings
 Bass reflex system
FINISHES **AESLEB** Frontplate: Espresso Burst
AESLEYB Frontplate: Ebony Burst
AESLRB Frontplate: Dark Red Burst

7 TANGO LINE
SIZE 11 1/4" W x 19" H x 11 3/4" D
MATERIALS Resonating body: 7-Ply (9 mm) Baltic Birch (*Betula Pendula*)
AETLBE Frontplate: Brown Eucalyptus
AETLBF Frontplate: Selected wood
AETLGE Frontplate: Grey Eucalyptus
AETLLE Frontplate: Light Eucalyptus
AETLLI Frontplate: Limba
AETLRF Frontplate: Selected wood
AETLSBK Frontplate: Selected wood
FEATURE FINISHES Two sets of 3 pre-tuned strings
AETLBF Frontplate: Blue Fade
AETLRF Frontplate: Red Fade
AETLSBK Frontplate: Satin Black

WOODCRAFT & HEADLINER® CAJONS



WOODCRAFT CAJONS **1** **2**

SIZE 11 3/4" W x 19 3/4" H x 12" D
FEATURES Custom micro-coiled steel cajon strings; Baltic birch construction; Rounded corners for added comfort; Rubber feet and rear sound port

1 WOODCRAFT PROFESSIONAL CAJONS

MATERIALS Resonating body: 9-Ply (12 mm) Baltic Birch (*Betula pendula*)
WCP100MB Frontplate: Makah-Burl
WCP100MH Frontplate: Mahogany

2 WOODCRAFT CAJONS

MATERIALS Resonating body: 7-Ply (9 mm) Baltic Birch (*Betula pendula*)
WC100B Frontplate: Baltic Birch (*Betula pendula*)
WC100EB Frontplate: Espresso Burst

3 HEADLINER® SERIES STRING CAJONS

SIZES **HCAJ1:** 11 3/4" W x 18" H x 12 1/4" D
HCAJ3: 11 3/4" W x 19 3/4" H x 12" D

MATERIALS **HCAJ1AWA, HCAJ3AWA**
 Resonating body: Eco-friendly medium density fiberboard
 Frontplate: Stained American White Ash (*Fraxinus Americana* L.)

HCAJ1NT
 Resonating body: Baltic Birch (*Betula pendula*)
 Frontplate: Baltic Birch (*Betula pendula*)

HCAJ3LJ
 Resonating body: Eco-friendly medium density fiberboard
 Frontplate: Baltic Birch (*Betula pendula*)

FEATURES Adjustable top corners; Adjustable sizzle effect; Internal fixed cajon strings; Wide sound options
HCAJ1: Anti-slip sitting surface

INCLUDES Hex key
FINISH **AWA, NT:** Matte
LJ: Lumberjack

4 HEADLINER® SERIES SNARE CAJONS

SIZE 11 3/4" W x 18" H x 11 3/4" D
MATERIALS Resonating body: Eco-friendly medium density fiberboard
MA Frontplate: Maple
CBF, LPF, PBF, SAF, TRF Frontplate: American White Ash (*Fraxinus Americana* L.)

FEATURES Dual internal fixed snare wires; Adjustable top corner; Wide sound options
FINISHES **CBF** Frontplate: Charcoal Black Fade
LPF Frontplate: Lilac Purple Fade
MA Frontplate: Natural
PBF Frontplate: Pacific Blue Fade
SAF Frontplate: Sonoran Amber Fade
TRF Frontplate: Tango Red Fade

SNARECRAFT CAJONS



5 FOOT ACTIVATED SNARE SWITCH SNARE SWITCH KNOB

American White Ash Walnut
SCP100AWA **SCP100WN**

6

Almond Birch Almond Birch Baltic Birch Baltic Birch
SC80AB **SC100AB** **SC80AB-B** **SC100AB-B**

Baltic Birch Baltic Birch Burl Wood Burl Wood Heart Ash Heart Ash
SC80B **SC100B** **SC80BW** **SC100BW** **SC80HA** **SC100HA**

NEW **NEW** **NEW** **NEW**

Blue Burst Brown Burst Green Burst Red Burst
SCP100BLB **SCP100BRB** **SC100GRB** **SC100RDB**

5 SNARECRAFT PROFESSIONAL CAJONS

SIZE 11 3/4" W x 19 3/4" H x 12" D
MATERIALS Resonating body: 9-Ply (12 mm) Baltic Birch (*Betula pendula*)
SCP100AWA
 Frontplate: American White Ash (*Fraxinus Americana* L.)
SCP100WN
 Frontplate: Walnut
FEATURES Adjustable snare for both Flamenco and Peruvian styles; Baltic birch construction; Rounded corners for added comfort; Rubber feet and rear sound port
SCP100AWA
 Equipped with a foot activated snare switch
SCP100WN
 Equipped with a snare switch knob on the side of the cajon

6 SNARECRAFT CAJONS

SIZES **SC80:** 11 3/4" W x 18" H x 11 3/4" D
SC100: 11 3/4" W x 19 3/4" H x 11 3/4" D
MATERIALS **SC80AB, SC100AB**
 Resonating body: 7-Ply (9 mm) Almond Birch (*Betula pendula*)
 Frontplate: Almond Birch (*Betula pendula*)
SC80AB-B, SC100AB-B
 Resonating body: 7-Ply (9 mm) Almond Birch (*Betula pendula*)
 Frontplate: Baltic Birch (*Betula pendula*)
SC80B, SC100B, SC100BLB, SC100BRB, SC100GRB, SC100RDB
 Resonating body: 7-Ply (9 mm) Baltic Birch (*Betula pendula*)
 Frontplate: Baltic Birch (*Betula pendula*)
SC80BW, SC100BW
 Resonating body: 7-Ply (9 mm) Baltic Birch (*Betula pendula*)
 Frontplate: Burl Wood

SC80HA, SC100HA

Resonating body: 7-Ply (9 mm) Baltic Birch (*Betula pendula*)
 Frontplate: Heart Ash
FEATURES Dual internal fixed snare wires; Baltic birch construction; Rounded corners for added comfort; Rubber feet and rear sound port
FINISHES **BLB** Frontplate: Blue Burst
BRB Frontplate: Brown Burst
GRB Frontplate: Green Burst
RDB Frontplate: Red Burst

CAJONS

1

Almond Birch
JC50AB

Baltic Birch
JC50AB-B

Baltic Birch
JC50B

Burl Wood
JC50BW

Heart Ash
JC50HA

2

Makah-Burl, matte
TOPCAJ1MB

Walnut, matte
TOPCAJ2WN

3

CONTRASTING PLAYING SURFACES ON OPPOSITE SIDES

Baltic Birch, matte
HTOPCAJ3NT

4

FORWARD FACING SOUND PORTS

TTOPCAJ1

5

BACK

SOUND PORT FOR CLEAR PROJECTION

Black, matte
TCAJ1BK

6

INTERNAL SNARE WIRES

Natural/Ebony Black, matte
BCA2NT/EBK-M

DIFFERENT SIZED CHAMBERS ENABLE AN AUTHENTIC BONGO EFFECT

Super Natural, matte
BCA1SNT-M

7

TWO SOUND OPTIONS

TMBX

<p>1 JAM CAJONS</p> <p>SIZE 10 1/2" W x 15" H x 10 1/4" D</p> <p>MATERIALS JC50AB Resonating body: 7-Ply (9 mm) Baltic Birch (<i>Betula pendula</i>) Frontplate: Almond Birch (<i>Betula pendula</i>) JC50AB-B Resonating body: 7-Ply (9 mm) Almond Birch (<i>Betula pendula</i>) Frontplate: Baltic Birch (<i>Betula pendula</i>) JC50B Resonating body: 7-Ply (9 mm) Baltic Birch (<i>Betula pendula</i>) Frontplate: Baltic Birch (<i>Betula pendula</i>) JC50BW Resonating body: 7-Ply (9 mm) Baltic Birch (<i>Betula pendula</i>) Frontplate: Burl Wood JC50HA Resonating body: 7-Ply (9 mm) Baltic Birch (<i>Betula pendula</i>) Frontplate: Heart Ash</p> <p>FEATURES Compact size; Baltic birch construction; Dual internal fixed snare wires; Rubber feet and rear sound port</p>	<p>2 SLAPTAP CAJONS (PATENTED)</p> <p>SIZES TOPCAJ1MB 14 1/2" W x 8 3/4" H x 5 3/4" D TOPCAJ2WN (Turbo Slaptop) 14 1/2" W x 10" H x 5 3/4" D</p> <p>MATERIALS TOPCAJ1MB Resonating body: Eco-friendly medium density fiberboard; Playing surface: Makah-Burl TOPCAJ2WN (Turbo Slaptop) Resonating body: Eco-friendly medium density fiberboard; Playing surface: Walnut (<i>Juglans regia</i> L.)</p> <p>FEATURES Comfortable upright playing style; Forward facing sound ports; Dual internal fixed snare wires; Deep bass and cutting slap tones TOPCAJ2WN (Turbo Slaptop) Snares on both sides</p>	<p>3 HYBRID SLAPTAP CAJON</p> <p>SIZE 14 1/2" W x 10" H x 5 3/4" D</p> <p>MATERIAL Baltic Birch (<i>Betula pendula</i>)</p> <p>FEATURES Comfortable and unique X-design; Forward sound projection; Dual internal fixed snare wires for a snare cajon sound on one side; Bongo cajon sound on the opposite side</p> <p>4 TRAVEL SLAPTAP CAJON</p> <p>SIZE 18 3/4" W x 2 3/4" H x 9 1/2" D</p> <p>MATERIALS Resonating body: Eco-friendly medium density fiberboard; Playing surface: Maple</p> <p>FEATURES Comfortable upright playing style; Forward facing sound ports; Dual internal fixed snare wires; Crisp snare cajon sound</p> <p>5 TRAVEL CAJON</p> <p>SIZE 11 3/4"</p> <p>MATERIAL Siam Oak (<i>Hevea brasiliensis</i> Muell.-Arg.)</p> <p>FEATURES Internal snare wires; Compact design</p>
---	--	---



caiXoN
VR-CAIX

caiXoNet
VR-CAIXN

Set, 2 pcs.
VR-CAIX/CAIXN



STACKABLE FOR EASY STORAGE AND TRANSPORTATION



Makah-Burl, matte
SUBCAJ6MB-M

VERTICAL FORWARD FACING SOUND PORTS



American White Ash, matte
SUBCAJ1AWA

SUPER LOW FREQUENCY



Walnut, matte
SUBCAJ5WN

JUMBO BASS SUBWOOFER CAJON

6 BONGO CAJONS

SIZE 15 3/4" W x 6 3/4" H x 7 1/4" D
MATERIAL Siam Oak (*Hevea brasiliensis* Muell.-Arg.)
FEATURES High and low pitch playing surface; Compact size and light weight
BCA2: Dual internal fixed snare wires

7 BOXITO

SIZE 11" W x 8 1/2" H x 5 3/4" D
MATERIALS Resonating body: Baltic Birch (*Betula pendula*); Playing surface: Baltic Birch (*Betula pendula*), Exotic Zebrano
FEATURES Dual playing surfaces bongo/snare; Internal fixed snare wires; Natural wood tone

8 CAIXON & CAIXONET

SIZES **VR-CAIX** (caiXoN) 11 1/2" W x 26 1/4" H x 12" D
VR-CAIXN (caiXoNet) 10 1/2" W x 26 1/4" H x 9 1/2" D
MATERIALS Resonating body: Baltic Birch (*Betula pendula*); Playing surface: Striped Onyx
FEATURES Internal snare wires for cutting snare slaps; Perfect for seated players; Forward facing sound port
VR-CAIX: Deep bass tones
VR-CAIXN: Higher tones
VR-CAIX/CAIXN: Includes large caiXoN and smaller caiXoNet; Stackable for easy storage and transportation

9 VERTICAL SUBWOOFER CAJON

SIZE 15 1/2" W x 19 1/4" H x 11 3/4" D
MATERIALS Resonating body: Eco-friendly medium density fiberboard; Frontplate: Makah-Burl
FEATURE Dual internal fixed snare wires and bass reflex channel

10 SUBWOOFER CAJONS

SIZES **SUBCAJ1AWA** 11 3/4" W x 19 3/4" H x 12 1/4" D
SUBCAJ5WN 13 1/2" W x 19 3/4" H x 13 3/4" D
MATERIALS Resonating body: Eco-friendly medium density fiberboard
SUBCAJ1AWA Frontplate: American White Ash (*Fraxinus Americana* L.)
SUBCAJ5WN Frontplate: Walnut (*Juglans regia* L.)
FEATURES Forward projecting sound port; Dual internal fixed snare wires

PICKUP CAJONS

1 **PIEZO PICKUP WITH VOLUME AND TONE CONTROL**



SOLEÁ LINE

Dark Olive Burst
PAESLDOB

2



Baltic Birch
PWC100B

Makah-Burl
PWCP100MB

3



Baltic Birch
PSC100NT

Baltic Birch
PSC100B

4



Baltic Birch
PJC50B

5



Baltic Birch
PSUBCAJ6B

6 **INDIVIDUAL SNARE AND BASS CONTROL**



Walnut
PTOPCAJ2WN

Mahogany
PTOPCAJ4MH-M

1 ARTISAN EDITION PICKUP CAJON, SOLEÁ LINE

SIZE 11 1/4" W x 19" H x 11 3/4" D
MATERIALS Resonating body: 9-Ply (12 mm) Baltic Birch (*Betula Pendula*)
 Frontplate: Dark Olive Burst
FEATURES Piezo pickup with volume and tone control; Two sets of 5 pre-tuned strings; Rounded corners and thumb notches for optimal playing comfort and sound; Ergonomically rounded frontplate with convex contact; Bass reflex system

2 PICKUP WOODCRAFT SERIES CAJONS

SIZE **PWCP100MB** (Woodcraft Professional) 11 3/4" W x 19 3/4" H x 12" D
PWC100B (Woodcraft) 11 3/4" W x 19 3/4" H x 12" D
MATERIALS Resonating body: Baltic Birch (*Betula pendula*)

FEATURES **PWCP100MB** (Woodcraft Professional) Frontplate: Makah-Burl
PWC100B (Woodcraft) Frontplate: Baltic Birch (*Betula pendula*)
FEATURES Three Piezo pickups for snare and bass sounds; Rubber feet and rear sound port
COLOURS **PWCP100MB** Resonating body: Black
PWC100B Resonating body: Natural

3 PICKUP SNARECRAFT SERIES CAJONS

SIZE 11 3/4" W x 19 3/4" H x 11 3/4" D
MATERIALS Resonating body: Baltic Birch (*Betula pendula*)
 Frontplate: Baltic Birch (*Betula pendula*)
FEATURES Three Piezo pickups for snare and bass sounds; Baltic birch construction
COLOURS **PSC100B** Resonating body: Black

PSC100NT
 Resonating body: Natural

4 PICKUP JAM CAJON

SIZE 10 1/2" W x 15" H x 10" D
MATERIALS Resonating body: Baltic Birch (*Betula pendula*)
 Frontplate: Baltic Birch (*Betula pendula*)
FEATURES Compact size; Dual internal fixed snare wires; Piezo pickup with volume control
COLOUR Natural

5 PICKUP VERTICAL SUBWOOFER CAJON

SIZE 15 1/2" W x 19 1/4" H x 11 3/4" D
MATERIALS Resonating body: Eco-friendly medium density fiberboard
 Frontplate: Baltic Birch (*Betula pendula*)
FEATURES Vertical forward-facing sound ports; Piezo pickup with volume and tone control; Dual internal fixed snare wires

7





Birch Wood
MPDC1

DIGITAL CAJON FOR EXPANDED SOUND OPTIONS AND SILENT PRACTICE

DIGITAL CAJON SOUNDS

- 0 - MEINL Subwoofer Cajon + MEINL Tambourine
- 1 - MEINL Snarecraft Cajon + MEINL Splash Cymbal
- 2 - MEINL Cantina Line Artisan Cajon + MEINL Closed Hihat Cymbal
- 3 - MEINL Slaptop Cajon + Hand Clap
- 4 - MEINL Woodcraft Cajon + MEINL Crash Cymbal
- 5 - Rock Drum Kit + MEINL Closed Hihat Cymbal
- 6 - Drum Machine + MEINL Ride Cymbal
- 7 - MEINL Marathon® Classic Congas
- 8 - MEINL Fibercraft Bongos + MEINL Percussion Block
- 9 - MEINL Diego Galé Signature Timbales + MEINL Steel Craft Cowbell

9



Baltic Birch
MMCS

CAJON MICROPHONE STAND (SEE PAGE 116)

CMS

8

TWO 4.5" 20-WATT SPEAKERS



Baltic Birch
MPSCAJ

PRACTICE TO MUSIC OR INCORPORATE LOOPS IN YOUR PERFORMANCES

10



MIC-PERC

11



PA-CAJ

MICROPHONE CAJON CLAMP
(SEE PAGE 123)



MPMCC

6 PICKUP SLAPTOP CAJONS (PATENTED)

SIZES **PTOPCAJ2WN** (Turbo Slaptop)
14 1/2" W x 10" H x 5 3/4" D
PTOPCAJ4MH-M
15 1/2" W x 8 1/2" H x 7 1/2" D

MATERIALS **PTOPCAJ2WN** (Turbo Slaptop)
Resonating body: Baltic Birch (*Betula pendula*)
Playing surface: Walnut (*Juglans regia* L.)
PTOPCAJ4MH-M
Resonating body: Eco-friendly medium density fiberboard
Playing surface: Mahogany

FEATURES Passive pickup system with high quality output jack; Individual snare, bass, and tone control; Playing surface with dual internal fixed snare wires; Forward facing sound ports
PTOPCAJ2WN (Turbo Slaptop)
Snares on both sides

7 DIGITAL CAJON

SIZE 12" W x 20" H x 12" D

MATERIALS Resonating body: Birch Wood
Playing surface: Open cell acoustic foam

FEATURES Four rubber trigger pads in a natural cajon playing position; Ten pre-programmed digital sounds

INCLUDES Power supply; Foot switch

COLOUR Black

8 SPEAKER CAJON

SIZE 11 3/4" W x 19 3/4" H x 11 3/4" D

MATERIALS Resonating body: Baltic Birch (*Betula pendula*)
Frontplate: Baltic Birch (*Betula pendula*)

FEATURES Practice to music or incorporate loops in your performances; Supports wireless connection with your phone

INCLUDES Micro SD card

COLOUR Resonating body: Black

9 MINI CAJON SPEAKER

SIZE 5 3/4" W x 8 3/4" H x 5 3/4" D

MATERIALS Resonating body: 5-Ply (6 mm) Baltic Birch (*Betula pendula*)
Frontplate: Baltic Birch (*Betula pendula*)

FEATURES Listen to your favorite music or podcast; Supports wireless, USB and auxiliary connection; Great gift idea for percussionists

10 PERCUSSION MICROPHONE

FEATURES Low-profile condenser microphone with adhesive backing; Great for cajons, congas, djembes or frame drums

INCLUDES Eighth-inch cable to quarter-inch adapter

11 CAJON PREAMP

FEATURES Robust Cajon Pickup/Preamp; Wide range tone control; High-quality signal output; Fits most cajons

MINI & MAKE YOUR OWN CAJONS

1 MINIATURE SIZE OF A CAJON WITH INTERNAL FIXED SNARE WIRES

Almond Birch **MC1AB** Baltic Birch **MC1AB-B** Baltic Birch **MC1B** Burl Wood **MC1BW** Heart Ash **MC1HA**

2 ALL NEEDED TOOLS INCLUDED

Burl Wood **DMYO-CAJ-BU**

DELUXE MODEL FEATURES LARGER SIZE

3

Baltic Birch **MYO-CAJ**

4 POPS UP FROM A FLAT PIECE INTO A FULL SIZE CAJON

Cajon2Go **VR-CAJ2GO**

5

Baltic Birch **MYO-BCAJ**

3 ASSEMBLY INSTRUCTION COMES IN DIFFERENT LANGUAGES

Ovangkol **MYO-CAJ-OV**

6

MYO-TOOLS

1 MINI CAJONS

SIZE 5 3/4" W x 8 3/4" H x 5 3/4" D

MATERIALS **MC1AB**
Resonating body: 5-Ply (6 mm)
Baltic Birch (*Betula pendula*)
Frontplate: Almond Birch (*Betula pendula*)

MC1AB-B
Resonating body: 5-Ply (6 mm)
Almond Birch (*Betula pendula*)
Frontplate: Baltic Birch (*Betula pendula*)

MC1B
Resonating body: 5-Ply (6 mm)
Baltic Birch (*Betula pendula*)
Frontplate: Baltic Birch (*Betula pendula*)

MC1BW
Resonating body: 5-Ply (6 mm)
Baltic Birch (*Betula pendula*)
Frontplate: Burl Wood

MC1HA
Resonating body: 5-Ply (6 mm)
Baltic Birch (*Betula pendula*)
Frontplate: Heart Ash

FEATURES Internal fixed snare wires; Miniature size; Birch construction; Great gift idea

MAKE YOUR OWN **2 3 4**

CONTAINS All of the materials and assembly instructions for completing the cajon

2 DELUXE MAKE YOUR OWN CAJON

SIZE 12" W x 19 1/4" H x 12" D

MATERIALS Resonating body: Baltic Birch (*Betula pendula*)
Frontplate: Burl Wood

INCLUDES All of the tools for completing the cajon

3 MAKE YOUR OWN CAJONS

SIZE 11 3/4" W x 18" H x 11 3/4" D

MATERIALS Resonating body: Baltic Birch (*Betula pendula*)
MYO-CAJ
Frontplate: Baltic Birch (*Betula pendula*)
MYO-CAJ-OV
Frontplate: Ovangkol (*Guibourtia ehie*)
Steel snare wires

COLOUR Natural

4 CAJON2GO

SIZE 13 1/2" W x 18" H x 12 1/2" D

MATERIAL Cardboard

FEATURES Folds from a single flat piece into a full size cajon; Internal fixed set of snare wires; Comfortably holds up to 150 kg / 330 lbs; Naturally deep bass and crisp snare sounds

5 MAKE YOUR OWN BONGO CAJON

SIZE 15 3/4" W x 6 3/4" H x 7 1/4" D

CAJON PEDALS



CAJONS & CAJON PEDALS

7

SPECIALLY POSITIONED CURVED STEEL BAR WITH DIRECT DRIVE



TMSTCP

8 NEW



TMCP-2

9

ADJUSTABLE SPRING TENSION ON BOTH THE PEDAL AND THE MOUNT



TMCP

BASSBOX / SNAREBOX PEDAL (SEE PAGE 57)



TMBP

10

CAN BE PLAYED WITH YOUR HEEL OR TOES



TMSTCP-2

11

FOR PRONOUNCED KICK SOUND



Foam rubber
CPB1

12

ADJUSTABLE BRASS JINGLES



Soft foam
CPB2

13

DELIVERS HEAVY, FULL STROKES



Polymer bristles
CPB3

14

FOR DEEP AND PUNCHY NOTES



Soft foam
CPB4

15

GREAT FOR LOW VOLUME SETTINGS



Artificial fur
CPB5

MATERIAL Baltic Birch (*Betula pendula*)
COLOUR Natural

6 MAKE YOUR OWN CAJON TOOL BOX
CONTAINS 1 x screwdriver; 1 x wood glue; 2 x tension straps; 2 x sanding pads (coarse and fine)
FEATURE One-stop shop for all necessary tools to complete the Meinl Make Your Own Cajons and Bongo Cajon

7 DIRECT DRIVE CAJON PEDAL
MATERIAL Steel
FEATURES Cradle-like mount fits all common cajons; Adjustable spring tension; Natural foot position for ease of use

8 PROFESSIONAL CAJON PEDAL
MATERIAL Steel
FEATURES Position anywhere for optimal playability; For right and left-footed players

9 CAJON PEDAL
MATERIALS Steel; Synthetic
FEATURES Cradle-like mount fits all common cajons; Ultra-smooth and durable cable; Position anywhere for optimal playability
INCLUDES Drum key; Soft foam beater

10 DIRECT DRIVE HEEL ACTIVATED CAJON PEDAL
MATERIAL Steel
FEATURES Simple design for steady bass drum rhythms; Cradle-like mount fits most cajons

11 HAMMER HEAD CAJON & BASS DRUM BEATER
MATERIAL Foam rubber
FEATURES Soft foam rubber draws a deep bass sound from cajons; Dual playing surfaces for a variety of boom and punch

12 JINGLE CONTACT CAJON & BASS DRUM BEATER
MATERIALS Soft foam rubber; Brass jingles
FEATURE Easily turn the jingles on or off as desired throughout your set

13 BRUSH CAJON & BASS DRUM BEATER
MATERIAL Rippled polymer bristles
FEATURES Extra thick set of wavy polymer bristles; Two adjustable control rings; Warm, slightly mellow attack

14 STANDARD CAJON & BASS DRUM BEATER
MATERIAL Soft foam rubber

15 WOOLLY MAMMOTH CAJON BEATER
MATERIALS Artificial fur; Soft foam

CAJON DRUM SETS

1



MORE INFO

MAY BE EASILY ARRANGED FOR RIGHT OR LEFT HANDED PLAYERS



Set
CAJ-DRUMSET

PORTABLE RHYTHM STATION



2



MDTK

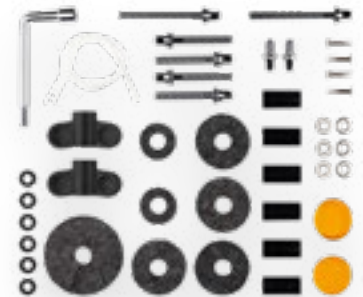

1 CAJON DRUM SET

CONTAINS Birch wood cajon without snares for enhanced bass
Cajon Pedal
Mountable Cajon Snare including silicone protection cover
Multi-Clamp
HCS 13" hi-hat cymbal pair with Low Hat
Bamboo Flex Multi-Rods for Cajon
Cajon Blanket with pockets for accessories
Luis Conte Live Shaker
Cajon Gig Bag

FEATURES

May be easily arranged for right or left handed players
This set includes everything needed for players looking to perform their normal drum set rhythms in smaller, intimate acoustic settings
The elements of this set give you the same feeling as sitting down at a drum kit

2 DRUM TECH KIT

CONTAINS 1 x L-Shaped Drum Key
4 x Drum Honey Gel Pads
6 x Synthetic Cymbal Sleeves
4 x Steel Cymbal Rivets
4 x Cymbal Felts
2 x Hi-hat Clutch Felts
1 x Hi-hat Base Felt
2 x 8 mm Wing Nuts
6 x Metal Washers
6 x Synthetic Washers
2 x Nylon Snare Cords
2 x Short Tension Rods
4 x Medium Tension Rods
2 x Long Tension Rods

FEATURES

Includes 14 of the most common and important tools for drummers and techs; For gig emergencies, routine maintenance, restoration or replacing lost parts

INCLUDES

Storage container for organization

CONVERTS ANY STANDARD CAJON INTO A BASS DRUM

3



MORE INFO



Set
CAJ-KIT

4

CUTTING SNARE SOUND



MCS1-BK



5

SHIELDS YOUR SNARE CAJON FROM STICK MARKS OR SCRATCHES



SCOVER



3 CAJON DRUM SET CONVERSION KIT

- CONTAINS** Direct Drive Cajon Pedal
Mountable Cajon Snare including silicone protection cover
Multi-Clamp
HCS 13" hihat cymbal pair with Low Hat
Bamboo Flex Multi-Rods for Cajon
Cajon Blanket with pockets for accessories
Luis Conte Live Shaker
Cajon Gig Bag

- FEATURES** Converts any standard cajon into a bass drum (cajon not included)
Expand your cajon into a small, reduced volume drum set
Low-key stage footprint
Perfect for acoustic shows, jam sessions, or street performances

4 MOUNTABLE CAJON SNARE

- SIZE** 7 1/2"
MATERIAL Siam Oak (*Hevea brasiliensis* Muell.-Arg.)
FEATURES Internal Snare Wires
Standard 3/8" rod mounting bracket
INCLUDES L-shaped rod with knurled surface
COLOUR **BK**: Black

5 SILICONE PROTECTION COVER

- SIZE** 7 1/2"
MATERIAL Silicone
FEATURES Shields your snare cajon from stick marks or scratches
Removable at any time

CAJON DRUM SETS



1 COCKTAIL CAJON KIT

CONTAINS Cocktail Cajon; Tom Tap; Snare Tap; Bongo Cajon Tap; Husk Brush (SB307); Foot Pedal (TMBP); Pedal Beater (CPB4); 3 x L-shaped rod (MC-R5); Splitter

2 KICK DRUM CAJON

SIZE 11 3/4" W x 19 3/4" H x 11 3/4" D
MATERIALS Resonating body: 7-Ply (9 mm) Baltic Birch (*Betula pendula*)
Frontplate: Baltic Birch (*Betula pendula*)
FEATURES Multiple attachments to build an acoustic drum setup; Full size cajon without snares or strings for pure bass tone
INCLUDES Cymbal arm; Z-shape rod (plus mounts); pedal attachment plate; cajon beater

3 COMPACT PERCUSSION PAD

SIZE 6 1/2"
MATERIAL ABS

FEATURES 5 pre-programmed sounds; Ideal for multi-instrumentalists and percussionists; Sensitive rubber surface for responsive hand and stick notes

INCLUDES Rechargeable battery and USB-C cable 9000, SDS & 808 Snare, Tambourine, Hand Clap

4 THE ULTIMATE PERCUSSION SAMPLE BOX

MATERIAL Aluminum
FEATURES Converts the input signal into percussion sound effects; Can use any analog stomp box or electronic trigger pad as signal generator; Controller for volume, sound selection, touch response; High-quality 1/4" TRS input and output jack; 3/8" eye bolt mount; Rechargeable battery and USB-C included (cable not included); Built-in OLED screen

5 MERGER

MATERIAL Aluminum
FEATURES Combine multiple percussion audio signals into one output; Contains 6 inputs, 1 XLR output and 1 AUX input

6 INSTRUMENT CABLES

SIZES **MPIC-5:** 5 ft / 1.5 m
MPIC-10: 10 ft / 3 m
MPIC-15: 15 ft / 4.5 m
MPIC-20: 20 ft / 6 m
MPIC-30: 30 ft / 9 m
FEATURES 8 mm diameter with high-quality 1/4" straight connectors; Wire gauge: 24 AWG

7 COCKTAIL CAJON INSTRUMENT CABLE SET

CONTAINS 4 x 5 ft Instrument Cable (MPIC-5)
1 x 30 ft Instrument Cable (MPIC-30)
FEATURE 5-piece Meinl Percussion Instrument Cable set for the Meinl Cocktail Cajon Kit



8 STANDARD CAJON BRUSHES INCLUDED

TMPPCS



MIN. 27"
MAX. 42"

CHS

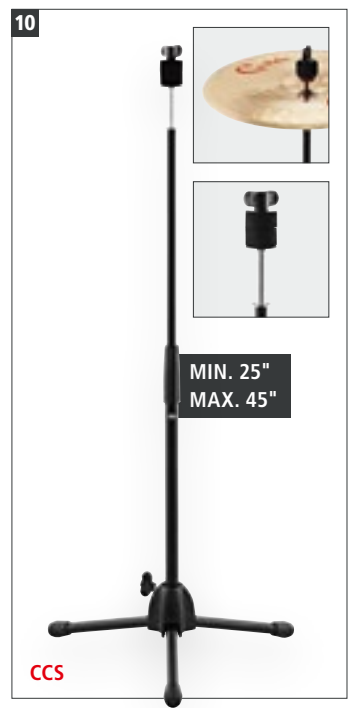

MIN. 25"
MAX. 45"

CCS



MIN. 22"
MAX. 37"

CAS



CJT



CST



CTT



INCLUDES SILICONE PROTECTION COVER

MCS2-BK

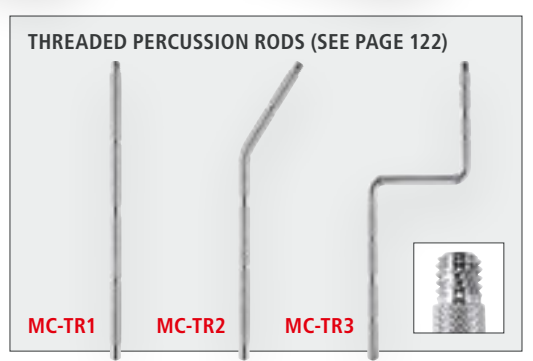

THREADED PERCUSSION RODS (SEE PAGE 122)

MC-TR1

MC-TR2

MC-TR3

8 PROFESSIONAL PICKUP CAJON SNARE

SIZE 13" W x 6" H x 13" D
MATERIALS Resonating body: MDF
 Playing surface: American White Ash (*Fraxinus Americana* L.)
INCLUDES Standard Cajon Brushes (SB305)

CAJON DRUM SET STANDS 9 10 11

MATERIAL Black powder coated steel
FEATURE Foldable legs, height adjustable

9 CAJON HIHAT STAND

FEATURES Standard hihat clutch and padded seat;
 Fixed internal rod for closed hihat sound

10 CAJON CYMBAL STAND

FEATURES Standard cymbal stand top;
 Use with any cymbal type

11 CAJON ADD-ON STAND

FEATURE 3/8" threaded connector top

CAJON TAPS 12 13 14

SIZE 5 3/4"
MATERIAL Siam Oak (*Hevea brasiliensis* Muell.-Arg.)
FEATURE Threaded 3/8" connection underneath
FINISH Black

12 CAJON JINGLE TAP

FEATURE Stainless steel jingles for bright accents

13 CAJON SNARE TAP

FEATURE Internal snares for high pitched snare cajon sound

14 CAJON TOM TAP

FEATURE Hollow inside for a high pitched "tom" sound

15 MOUNTABLE CAJON SNARE WITH THREADED 3/8" CONNECTION

SIZE 7 1/2"
MATERIAL Siam Oak (*Hevea brasiliensis* Muell.-Arg.)
INCLUDES Silicone Protection Cover
COLOUR BK: Black

CAJON ADD-ONS

1



DESIGNED TO HOLD OUR CAJON ADD-ONS CLOSE TO THE PLAYING SURFACE

Medium **CSM-M** Large **CSM-L**

2



WC1-M

3

STAINLESS STEEL JINGLES



WJ1-M

4

ADD NEW SOUNDS TO YOUR CAJON



JT-S-BK

5

EXTRA POCKET FOR SMALL PERCUSSION



CAJ-BLK

6

STAINLESS STEEL JINGLES



WSS1BK

7

INTERNAL SNARE EFFECT



CCAB-S **CCAB**

8



TMCTK

1 CAJON SIDE MOUNTS

SIZES **M:** Medium
L: Large

MATERIAL Siam Oak (*Hevea brasiliensis* Muell.-Arg.)

FEATURES Easy handling; Hook and loop fastener goes on any surface; Offers better cajon accessory placement

COLOUR Black

2 CAJON CASTANET

SIZE **M:** Medium

MATERIAL Siam Oak (*Hevea brasiliensis* Muell.-Arg.)

FEATURES Spring-opened; Hook and loop fastener goes on any surface

COLOUR Black

FINISH Matte

3 CAJON JINGLE CASTANET

SIZE **M:** Medium

MATERIAL Siam Oak (*Hevea brasiliensis* Muell.-Arg.)

FEATURES Spring-opened; Hook and loop fastener goes on any surface; Stainless steel jingles

COLOUR Black

FINISH Matte

4 JINGLE TAP

SIZE Medium

MATERIAL Siam Oak (*Hevea brasiliensis* Muell.-Arg.)

FEATURES Stainless steel jingles; Hook and loop fastener goes on any surface

COLOUR **BK:** Black

5 CAJON BLANKET

MATERIAL Heavy-duty nylon

FEATURES Fits on any cajon; Hook and loop fastener to mount additional add-ons

COLOUR Black

6 WOOD SIDE SNARE

MATERIAL Siam Oak (*Hevea brasiliensis* Muell.-Arg.)

FEATURES Internal snare effect; Hook and loop fastener attaches to Cajon body; Ergonomic shape; Unobtrusive low profile

COLOUR **BK:** Black

FINISH Matte

7 CAJON TURBO CABASAS

SIZES **CCAB-S:** Small
CCAB: Medium (traditional size)

MATERIALS Steel chain and stainless steel cylinder

FEATURES Add cabasa or loose hihat effects to cajon grooves; Five sound ports for extra projection

8 CAJON KINETIC TUNING KEY

MATERIAL Molded ABS

FEATURES Adjust cajon string tension and cajon frontplate screws; Dual crosshead screw-driver and hex key; Wide wing Meinl logo designed for a firm grip

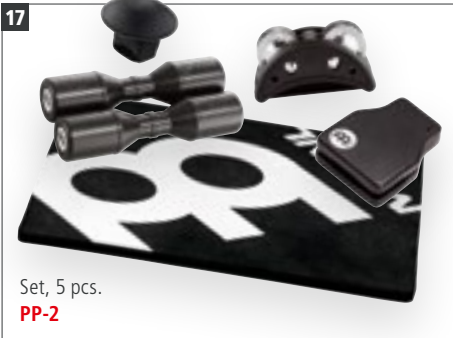

9 KNEE PAD JINGLE TAP & KNEE PAD SNARE TAP
MATERIAL Siam Oak (*Hevea brasiliensis* Muell.-Arg.)
FEATURES Strap with hook and loop fastener to mount on your leg
KP-JT-BK: Stainless steel jingles
KP-ST-BK: Snare effect
COLOUR **BK:** Black

10 MOTION SHAKER
MATERIAL Synthetic
FEATURES Comfortable to wear on your fingers; Cutting shaker sound
COLOUR **BK:** Black

11 CAJON RING CASTANETS
SIZE Large
MATERIALS **CRC1BK:** Siam Oak (*Hevea brasiliensis* Muell.-Arg.)
PCRC1BK: Synthetic

COLOUR **BK:** Black
12 FINGER JINGLES
MATERIALS Siam Oak (*Hevea brasiliensis* Muell.-Arg.)
FJS1A: Aluminum jingles
FJS1S: Stainless steel jingles

13 CAJON PEDAL MOUNT
MATERIAL Baltic Birch (*Betula pendula*)
FEATURES Play your cajon just like a kick drum; Accommodates any size cajon; Fits all bass drum pedals; Adjustable wooden plate secures your cajon

14 SYNTHETIC LEATHER CAJON SEATS
MATERIAL Sleek faux leather
FINISHES **GR:** Grey
VBR: Vintage Brown

15 DELUXE CAJON SEATS
SIZE 9 3/4" x 9 1/2"
MATERIALS Inner material foam
 Outer material leatherette
FEATURES Provides comfort while sitting on your cajon; Filled with extra-thick padding; Elegant cross-stitching for high-end look and durability; Special underside surface grips any cajon (no adhesives necessary)
COLOURS **DCS:** Black
DCS-R: Bordeaux

16 CAJON PAD
SIZE 10" x 10"
MATERIAL Soft foam

17 CAJON PERC PACK
CONTAINS Cajon Pad; Compact Foot Tambourine; Motion Shaker; Cajon Castanet, large; Luis Conte Live Shaker

PERCUSSION STOMP BOXES & EFFECTS PEDALS

1

Kick
STB1

Cowbell
STB2

Clap
STB3

Tambourine
STB4

2 **NEW**

12 sounds
STB6

NEW

14 sounds
STB7

3

CREATES A FOOT STOMPING ANALOG SIGNAL

Analog
MPS1

HiHat
STB5

NEW

16 sounds
STB8

4

FX5

FX20

A WHOLE PERCUSSION KIT IN A BOX

5

MPTP

1 PERCUSSION STOMP BOXES

MATERIAL Aluminum

FEATURES Create hands-free beats by tapping your foot; Pre-programmed percussion sound effect; Perfect for cajon players, guitarists and multi-instrumentalists; High-quality 1/4" output jack

SOUNDS **STB1:** Kick
STB2: Cowbell
STB3: Clap
STB4: Tambourine
STB5: HiHat

2 THE ULTIMATE STOMP BOXES

MATERIAL Aluminum

FEATURES Create hands-free beats by tapping your foot; Perfect for cajon players, guitarists or multi-instrumentalists; High-quality 1/4" TRS input and output jack; Runs with 2 x AA 1.5V batteries (not included)

SOUNDS **STB6:** Kick Bass; Pop Kick; Soft Kick; 808 Bass; 909 Bass; SDS Bass; Cannon Kick; Doom Kick; Bass 'n' Ride; Oriental; Doumbek Bass; 808 Subkick
STB7: Soul Snare; 9000 Snare; 909 Snare; 808 Snare; Brass Snare; SDS Snare; Pop Snare; Doumbek Slap; HipHop Snare; Reggae Snare; Snare + Clap; Snare + Tambourine; Brush Snare; Sidestick
STB8: Tambourine; Cowbell; Clap; Shaker; Pedal Hihat; Woodblock; Bongo; Conga; Darbuka; Timbale; Djembe; Slight Bell; Maracas; Claves; Guiro; Crasher

3 PERCUSSION STOMP BOX, ANALOG

MATERIAL Solid Mahogany body

FEATURES Perfect for percussionists and multi-instrumentalists; 1/4" input and output jacks; Creates a foot stomping analog signal; Built-in Piezo pickups with volume control

INCLUDES L-shaped soft foam beater

4 EFFECTS PEDALS

MATERIALS ABS; Steel

FEATURES Ideal for multi-instrumentalists and percussionists
FX5: 5 pre-programmed sounds; Hands-free beats
FX20: Ten pre-programmed percussion samples and ten custom samples; Weighted body for a sturdy feel; Highly dynamic pedal with smooth spring back an no sound interference

INCLUDES **FX5:** Rechargeable battery, USB-C cable
FX20: Micro SD card and power supply with international adapters

SOUNDS **FX5:** Pop; Doom; SDS; 808 Sub; Soft Kick
FX20: Kick Bass; Soft Kick; 808 Bass; 808 Snare; HiHat; Clave; Hand Clap; Cowbell; Straight Tambourine; Shaker

BASSBOXES & SNAREBOXES



FOOT PERCUSSION

6 ALUMINUM RAIL TO MOUNT ANY COMMON FOOT PEDAL



Bassbox
BASSBOX

IMMENSE BASS SOUND



Pickup Bassbox
PBASSBOX

L-SHAPED SOFT FOAM BEATER INCLUDED

7 TWO INTERNAL SNARE WIRES



Snarebox
SNAREBOX

CRISP SNARE SOUND



Pickup Snarebox
PSNAREBOX

L-SHAPED FELT BEATER INCLUDED

8



Soft foam
BBB2

9



Felt
SBB1

10



Brass jingles
BBB1

11



Foam rubber
BBB3

12



Artificial fur
BBB4

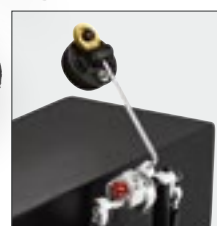

13 PERFECT FOR THE MEINL BASSBOX AND SNAREBOX



TMBP



5 TRIGGER PEDAL
MATERIAL ABS; Steel
FEATURES Pedal activated trigger; Transmits sounds from your sound module; Hands-free use

6 BASSBOX & PICKUP BASSBOX
SIZE 17 1/2" W x 6 3/4" H x 11 3/4" D
MATERIAL Resonating body: Baltic Birch (*Betula pendula*)
FEATURES Perfect for guitarists and singers; Immense bass sound
PBASSBOX: Piezo pickup with high quality output jack
INCLUDES L-shaped soft foam beater
COLOUR Black
FINISH Matte

7 SNAREBOX & PICKUP SNAREBOX
SIZE 7 1/2" W x 7 1/2" H x 13" D
MATERIAL Baltic Birch (*Betula pendula*)

FEATURES Perfect for guitarists and singers
PSNAREBOX: Piezo pickup with high quality output jack
INCLUDES L-shaped felt beater
COLOUR Black
FINISH Matte

8 BASSBOX BEATER
MATERIAL Soft foam rubber
FEATURE Punchy response

9 SNAREBOX BEATER
MATERIAL Felt
FEATURE Crisp snare response

10 JINGLE CONTACT BASSBOX/SNAREBOX BEATER
MATERIALS Soft foam rubber; Brass jingles
FEATURE Soft L-shaped foam rubber beater with adjustable brass jingles

11 HAMMER HEAD BASSBOX/SNAREBOX BEATER
MATERIAL Foam rubber
FEATURES Hammer Head shape for a pronounced kick sound; Dual playing surfaces for boom or punch; Draws out a naturally deep tone

12 WOOLLY MAMMOTH BASSBOX/SNAREBOX BEATER
MATERIALS Artificial fur; Soft foam
FEATURES Woolly Mammoth beater produces a soft kick sound; Delivers a mellow attack for low volume and texture

13 BASSBOX/SNAREBOX PEDAL
MATERIAL Steel
FEATURE Adjustable spring tension to dial in your comfort zone

FOOT PERCUSSION

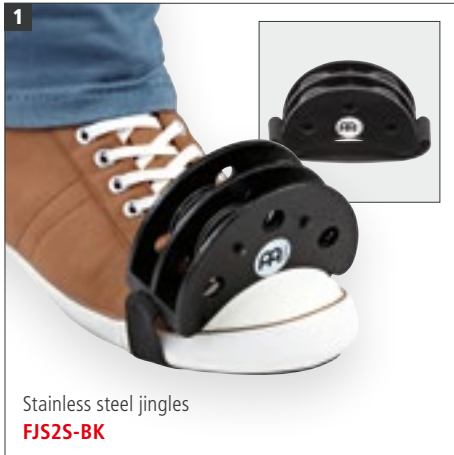

Stainless steel jingles
FJS2S-BK



Stainless steel jingles
CFJS2S-BK



Stainless steel jingles
CFT5-BK



Synthetic
FS-BK



Siam Oak, Synthetic
CFC-BK



Stainless steel jingles
HTA



Stainless steel jingles
PHTA



Synthetic
HSH

1 FOOT TAMBOURINE
MATERIALS Siam Oak (*Hevea brasiliensis* Muell.-Arg.)
 Stainless steel jingles
FEATURE Hassle-free mounting

2 COMPACT FOOT TAMBOURINE
MATERIALS Synthetic
 Stainless steel jingles
FEATURE Attaches quickly and easily to foot via elastic strap

3 CAJON FOOT TAMBOURINE
MATERIALS Siam Oak (*Hevea brasiliensis* Muell.-Arg.)
 Stainless steel jingles
FEATURES 5 pairs of stainless steel jingles
 Easily mountable

4 FOOT SHAKER
MATERIAL Synthetic
FEATURES Easy mountable
 Shaker mounted at a special angle for precise control

5 CAJON FOOT CASTANET
MATERIALS Siam Oak (*Hevea brasiliensis* Muell.-Arg.)
 Synthetic
FEATURES Traditional castanet sound
 Easily mountable
 Pair of synthetic castanets

6 HEEL TAMBOURINE
MATERIALS Siam Oak (*Hevea brasiliensis* Muell.-Arg.)
 Synthetic
 Stainless steel jingles
FEATURES Stainless steel jingles for a bright full sound
 Shoehorn design fits comfortably against your heel
 Great accessory for hands free playing

7 PROFESSIONAL HEEL TAMBOURINE
MATERIALS Siam Oak (*Hevea brasiliensis* Muell.-Arg.)
 Synthetic
 Stainless steel jingles
FEATURES Stainless steel jingles for a bright, full sound
 Adjustable mounting system fits perfectly against your heel
 Great accessory for hands-free playing



Siam Oak
FR1NT



Bendo seeds
FR1B



BENNY GREB SIGNATURE TAMBOSTEP
(SEE PAGE 78)



BG-TS



Kenen seeds
FR1K



Pangi seeds
FR1P

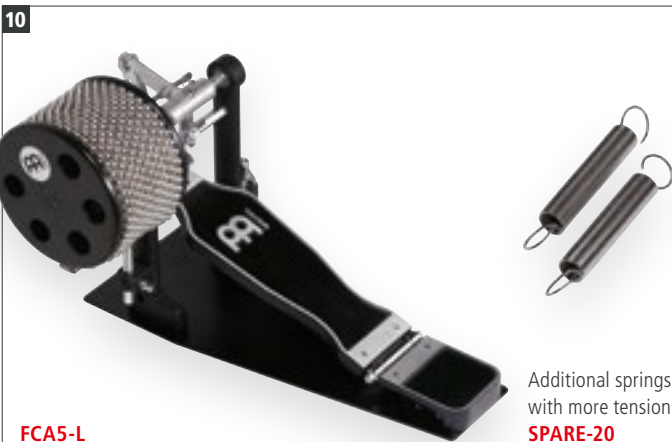

FCA5-L



Additional springs
with more tension
SPARE-20



Set, 2 pcs.
MPTH5

USE YOUR FOOT TO EASILY
TAP ON THE TAMBOURINE

8 HEEL SHAKER

MATERIAL Synthetic
FEATURES Great accessory for hands-free playing
Shoehorn design fits comfortably against
your heel

9 FOOT RATTLES

MATERIALS **FR1NT:** Siam Oak
(*Hevea brasiliensis* Muell.-Arg.)
FR1B: Bendo seed nutshells
FR1K: Kenen seed nutshells
FR1P: Pangi seed nutshells
FEATURES Hands-free – straps securely and comfortably around your ankle
Creates a hollow wooden shaker effect with warmth and depth
Equipped with hook-and-loop strap for a universally adjustable fit

10 FOOT CABASA (PATENTED)

SIZE Large
MATERIALS Steel chain and stainless steel cylinder
Wooden body
Black powder coated pedal
FEATURES Optional single or double-stroke setting
5 sound ports on each side for more volume
INCLUDES Drum key
Foot pedal

11 TAMBOURINE HOLDER SET

MATERIAL Baltic Birch (*Betula pendula*)
CONTAINS Tambourine Holder
Headliner® Series Hand Held ABS
Tambourine (HTBK)
FEATURE Perfect for cajon players, guitarists and singers

DJEMBES





The djembe is a powerful and expressive hand drum with origins in West African culture, known for its rich tonal range and deep cultural significance. Crafted traditionally from wood and goat skin, this versatile instrument can produce booming bass, sharp slaps, and resonant tones, making it perfect for dynamic performances and drum circles. Whether you're playing traditional African rhythms or blending it into modern music, the djembe's voice adds an authentic, earthy energy. Easy to play yet full of depth, the djembe is a must-have for percussionists seeking to connect with rhythmic roots and global traditions.

ROPE TUNED TRAVEL & JR. DJEMBS

1

GALACTIC BLUE TIE DYE



12" **PADJ8-L-F**

10" **PADJ8-M-F**

DAY OF THE DEAD



12" **PADJ7-L-F**

10" **PADJ7-M-F**

KANGA SARONG



12" **PADJ6-L-F**

10" **PADJ6-M-F**

SIMBRA



12" **PADJ5-L-F**

10" **PADJ5-M-F**

PHARAOH'S SCRIPT



14" **PADJ1-XL-F**

12" **PADJ1-L-F**

10" **PADJ1-M-F**

8" **PADJ1-S-F**

KENYAN QUILT



14" **PADJ2-XL-F**

12" **PADJ2-L-F**

10" **PADJ2-M-F**

8" **PADJ2-S-F**

1 ROPE TUNED TRAVEL SERIES DJEMBS, SYNTHETIC HEAD (PATENTED)

SIZES

- S:** 8" diameter, 16" tall
- M:** 10" diameter, 20" tall
- L:** 12" diameter, 24" tall
- XL:** 14" diameter, 26" tall

HTP ROPES

- S:** 4 mm thickness, 20 runners
- M:** 4 mm thickness, 25 runners
- L:** 4 mm thickness, 30 runners
- XL:** 5 mm thickness, 35 runners

MATERIALS Synthetic shell; Synthetic head

FEATURES 100% synthetic heads and shells are perfect for outdoor playing; Ultra light weight makes them easy to carry; Pre-stretched HTP nylon ropes; Produces sharp slaps and deep bass tones; Non-slip rubber bottom to protect the drum from scratches

FINISHES

- PADJ1:** Pharaoh's Script
- PADJ2:** Kenyan Quilt
- PADJ5:** Simbra
- PADJ6:** Kanga Sarong
- PADJ7:** Day of the Dead
- PADJ8:** Galactic Blue Tie Dye



SYNTHETIC DJEMBES



2 JR. DJEMBES

SIZE 7" diameter, 12 1/2" tall
ROPE 14 runners
MATERIALS Synthetic shell; Synthetic head
FEATURES Grab-and-go for any occasion, indoors or outside; Compact size and lightweight shell; Pre-stretched ropes; Produces sharp slaps and deep bass tones; 100% synthetic head and shell are perfect for outdoor playing
COLOURS **B:** Blue
BK: Black
G: Green
O: Orange
R: Red
Y: Yellow

FINISHES **GB:** Galactic Blue Tie Dye
KQ: Kenyan Quilt
PS: Pharaoh's Script
SI: Simbra
TA: Twisted Amber
TD: Tie Dye

3 ROPE TUNED TRAVEL SERIES DJEMBES, GOATSKIN HEAD (PATENTED)

SIZES **S:** 8" diameter, 16" tall
M: 10" diameter, 20" tall
L: 12" diameter, 24" tall
XL: 14" diameter, 26" tall
HTP ROPES **S:** 4 mm thickness, 20 runners
M: 4 mm thickness, 25 runners
L: 4 mm thickness, 30 runners
XL: 5 mm thickness, 35 runners

MATERIALS Synthetic shell
PADJ1, PADJ2 Hand selected goatskin head
PADJ4 Black coloured hand selected goatskin head
FEATURES Goatskin heads give you authentic sound and feel; Synthetic shells are perfect for outdoor playing; Ultra light weight makes them easy to carry; Pre-stretched HTP nylon ropes; Produces sharp slaps and deep bass tones; Non-slip rubber bottom to protect the drum from scratches
FINISHES **PADJ1:** Pharaoh's Script
PADJ2: Kenyan Quilt
PADJ4: Phantom Black

JUMBO DJEMBES

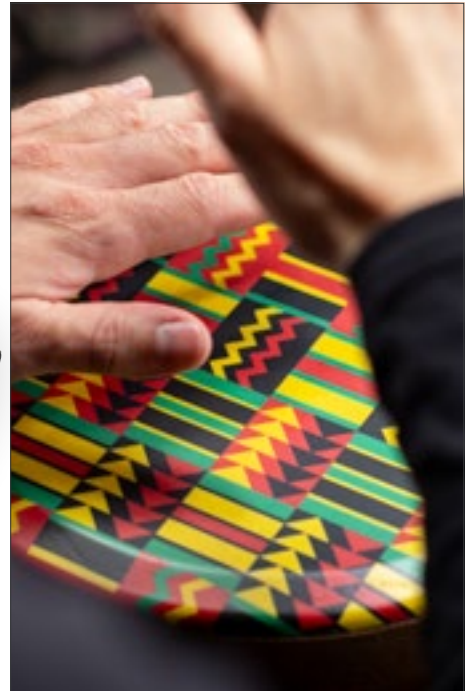

1 JUMBO DJEMBES

SIZES **JD10:** 10" diameter, 20 1/2" tall
JD12: 12" diameter, 24" tall
JD14: 14" diameter, 26" tall

MATERIALS Synthetic shell
 Synthetic head

FEATURES Jumbo size for deep bass tone
 100% all-weather synthetic shell and head
 Easy to use mechanical tuning system
 Lightweight construction to travel easily

FINISHES **BW:** Barnwood
DA: Day of the Dead
DA-DH: Day of the Dead, designer head
SI: Simbra
SI-DH: Simbra, designer head

2 JUMBO DJEMBE SYNTHETIC HEADS

SIZES **HEAD-JD10:** 10"
HEAD-JD12: 12"
HEAD-JD14: 14"

MATERIALS Synthetic head

FEATURES For the Meinl Jumbo Djembe
 100% synthetic all-weather head

FINISHES **BK:** Black leather cloth
DA: Day of the Dead
SI: Simbra
WH: White Fiberskin
Y: Yellow Fiberskin

3 COMMUNITY CONGAS

SIZES **TU10SI:** 10" diameter, 25 1/2" tall
TU12SI: 12" diameter, 25 1/2" tall
TU14SI: 14" diameter, 25 1/2" tall

MATERIALS Synthetic shell
 Synthetic head

FEATURES Great for drum circles and students
 Warm open tones
 Indoor/outdoor
 Easy to play and tune

FINISH **SI:** Simbra

2

10" HEAD-JD10WH 10" HEAD-JD10Y 10" HEAD-JD10DA 10" HEAD-JD10SI 10" HEAD-JD10BK

12" HEAD-JD12WH 12" HEAD-JD12Y 12" HEAD-JD12DA 12" HEAD-JD12SI 12" HEAD-JD12BK

14" HEAD-JD14WH 14" HEAD-JD14Y 14" HEAD-JD14DA 14" HEAD-JD14SI 14" HEAD-JD14BK

3

SIMBRA

14" TU14SI 12" TU12SI 10" TU10SI

4

SIMBRA

12" TI12SI

5

SIMBRA

14" TIM14SI

6

STACKABLE FOR EASY STORAGE AND TRANSPORTATION

CAN BE TAKEN OFF THE DRUM INSTANTLY WITHOUT ANY TUNING

BOOM SERIES

SOFT SOUND SERIES

Set, 2 pcs. VR-SDSET-SH

Set, 2 pcs. VR-SDSET-NH

4 COMMUNITY TIMBAU

SIZE 12" diameter, 23 1/2" tall

MATERIALS Synthetic shell
Synthetic head

FEATURES Great for drum circles and students
Warm open tones
Indoor/outdoor
Easy to play and tune

FINISH **SI:** Simbra

5 COMMUNITY TIMBA

SIZE 14" diameter, 39 1/2" tall

MATERIALS Synthetic shell
Synthetic head

FEATURES Great for drum circles and students
Warm open tones
Indoor/outdoor
Easy to play and tune

FINISH **SI:** Simbra

6 STACK DRUM SETS

SIZES 9 1/2" diameter, 17 1/4" tall
12" diameter, 24" tall

MATERIALS Synthetic shell
SH: Synthetic head
NH: Napa head

FEATURES Synthetic shell is perfect for outdoor playing; Stackable for easy storage and transportation; Non-slip rubber bottom; Great for any skill level or style
SH: Pre-tuned synthetic head for cutting sounds with sharp attack
NH: Pre-tuned Napa head creates softer, warmer sound

ALPINE DJEMBES

1

GALACTIC BLUE TIE DYE



12" **ADJ12-GB** 10" **ADJ10-GB**

DAY OF THE DEAD



12" **ADJ12-DA** 10" **ADJ10-DA**

2

PIEZO PICKUP AND VOLUME CONTROL



BARNWOOD

12" **PADJ12-BW**

KANGA SARONG



12" **ADJ12-KA** 10" **ADJ10-KA**

SIMBRA



12" **ADJ12-SI** 10" **ADJ10-SI**

BARNWOOD



12" **ADJ12-BW** 10" **ADJ10-BW**

1 ALPINE SERIES DJEMBES

- SIZES** **ADJ10:** 10" diameter, 20" tall
ADJ12: 12" diameter, 24" tall
- MATERIALS** Synthetic shell
Synthetic head
- FEATURES** Durable, synthetic head and shell
Ultra light weight
Mechanical tuning system
Perfect for travel and outdoor performance
- FINISHES** **BW:** Barnwood
DA: Day of the Dead
GB: Galactic Blue Tie Dye
KA: Kanga Sarong
SI: Simbra

2 PICKUP ALPINE SERIES DJEMBE

- SIZE** 12" diameter, 24" tall
- MATERIALS** Synthetic shell
Synthetic head
- FEATURES** 100% synthetic djembe; Piezo pickup and volume control; Mechanically tuned head; Great for outdoor performances
- FINISH** **BW:** Barnwood

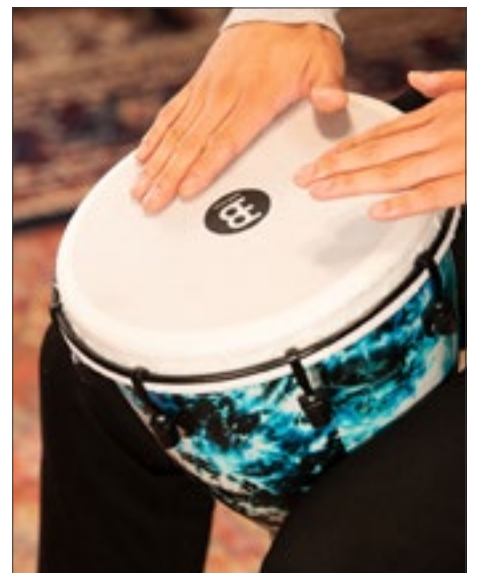

POP OFF & 3-IN-1 DJEMBES



3

MAY BE PLAYED BY THEMSELVES AS A SMALL HAND DRUM

14" 12" 10" 9" 8" 14" 12" 10" 9" 8"

VR-POH14-SH VR-POH12-SH VR-POH10-SH VR-POH9-SH VR-POH8-SH VR-POH14-NH VR-POH12-NH VR-POH10-NH VR-POH9-NH VR-POH8-NH

SYNTHETIC DJEMBES

4

BOOM SERIES

SOFT SOUND SERIES

CAN BE TAKEN OFF THE DRUM INSTANTLY WITHOUT ANY TUNING

14" x 26 1/4" 12" x 23" 10" x 19 1/2" 9" x 16 1/2" 8" x 16 1/4"

VR-SDJPO14-SH VR-SDJPO12-SH VR-SDJPO10-SH VR-SDJPO9-SH VR-SDJPO8-SH

14" x 26 1/4" 12" x 23" 10" x 19 1/2" 9" x 16 1/2" 8" x 16 1/4"

VR-SDJPO14-NH VR-SDJPO12-NH VR-SDJPO10-NH VR-SDJPO9-NH VR-SDJPO8-NH

5

BOOM SERIES

SOFT SOUND SERIES

Set, 3 pcs. VR-SDJSET-SH

THE POP OFF DJEMBE HEADS MAY BE PLAYED BY THEMSELVES AS A SMALL HAND DRUM

Set, 3 pcs. VR-SDJSET-NH

STACKABLE FOR EASY STORAGE AND TRANSPORTATION

3 POP OFF HEADS

SIZES VR-POH8: 8" head diameter
VR-POH9: 9" head diameter
VR-POH10: 10" head diameter
VR-POH12: 12" head diameter
VR-POH14: 14" head diameter

MATERIALS SH: Synthetic head
NH: Napa head

FEATURES Available as Napa style (soft sound) or standard synthetic (sharp sounds)
Instantly take on or off your Meinl Pop Off Djembe
May be played by themselves as a small hand drum
Nylon-loop for easy removal
Pre-tuned

4 POP OFF DJEMBES

SIZES VR-SDJPO8: 8" head diameter, 16 1/4" height
VR-SDJPO9: 9" head diameter, 16 1/2" height
VR-SDJPO10: 10" head diameter, 19 1/2" height
VR-SDJPO12: 12" head diameter, 23" height
VR-SDJPO14: 14" head diameter, 26 1/4" height

MATERIALS Synthetic shell
SH: Synthetic head
NH: Napa head

FEATURES Synthetic shell is perfect for outdoor playing
Non-slip rubber bottom
Great for any skill level or style
SH: Removable, pre-tuned synthetic head for cutting sounds with sharp attack

NH: Removable, pre-tuned Napa head creates softer, warmer sound

5 3-IN-1 DJEMBES

SIZES 8" head diameter, 16 1/4" height
10" head diameter, 19 1/2" height
12" head diameter, 23" height

MATERIALS Synthetic shell
SH: Synthetic head
NH: Napa head

FEATURES Synthetic shell is perfect for outdoor playing
Non-slip rubber bottom
Great for any skill level or style
Stackable for easy storage and transportation
SH: Pre-tuned synthetic head for cutting sounds with sharp attack
NH: Pre-tuned Napa head creates softer, warmer sound

ROPE TUNED HEADLINER® WOOD DJEMBES



ROPE TUNED HEADLINER® SERIES WOOD DJEMBES 1 2 3 4

SIZES

- S:** 8" diameter, 15 3/4" tall
- M:** 10" diameter, 20" tall
- L:** 12" diameter, 24" tall
- XL:** 13" diameter, 25" tall

PP ROPES

- S:** 4 mm thickness, 16 runners
- M:** 4 mm thickness, 18 runners
- L:** 5 mm thickness, 20 runners
- XL:** 6 mm thickness, 24 runners

1 NILE SERIES

MATERIALS Mahogany Wood (*Swietenia macrophylla*)
Hand selected goatskin heads

FEATURES Carved from one solid piece of plantation grown Mahogany Wood
Pre-stretched PP nylon ropes
Hand carved shells

COLOUR Brown

2 BLACK RIVER SERIES

MATERIALS Mahogany Wood (*Swietenia macrophylla*)
Hand selected goatskin heads

FEATURES Carved from one solid piece of plantation grown Mahogany Wood
Pre-stretched PP nylon ropes
Hand carved shells

COLOUR Black

3 ARTIFACT SERIES

MATERIALS Mahogany Wood (*Swietenia macrophylla*)
Hand selected goatskin heads

FEATURES Carved from one solid piece of plantation grown Mahogany Wood
Pre-stretched PP nylon ropes
Hand carved shells

COLOUR Brown

4 CONGO SERIES

MATERIALS Mahogany Wood (*Swietenia macrophylla*)
Hand selected goatskin heads

FEATURES Carved from one solid piece of plantation grown Mahogany Wood
Pre-stretched PP nylon ropes
Hand carved shells
Ornamental carving

COLOUR Dark Brown

MINI & ROPE TUNED WOOD DJEMBES



5

Python Design, 4 1/2"
HDJ5-XXS

Dark Serpent Design, 4 1/2"
HDJ6-XXS

Gecko Design, 4 1/2"
HDJ7-XXS

Flower Design, 4 1/2"
HDJ8-XXS

6

BLACK COLOURED HAND SELECTED GOATSKIN HEADS

FIRE RHYTHM SERIES

13"
ADJ7-XL

12"
ADJ7-L

10"
ADJ7-M

EARTH RHYTHM SERIES

13", bundle with bag
ADJ3-XL+BAG

12", bundle with bag
ADJ3-L+BAG

10", bundle with bag
ADJ3-M+BAG

WATER RHYTHM SERIES

13", bundle with bag
ADJ2-XL+BAG

12", bundle with bag
ADJ2-L+BAG

10", bundle with bag
ADJ2-M+BAG

WOOD DJEMBES

5 AFRICAN STYLE MINI DJEMBES

SIZE 4 1/2" (4 1/4" - 4 3/4") diameter, 8" tall
PP ROPE 3 mm thickness, 10 runners
MATERIALS Mahogany Wood (*Swietenia macrophylla*)
 Hand selected goatskin head
FEATURES Carved from one solid piece of plantation grown Mahogany Wood
 High quality PP nylon rope
 Hand painted shell
FINISHES **HDJ5:** Python Design
HDJ6: Dark Serpent Design
HDJ7: Gecko Design
HDJ8: Flower Design

6 ORIGINAL AFRICAN STYLE ROPE TUNED WOOD DJEMBES

SIZES **M:** 10" (9 1/4" - 10 1/4") diameter, 20" tall
L: 12" (10 3/4" - 12 1/4") diameter, 24" tall
XL: 13" (12 3/4" - 13 3/4") diameter, 25" tall
HTP ROPES **M:** 4 mm thickness, 25 runners
L: 4 mm thickness, 35 runners
XL: 5 mm thickness, 35 runners
MATERIALS Mahogany Wood (*Swietenia macrophylla*)
 Hand selected goatskin heads
FEATURES Carved from one solid piece of plantation grown Mahogany Wood
 Pre-stretched HTP nylon ropes
 Hand carved shells
 Ornamental carving
ADJ7
 Black coloured hand selected goatskin heads
 Coloured rope wrapping

INCLUDES **ADJ2, ADJ3**
 Professional Djembe Bag made out of heavy-duty padded nylon

COLOURS **ADJ2:** Brown
ADJ3: Brown/Black
ADJ7: Black

PROFESSIONAL, ARTISAN & TONGO CARVED DJEMBES

1 SPECIAL "AFRICAN QUEEN" CARVING 





12" **PROADJ4-L** 10" **PROADJ4-M**

SPECIAL "VILLAGE" CARVING 



12" **PROADJ2-L** 10" **PROADJ2-M**

2 DELUXE CARVING 



14" **PROADJ3-XXL**

3 COLOURED ORNAMENTAL CARVING 



12" **AE-DJTC2-L**

4 

KES-01



5 

DJTH



STANDARD DJEMBE BAGS (SEE PAGE 127)



MSTDJB10 **MSTDJB12**

1 PROFESSIONAL AFRICAN STYLE DJEMBES
SIZES **M:** 10" (9 1/4" - 10 1/4") diameter, 20" tall
L: 12" (10 3/4" - 12 1/4") diameter, 24" tall
HTP ROPES **M:** 4 mm thickness, 25 runners
L: 4 mm thickness, 35 runners
MATERIALS Mahogany Wood (*Swietenia macrophylla*)
 Hand selected goatskin heads
FEATURES Carved from one solid piece of plantation grown Mahogany Wood;
 Pre-stretched HTP nylon ropes
PROADJ2: "Village" carving
PROADJ4: "African Queen" carving
COLOUR Brown

2 ARTISAN EDITION DJEMBE
SIZE 14" (13 3/4" - 15 1/4") diameter, 26" tall
HTP ROPE 5 mm thickness, 40 runners
MATERIALS Mahogany Wood (*Swietenia macrophylla*)
 Hand selected goatskin head

FEATURES Carved from one solid piece of plantation grown Mahogany Wood; Pre-stretched HTP nylon rope; Deluxe carving
COLOUR Brown

3 ARTISAN EDITION TONGO CARVED DJEMBE
SIZE 12" (10 3/4" - 12 1/4") diameter, 24" tall
HTP ROPE 5 mm thickness, 30 runners
MATERIALS Mahogany Wood (*Swietenia macrophylla*)
 Hand selected goatskin head
FEATURES Carved from one solid piece of plantation grown Mahogany Wood; Pre-stretched HTP nylon ropes; Hand carved shell; Coloured ornamental carving
COLOUR Brown

4 KESSING
SIZE Medium
MATERIAL Aluminum

FEATURES Provides a dry rattling accompaniment to the drum; Slides securely into the webbing and is removable

5 DJEMBE TUNING HAMMER
MATERIAL Baltic Birch (*Betula pendula*)
FEATURES Use to tighten the tension on rope tuned djembes; Great for on-the-spot tuning adjustments

6 HEADLINER® SERIES WOOD DJEMBES
SIZE 12 1/2" diameter, 25 1/4" tall
MATERIALS Siam Oak (*Hevea brasiliensis* Muell.-Arg.)
 Hand selected goatskin head
FEATURES 8 mm strong tuning lugs; 2.6 mm rounded rims; Original Meinl style tuning brackets; Black powder coated hardware; Sleek Hourglass shape for more comfort
INCLUDES Tuning key



6 ORIGINAL MEINL STYLE TUNING BRACKETS

Vintage Wine Barrel, 12 1/2" **HDJ500VWB-M**

Natural, 12 1/2" **HDJ500NT**

7 FLOATUNE TUNING AVOIDS THE NEED TO DRILL THROUGH THE SHELL

Gold Amber Sunburst, 12" **DJW3GAB-M**

Natural, 12" **DJW3NT**

8 FLOATUNE TUNING SYSTEM

Zebra Finished Ash, 12" **DJW3ZFA-M**

9 DESIGNER DJEMBE STRAPS

Day of the Dead **MDJS1DA** Kanga Sarong **MDJS1KA** Kenyan Quilt **MDJS1KQ** Pharaoh's Script **MDJS1PS** Simbra **MDJS1SI**

10 PROFESSIONAL SHOULDER STRAP

MDJS2

COLOURS **NT:** Natural, high gloss
VWB-M: Vintage Wine Barrel, matte

7 FLOATUNE SERIES WOOD DJEMBES
SIZE 12" diameter, 24 1/4" tall
MATERIALS Siam Oak (*Hevea brasiliensis* Muell.-Arg.) True Skin Goat Head
FEATURES 8 mm strong tuning lugs; 3 mm rounded SSR-Rims; Easy tuning and comfortable change of heads; Rubber pads and lug placement offer perfect playing comfort; Floatune Tuning System; Chrome plated hardware
INCLUDES Accessory pouch
L-shaped tuning key
Tune Up Oil
COLOURS **GAB-M:** Gold Amber Sunburst, matte
NT: Natural, high gloss

8 FLOATUNE SERIES WOODCRAFT DJEMBE
SIZE 12" diameter, 24 1/4" tall
MATERIALS American White Ash (*Fraxinus americana* L.) True Skin Goat Head
FEATURES 8 mm strong tuning lugs; 3 mm rounded SSR-Rims; Easy tuning and comfortable change of heads; Rubber pads and lug placement offer perfect playing comfort; Floatune Tuning System; Chrome plated hardware
INCLUDES Accessory pouch
L-shaped tuning key
Tune Up Oil
COLOUR Zebra Finished Ash, matte

9 DESIGNER DJEMBE STRAPS
MATERIAL Heavy-duty nylon
FEATURES Holds your djembe in a secure playing position; For standing djembe players; Heavy-duty synthetic fabric that lasts; Adjustable webbed PP straps for a comfortable fit
COLOURS **DA:** Day of the Dead
KA: Kanga Sarong
KQ: Kenyan Quilt
PS: Pharaoh's Script
SI: Simbra

10 PROFESSIONAL SHOULDER STRAP
MATERIAL Heavy-duty nylon
FEATURES Holds any djembe or other drums in perfect playing position; Length adjustable; Adjustable shoulder padding; Quick change hook
COLOUR Black

TAMBOURINES FRAME DRUMS







Tambourines and frame drums are timeless percussion instruments found in cultures around the world, known for their simplicity and expressive sound. The tambourine, with its jingling metal zills, adds a bright, rhythmic shimmer to any musical ensemble, while the frame drum, often featuring a single drumhead, produces deep, resonant tones. Both instruments are incredibly versatile, used in everything from folk and classical music to contemporary styles. Whether you're looking to add a rhythmic accent or a rich, earthy foundation, tambourines and frame drums offer dynamic, hand-played percussion for musicians of all levels.

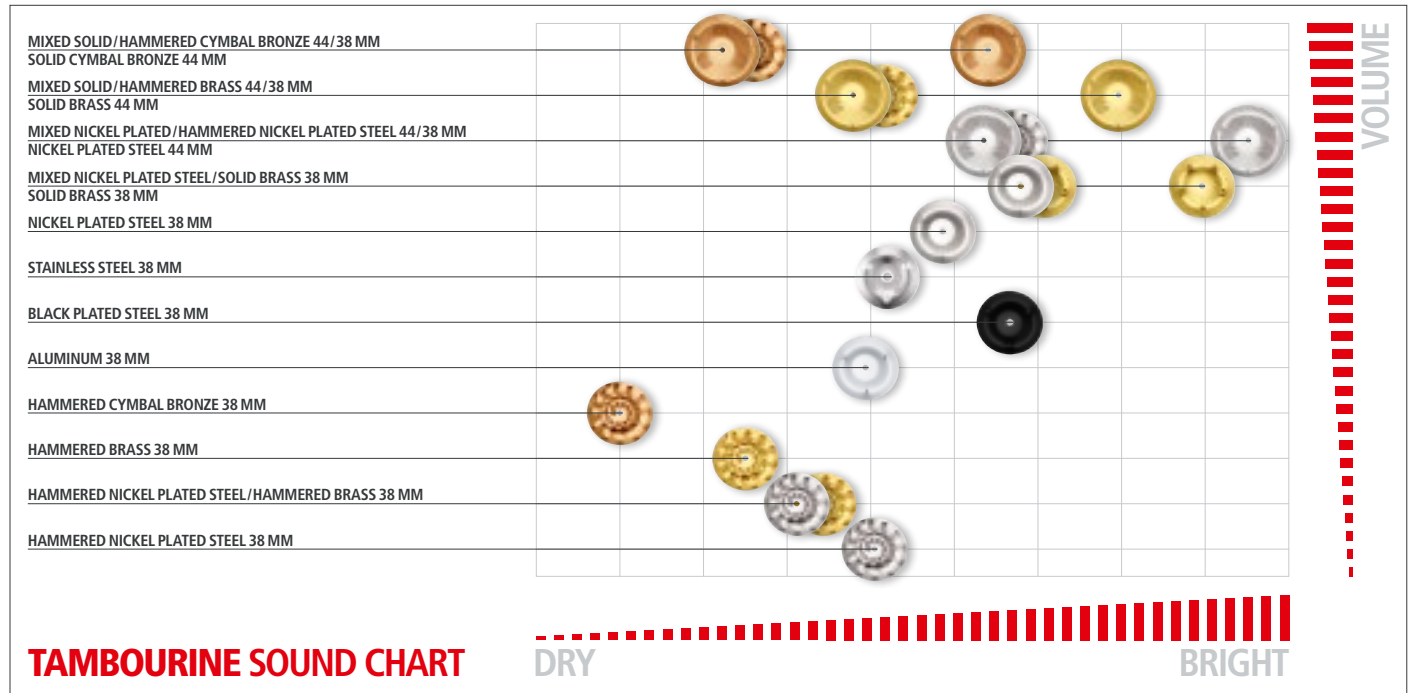



COMPACT WOOD TAMBOURINES



<p>1</p>  <p>3 rows AE-CMTA3BO</p> <p>HAMMERED CYMBAL BRONZE</p>	<p>2</p>  <p>2 rows CTA2B-BK</p> <p>SOLID BRASS</p>	 <p>2 rows CTA2M-BK</p> <p>MIXED NICKEL PLATED STEEL / SOLID BRASS</p>	 <p>2 rows CTA2S-BK</p> <p>NICKEL PLATED STEEL</p>
 <p>3 rows AE-CMTA3B</p> <p>HAMMERED BRASS</p>	 <p>3 rows AE-CATA3S</p> <p>HAMMERED NICKEL PLATED STEEL</p>	 <p>2 rows CTA2VM-WB</p> <p>MIXED HAMMERED NICKEL PLATED STEEL / BRASS</p>	 <p>2 rows CTA2WB</p> <p>STAINLESS STEEL</p>

1 ARTISAN EDITION COMPACT TAMBOURINES

SIZE 8"

MATERIALS **AE-CATA3:** American White Ash (*Fraxinus americana* L.)
AE-CMTA3: Maple (*Adcer* sp.)
B: Hammered brass jingles
BO: Hammered cymbal bronze jingles
S: Hammered nickel plated steel jingles

FEATURES Total unique tambourine sounds; Resounding jingle accents; Special profile jingles; Ergonomic hand grip; Detailed with ornamental heat-branded logo; 3 rows of hammered jingles; Extra narrow jingle slots for precise playing

2 COMPACT WOOD TAMBOURINES

SIZE 8"

MATERIALS Wooden frame
CTA2B-BK: Solid brass jingles
CTA2M-BK: Nickel plated steel / solid brass jingles
CTA2S-BK: Nickel plated steel jingles
CTA2VM-WB: Hammered nickel plated steel / hammered brass jingles
CTA2WB: Stainless steel jingles

FEATURES Compact size; 2 row version

COLOURS **BK:** Black
WB: Walnut Brown

3 ARTISAN EDITION TAMBOURINES

SIZE 10"

MATERIALS **AE-ATA:** American White Ash (*Fraxinus americana* L.)
AE-MTA: Maple (*Adcer* sp.)
B: Solid brass jingles
BO: Solid cymbal bronze jingles
S: Nickel plated steel jingles

FEATURES Total unique tambourine sounds; Resounding tambourine accents; Special profile jingles; Ergonomic hand grip; Detailed with ornamental heat-branded logo; 1 row and 2 row version

WOOD TAMBOURINES



TAMBOURINES

3

1 row
AE-MTA1B0

2 rows
AE-MTA2B0

SOLID CYMBAL
BRONZE 44 MM

AE-MTA1B

1 row
AE-MTA1B

2 rows
AE-MTA2B

SOLID BRASS 44 MM

AE-ATA1S

1 row
AE-ATA1S

2 rows
AE-ATA2S

NICKEL PLATED
STEEL 44 MM

4

1 row
TA1V-WB

2 rows
TA2V-WB

HAMMERED BRASS

TA1B-AB

1 row
TA1B-AB

2 rows
TA2B-AB

SOLID BRASS

TA1AB

1 row
TA1AB

2 rows
TA2AB

NICKEL
PLATED STEEL

TA1VM-WB

1 row
TA1VM-WB

2 rows
TA2VM-WB

MIXED
HAMMERED NICKEL
PLATED STEEL / BRASS

TA1WB

1 row
TA1WB

2 rows
TA2WB

STAINLESS STEEL

TA1A-AB

1 row
TA1A-AB

2 rows
TA2A-AB

ALUMINUM

6

1 row
TA1M-SNT

2 rows
TA2M-SNT

MIXED
NICKEL PLATED
STEEL / SOLID BRASS

7

2 rows
VR-TA2-ROM

4 VINTAGE WOOD TAMBOURINES

SIZE 10"

MATERIALS Wooden frame
TA1V: Hammered brass jingles
TA1VM: Hammered nickel plated steel / hammered brass jingles

FEATURES Legendary tambourine sound; Special profile jingles; Detailed with heat-branded logo; 1 row and 2 row version

COLOUR **WB:** Walnut Brown

5 TRADITIONAL WOOD TAMBOURINES

SIZE 10"

MATERIALS Wooden frame
TA1A-AB, TA2A-AB: Aluminum jingles
TA1B-AB, TA2B-AB: Solid brass jingles
TA1AB, TA2AB: Nickel plated steel jingles
TA1WB, TA2WB: Stainless steel jingles

FEATURES 1 row and 2 row version
TA1WB, TA2WB: Detailed with heat-branded logo

COLOURS **AB:** Antique Brown
WB: Walnut Brown

6 RECORDING-COMBO WOOD TAMBOURINES

SIZE 10"

MATERIALS Wooden frame
 Nickel plated steel / solid brass jingles

FEATURES Dual-alloy jingles; 1 row and 2 row version

COLOUR **SNT:** Super Natural

7 WOOD TAMBOURINE

SIZE 10"

MATERIALS Black plated steel jingles
 Siam Oak (*Hevea brasiliensis* Muell.-Arg.)

FEATURES Double row; Ergonomic grip

FINISH Red/orange marble

HEADED WOOD TAMBOURINES



1 HEADED ARTISAN EDITION TAMBOURINES

SIZE 10"

MATERIALS Hand selected calfskin heads
AE-ATAH: American White Ash (*Fraxinus americana* L.)
AE-MTAH: Maple (*Adcer sp.*)
B: Solid / hammered brass jingles
BO: Solid / hammered cymbal bronze jingles
S: Nickel plated / hammered nickel plated steel jingles

FEATURES Total unique tambourine sounds; Resounding jingle accents; Two different profile jingles; Ergonomic hand grip; Detailed with ornamental heat-branded logo; Prepared with Resin

2 TAMBURELLO

SIZE 12"

MATERIALS Wooden frame; Hand selected goatskin head; Aluminum jingles

FEATURES 2 row version; Detailed with heat-branded logo; Total unique tambourine sounds

3 VINTAGE GOATSKIN WOOD TAMBOURINES

SIZE 10"

MATERIALS Wooden frame; Hand selected goatskin heads; Hammered brass jingles

FEATURES 1 row and 2 row version; Detailed with heat-branded logo

COLOUR **WB:** Walnut Brown

4 TOURING SYNTHETIC HEAD WOOD TAMBOURINES

SIZE 10"

MATERIALS Wooden frame; True Feel synthetic heads; Black plated steel jingles

FEATURE 1 row and 2 row version
COLOUR **R:** Red

5 RECORDING-COMBO GOATSKIN WOOD TAMBOURINES

SIZE 10"

MATERIALS Wooden frame; Hand selected goatskin heads; Nickel plated steel / solid brass jingles

FEATURES Dual-alloy jingles; 1 row and 2 row version

COLOUR **SNT:** Super Natural

6 TRADITIONAL GOATSKIN WOOD TAMBOURINES

SIZE 10"

MATERIALS Wooden frame; Hand selected goatskin heads
TAH1A-AB, TAH2A-AB: Aluminum jingles

HAND HELD ABS TAMBOURINES



TAMBOURINES

7

1 row, 8"
HTT8BK

2 rows, 10"
HTT10BK

1 row, 8"
HTT8R

2 rows, 10"
HTT10R

1 row, 8"
HTT8WH

2 rows, 10"
HTT10WH

STAINLESS STEEL

8

1 row
HTBK

2 rows
HTMT1BK

1 row
HTR

2 rows
HTMT1R

1 row
HTWH

2 rows
HTMT1WH

STAINLESS STEEL

9

2 rows
TMT1B-BK

SOLID BRASS

2 rows
TMT1BK

NICKEL PLATED STEEL

2 rows
TMT1R

NICKEL PLATED STEEL

2 rows
TMT1A-B

ALUMINUM

10

2 rows
TMT1M-BK

MIXED NICKEL PLATED STEEL / SOLID BRASS

2 rows
TMT1M-WH

TAH1B-AB, TAH2B-AB:

Solid brass jingles

TAH1AB, TAH2AB:

Nickel plated steel jingles

TAH1WB, TAH2WB:

Stainless steel jingles

FEATURES 1 row and 2 row version

TAH1WB, TAH2WB: Detailed with heat-branded logo

COLOURS **AB:** Antique Brown

WB: Walnut Brown

7 HEADLINER® SERIES TOUR TAMBOURINES

SIZES **HTT8:** 8"
HTT10: 10"

MATERIALS Molded ABS; Stainless steel jingles

FEATURES Handheld; Extra wide grip; Bright, cutting sound; Durable frame

HTT8: 1 row version; Compact size

HTT10: 2 row version

COLOURS **BK:** Black

R: Red

WH: White

8 HEADLINER® SERIES HAND HELD ABS TAMBOURINES

MATERIALS Molded ABS; Stainless steel jingles

FEATURES Ergonomic hand grip for more playing comfort; Güiro style playing surface; Penetrating jingle sound

HT: 1 row version

HTMT1: 2 row version

COLOURS **BK:** Black

R: Red

WH: White

9 TRADITIONAL HAND HELD ABS TAMBOURINES

MATERIALS Molded ABS

TMT1A-B: Aluminum jingles

TMT1B-BK: Solid brass jingles

TMT1BK, TMT1R: Nickel plated steel jingles

FEATURES Padded soft grip for more playing comfort; Ergonomic design; Güiro style playing surface; "Sandwich" construction

COLOURS **B:** Blue

BK: Black

R: Red

10 RECORDING-COMBO HAND HELD ABS TAMBOURINES

MATERIALS Molded ABS; Nickel plated steel / solid brass jingles

FEATURES Padded soft grip for more playing comfort; Ergonomic design; Güiro style playing surface; "Sandwich" construction

COLOURS **BK:** Black

WH: White

MOUNTABLE ABS TAMBOURINES

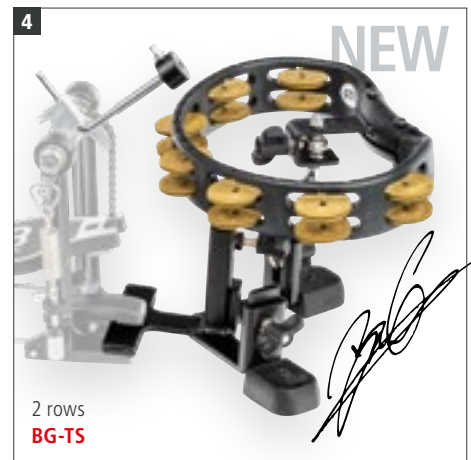
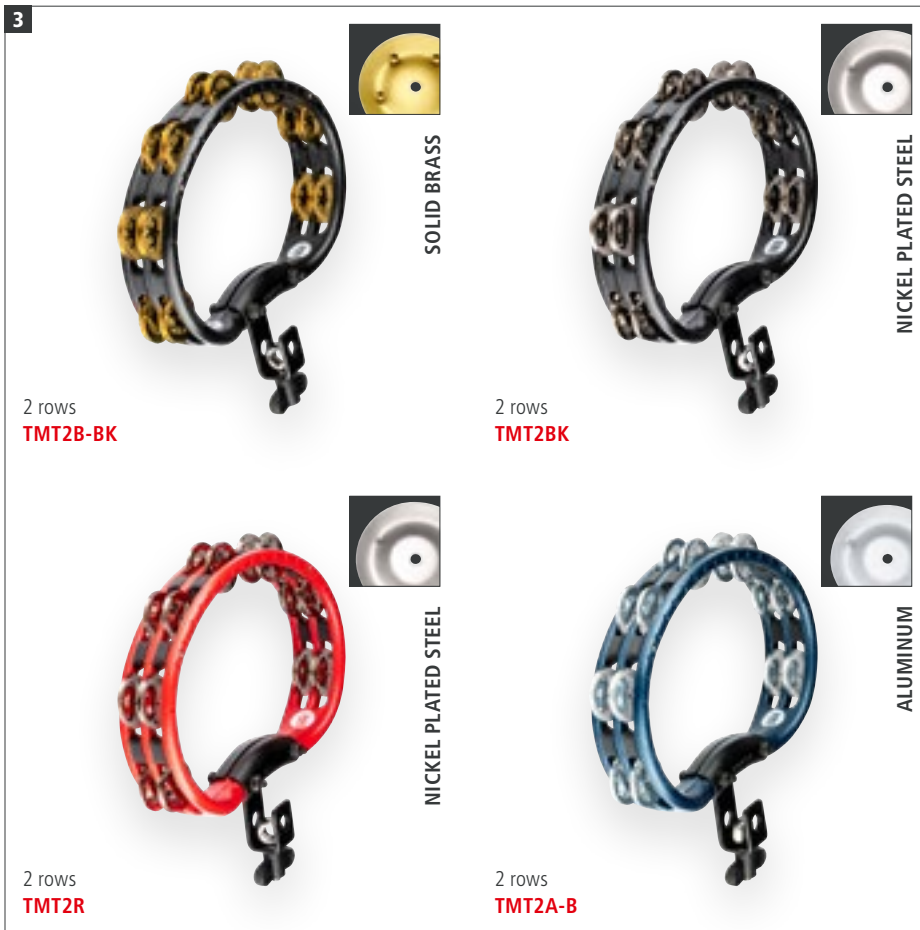
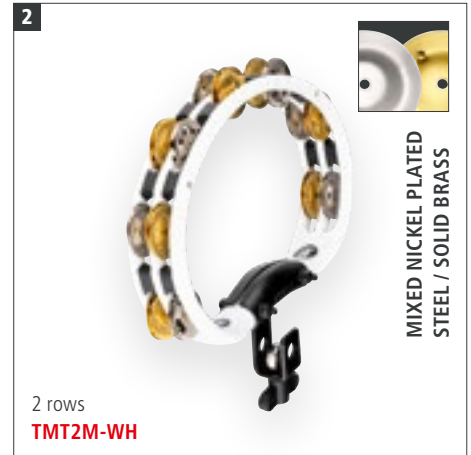

1 HEADLINER® SERIES MOUNTABLE ABS TAMBOURINES

- MATERIALS** Molded ABS
Stainless steel jingles
- FEATURES** Easy mountable
Güiro style playing surface
Penetrating jingle sound
- COLOURS** **BK:** Black
R: Red
WH: White

2 RECORDING-COMBO MOUNTABLE ABS TAMBOURINE

- MATERIALS** Molded ABS
Nickel plated steel / solid brass jingles
- FEATURES** Easily mountable
Ergonomic design
Güiro style playing surface
"Sandwich" construction
- COLOUR** **WH:** White

3 TRADITIONAL MOUNTABLE ABS TAMBOURINES

- MATERIALS** Molded ABS
TMT2A-B: Aluminum jingles
TMT2B-BK: Solid brass jingles
TMT2BK, TMT2R: Nickel plated steel jingles
- FEATURES** Easily mountable
Ergonomic design
Güiro style playing surface
"Sandwich" construction
- COLOURS** **B:** Blue
BK: Black
R: Red

4 BENNY GREB SIGNATURE TAMBOSTEP

- MATERIAL** Sand blasted brass jingles
- FEATURES** Designed with Benny Greb
Hands-free tambourine
Great for multi-instrumentalists, guitarists, and cajon players
- INCLUDES** Pedal Mount (PM-1); Special designed Z-shaped rod and beater

CHING RINGS & HIHAT TAMBOURINES



TAMBOURINES

1



Ching Ring
CRING



Dry Ching Ring
DCRING



Soft Ching Ring
SCRING

2



SFHHT

3



1 row
HTHH1B-BK



2 rows
HTHH2B-BK

4



1 row
THH1B-BK



1 row
HTHH1BK



2 rows
HTHH2BK

4



1 row
THH1BK

5



1 row
HTHHBG

SAND HIHAT TAMBOURINE
DESIGNED WITH BENNY GREB

6

NEW



TMTH

1 CHING RINGS

SIZE 6"
MATERIALS **CRING**
 Steel ring
 5 pairs of stainless steel jingles
DCRING
 Steel ring
 5 pairs of zinc jingles
SCRING
 Foam ring
 6 pairs of stainless steel jingles
FEATURES
 Fits on most cymbals
 Quick setup

2 SUPER FLEX HIHAT TAMBOURINE

SIZE 4.3" inner diameter, 9.5" outer diameter
MATERIALS Mylar frame
 10 pairs of stainless steel jingles
FEATURES Super flex frame produces enhanced hihat tambourine accents

10 pairs of stainless steel jingles deliver a clear and bright sound
 Extra-wide 9.5" shape gives you outstanding foot response
 Shines through the mix to easily blend a tambourine effect into your grooves

3 HEADLINER® SERIES HIHAT TAMBOURINES

SIZE 5"
MATERIALS **HTHH1BK, HTHH2BK:**
 Stainless steel jingles
HTHH1B-BK, HTHH2B-BK:
 Hammered brass jingles
FEATURE 1 row and 2 row version

4 PROFESSIONAL SERIES HIHAT TAMBOURINES

SIZE 5"
MATERIALS **THH1BK:** Stainless steel jingles
THH1B-BK: Solid brass jingles

FEATURE Rubber padded surface

5 BENNY GREB SAND HIHAT TAMBOURINE

SIZE 5"
MATERIAL Sand blasted brass jingles
FEATURES Benny Greb signature hihat tambourine
 Eight pairs of sand blasted brass jingles
 Dry, vintage sound with unique matte appearance
 Blends easily into your natural drum set or percussion mix
 Wing nut design fits on any hihat rod

6 TAMBOURINE HIHAT

SIZE 5"
MATERIAL Stainless steel jingles
FEATURES Top and bottom pieces work like hihats
 Great for low volume kits
 Sturdy steel frame

1

Synthetic head, 8 3/4"
AERIQ1

2

CHROME PLATED STEEL JINGLES

Clear Mylar head, 10"
PA10ABS-BK

Napa head, 10"
PA10ABS-BK-NH

3

CHROME PLATED STEEL JINGLES

Poplar Wood, 10"
PA10PW-M

Siam Oak, 10"
PA10CN-M

4

HAND-HAMMERED BRASS JINGLES

Goatskin head, 10"
PA10AB-M



Siam Oak, 12"
PA12CN-M

5

UNIQUE SHAKER PODS

Napa head, 10"
PAS10PW-NH

6

EASY MOUNTABLE

Napa head, 10"
PA10A-BK-NH-H

1 ARTISAN EDITION RIQ DRUM

SIZE 8 3/4"
MATERIALS Wooden frame; Synthetic head; Ten pairs of brass jingles
FEATURES Artisan sounds for Arabic folk and classical music; Five tuning lugs
INCLUDES Tuning key; Bag
FINISH White Pearl Mosaic Royale

2 TRADITIONAL ABS PANDEIROS

SIZE 10"
MATERIALS Molded ABS; Chrome plated steel jingles
PA10ABS-BK
Replaceable synthetic head
PA10ABS-BK-NH
Replaceable Napa head
FEATURES Countersunk bolt lugs
PA10ABS-BK: Logo applied from underneath the head (CN, TH, US patent)
PA10ABS-BK-NH: Reduced overtones

INCLUDES Tuning key
COLOUR **BK**: Black

3 TRADITIONAL WOOD PANDEIROS

SIZES **PA10**: 10"
PA12: 12"
MATERIALS Replaceable hand selected goatskin head; Chrome plated steel jingles
PA10CN-M, PA12CN-M
Siam Oak (*Hevea brasiliensis* Muell.-Arg.)
PA10PW-M
Poplar Wood (*Populus*)

INCLUDES Tuning key
COLOUR **CN-M**: Chestnut, matte

4 SHELL-TUNED PANDEIRO

SIZE 10"
MATERIALS Siam Oak (*Hevea brasiliensis* Muell.-Arg.)
Hand selected goatskin head;
Hand-hammered brass jingles

INCLUDES Hex key
COLOUR **AB-M**: Antique Brown, matte

5 SHAKER PANDEIRO

SIZE 10"
MATERIALS Poplar Wood (*Populus*); Replaceable Napa head; Aluminum shaker pods
FEATURE Countersunk bolt lugs
INCLUDES Tuning key

6 TRADITIONAL ABS PANDEIRO WITH HOLDER

SIZE 10"
MATERIALS Molded ABS; Replaceable Napa head; Chrome plated steel jingles
FEATURES Countersunk bolt lugs; Reduced overtones; Easy mountable
INCLUDES Tuning key
COLOUR **BK**: Black

FRAME DRUMS



1 HAND DRUMS

SIZES **HD10:** 10"; **HD12:** 12"; **HD14:** 14"; **HD16:** 16"; **HD18:** 18"; **HD20:** 20"; **HD22:** 22"

MATERIALS Siam Oak (*Hevea brasiliensis* Muell.-Arg.)
AB: Hand selected goatskin head
AB-TF: True Feel synthetic head

COLOUR Antique Brown

2 TARS

SIZES **FD16:** 16", 2 1/2" deep
FD18: 18", 2 1/2" deep
FD20: 20", 2 1/2" deep
FD22: 22", 2 1/2" deep

MATERIALS Siam Oak (*Hevea brasiliensis* Muell.-Arg.)
T: Hand selected goatskin head
T-TF: True Feel synthetic head

FEATURE Internal tuning system

INCLUDES Hex key

COLOUR Antique Brown, matte

3 ARTISAN EDITION TARS (PATENTED)

SIZES **AE-FD14:** 14", 2 1/2" deep
AE-FD18: 18", 2 1/2" deep
AE-FD22: 22", 2 1/2" deep

MATERIALS Siam Oak (*Hevea brasiliensis* Muell.-Arg.)
Hand selected goatskin head

FEATURES Special designed bearing edge (DE, US patent); Internal tuning system

INCLUDES Hex key

COLOUR Walnut Brown, matte

4 SEA DRUMS

SIZES **FD16:** 16", 2 3/4" deep
FD18: 18", 2 3/4" deep
FD20: 20", 2 3/4" deep
FD22: 22", 2 3/4" deep

MATERIALS Siam Oak (*Hevea brasiliensis* Muell.-Arg.)
Transparent synthetic head and
SD: Hand selected goatskin head
SD-TF: True Feel synthetic head

FEATURES Steel balls inside; Sealable filling port

COLOUR Antique Brown, matte

5 MIZHARS

SIZES **FD12:** 12", 4" deep; **FD14:** 14", 4" deep; **FD18:** 18", 4" deep

MATERIALS Siam Oak (*Hevea brasiliensis* Muell.-Arg.)
T-D: Hand selected goatskin head
T-D-TF: True Feel synthetic head

FEATURES Deep shell construction for full sound development; Internal tuning system

INCLUDES Hex key

COLOUR Brown Burl, matte

6 ARTISAN EDITION MIZHARS (PATENTED)

SIZES **AE-FD14:** 14", 4" deep
AE-FD18: 18", 4" deep
AE-FD22: 22", 4" deep

MATERIALS Siam Oak (*Hevea brasiliensis* Muell.-Arg.)
Hand selected goatskin head

5 **HAND SELECTED GOATSKIN HEAD**

18" x 4" **FD18T-D**
14" x 4" **FD14T-D**
12" x 4" **FD12T-D**

TRUE FEEL SYNTHETIC HEADS

18" x 4" **FD18T-D-TF**
14" x 4" **FD14T-D-TF**
12" x 4" **FD12T-D-TF**

6

22" x 4" **AE-FD22T-D**
18" x 4" **AE-FD18T-D**
14" x 4" **AE-FD14T-D**

7 **HAND SELECTED GOATSKIN HEAD**

16" x 2 1/2" **FD16BE**
14" x 4" **FD14BE**
12" x 4" **FD12BE**

TRUE FEEL SYNTHETIC HEADS

16" x 2 1/2" **FD16BE-TF**
14" x 4" **FD14BE-TF**
12" x 4" **FD12BE-TF**

8 **METAL RINGS FOR SPECIAL EFFECTS**

20" x 2 1/2" **FD20D-TF**
20" x 2 1/2" **FD20D-WH**

9 **CROSS BAR**

18" x 4" **FD18B0**

10 **DAMPENING LAYER FOR LESS OVERTONES**

14" x 6" **FD14IB0**

11

7 1/2" **FD7KA**

12

15" **HOD15**
12 1/2" **HOD125**

13

Set, 4 pcs. **PL-SET**

FEATURES Special designed bearing edge (DE, US patent); Internal tuning system
INCLUDES Hex key
COLOUR Walnut Brown, matte

7 BENDIRS

SIZES **FD12:** 12", 4" deep; **FD14:** 14", 4" deep; **FD16:** 16", 2 1/2" deep
MATERIALS Siam Oak (*Hevea brasiliensis* Muell.-Arg.)
BE: Hand selected goatskin head
BE-TF: True Feel synthetic head
FEATURES Internal tuning system; Buzzing effect
INCLUDES Hex key
COLOUR Antique Brown, matte

8 DAFS

SIZE 20", 2 1/2" deep
MATERIALS Siam Oak (*Hevea brasiliensis* Muell.-Arg.)
FD20D-TF: True Feel synthetic head
FD20D-WH: Woven synthetic head

FEATURE Metal rings for special effects
COLOUR Antique Brown, matte

BODHRANS 9 10

MATERIALS Siam Oak (*Hevea brasiliensis* Muell.-Arg.)
INCLUDES Hand selected goatskin head
INCLUDES Hex key

9 CELTIC BODHRAN

SIZE 18", 4" deep
FEATURES Cross bar; Internal tuning system
COLOUR Antique Brown, matte

10 IRISH BODHRAN

SIZE 14", 6" deep
FEATURES Extra deep shell for full sound development; Dampening layer around rim for reduced overtones
COLOUR Brown Burl, matte

11 KANJIRA

SIZE 7 1/2", 2 1/4" deep
MATERIALS Siam Oak (*Hevea brasiliensis* Muell.-Arg.)
FEATURES Hand selected goatskin head
INCLUDES Many sound options; Set of 3 jingles
COLOUR Hex key
COLOUR Antique Brown, matte

12 NATIVE AMERICAN-STYLE HOOP DRUMS

SIZES **HOD125:** 12 1/2"; **HOD15:** 15"
MATERIALS Hand selected buffalo head
FEATURE Nylon lacing and grip
INCLUDES Warm and powerful sound
Leather padded wooden beater

13 PLENERA SET

SIZES 8" Quinto; 10" Seguidor; 12" Tumbador
MATERIALS ABS molded frames; Goatskin heads
FEATURE External mechanical lug tuning
INCLUDES Nylon Bag; Tuning Key



HAND PERCUSSION



Hand percussion instruments like shakers, kalimbas, and castanets, chimes and many more instruments bring subtle yet essential rhythms to a wide range of musical styles. These small, easy-to-play instruments offer a delicate and precise way to enhance the groove, adding texture and colour to your sound. From the crisp shake of a maraca to the sharp click of claves, hand percussion creates dynamic layers that enrich both live performances and studio recordings. Whether you're a seasoned percussionist or a beginner, these instruments are perfect for adding a rhythmic pulse and driving the energy of any musical piece.

SHAKERS & TAMBOURINES

<p>1</p> <p>SOFT: STUDIO</p>  <p>Studio shaker, Red SH5R</p> <p>72 - 76 DB</p>	<p>MEDIUM: LIVE</p>  <p>Live shaker, Black SH4BK</p> <p>79 - 81 DB</p>	<p>MEDIUM: LIVE</p>  <p>Live shaker, Creamsicle SH4CS</p>	<p>MEDIUM: LIVE</p>  <p>Live shaker, Electric Coral SH4EC</p>
<p>MEDIUM: LIVE</p>  <p>Live shaker, Glacier Blue SH4GB</p>	<p>MEDIUM: LIVE</p>  <p>Live shaker, Seafoam Green SH4SF</p>	<p>MEDIUM: LIVE</p>  <p>Live shaker, White SH4WH</p>	<p>LOUD: STADIUM</p>  <p>Stadium shaker, Grey SH45GR</p> <p>88 - 93 DB</p>

2



MSS

3



Set, 3 pcs.
PP-1

4

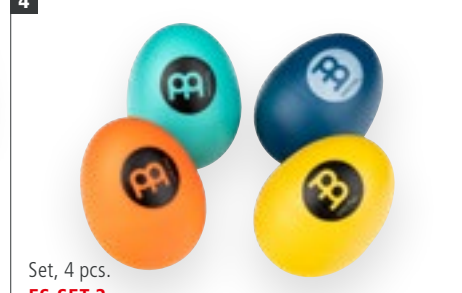

Set, 4 pcs.
ES-SET-2

5

SOFT

MEDIUM

LOUD

EXTRA LOUD



Set, 4 pcs.
ES-SET

6

COMES IN A SET OF TWO

Black **ES2-BK**

Red **ES2-R**

Blue **ES2-B**

Yellow **ES2-Y**

Green **ES2-GREEN**



1 ARTIST SERIES SHAKERS LUIS CONTE

SIZE Medium

MATERIAL Synthetic

FEATURES Two individual shakers connected as one instrument

SH4: Perfect for live playing

SH45: Perfect for stadium situations

SH5: Perfect for studio recordings

COLOURS

BK: Black

CS: Creamsicle

EC: Electric Coral

GB: Glacier Blue

GR: Grey

R: Red

SF: Seafoam Green

WH: White

2 LUIS CONTE SHAKER WITH STRAPS

SIZE Medium

MATERIAL Synthetic

FEATURES Strap to a drumstick to get shaker sounds as you play

Add new sonic layers to your drum set grooves

COLOUR **BK:** Black

INCLUDES Two durable rubber straps

3 PERC PACK

CONTAINS Compact Foot Tambourine

Luis Conte Live Shaker

Classic Wood Claves

FEATURES Compact Foot Tambourine for hands free use

Luis Conte Live Shaker for smooth sound

Classic Wood Claves for traditional rhythms

4 EGG SHAKER ASSORTMENT

MATERIAL Synthetic

FEATURES Four-piece egg shaker set ideal for any percussion set up

Designed for four different volume levels

Colour coded for easy identification

Easily transportable

5 EGG SHAKER SET

MATERIAL Synthetic

FEATURE Range of volume from soft to extra loud

6 EGG SHAKER PAIRS

MATERIAL Synthetic

FEATURE Comes in a set of two

COLOURS

B: Blue

BK: Black

GREEN: Green

R: Red

Y: Yellow

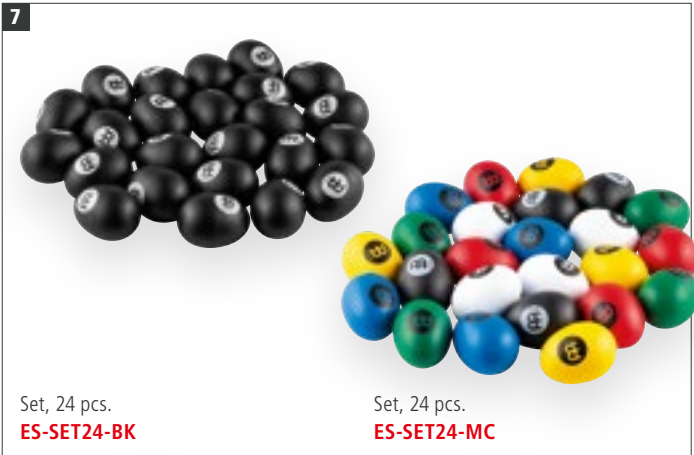

Set, 24 pcs.
ES-SET24-BK

Set, 24 pcs.
ES-SET24-MC



Set, 60 pcs.
ES-BOX



Happy Face
FACE-H

Laughing Face
FACE-L

Poop Face
FACE-P

Sad Face
FACE-S



Face Shaker Assortment, 24 pcs.
FSA1

Face Shaker Assortment, 4 pcs.
FSA4



Key Ring Tambourine, Red
KRT-R

Key Ring Tambourine, Black
KRT-BK

Key Ring Shaker and Tambourine Assortment
KRA1

Key Ring Shaker, Grey
KRS-GR

Key Ring Shaker, Black
KRS-BK

7 EGG SHAKER SETS OF 24 PCS.
MATERIAL Synthetic
FEATURES Crystal clear shaker sounds
 Durable shells
 Great for group or classroom percussion
COLOURS **BK:** Black
MC: Multi-colour

8 EGG SHAKER BOX
CONTAINS Holds 60 Egg Shakers:
 20 x Egg Shaker, Blue (B)
 10 x Egg Shaker, Black (BK)
 10 x Egg Shaker, Green (GREEN)
 10 x Egg Shaker, Red (R)
 10 x Egg Shaker, Yellow (Y)

9 FACE SHAKERS
MATERIAL Molded ABS
CONTAINS **FSA1**
 6 x Happy Face
 6 x Laughing Face
 6 x Poop Face
 6 x Sad Face
FSA4
 1 x Happy Face
 1 x Laughing Face
 1 x Poop Face
 1 x Sad Face
FEATURES Made of durable molded ABS
 Loud filling projects clearly
 Great accent for live and studio applications
INCLUDES **FSA1:** Fishbowl

GRAPHICS **FACE-H:** Happy Face
FACE-L: Laughing Face
FACE-P: Poop Face
FACE-S: Sad Face

10 KEY RING SHAKERS & KEY RING TAMBOURINES
MATERIALS Molded ABS
KRT: Nickel plated steel
CONTAINS **KRA1**
 10 x Key Ring Shaker
 8 x Key Ring Tambourine
FEATURES Easily detach when it's time to play
 Perfect for acoustic shows or jam sessions
INCLUDES **KRA1:** Fishbowl
FINISHES **BK:** Black
GR: Grey
R: Red

SHAKERS

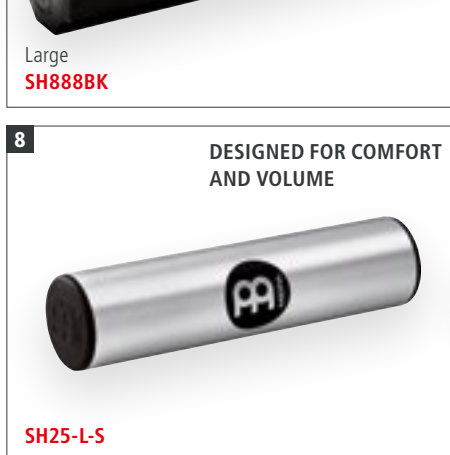

1 STUDIO SHAKERS

SIZES **SH10-M-BK**: Medium
SH10-L-BK: Large

MATERIAL Synthetic

FEATURE Deliver a very tasteful and delicate shaker sound with a warm tone and well balanced frequency spectrum

COLOUR **BK**: Black

2 STUDIOMIX SHAKERS

SIZES **SH12-M-BK**: Medium
SH12-L-BK: Large

MATERIAL Synthetic

FEATURE Textured surface for special sound and positive grip

COLOUR **BK**: Black

3 CRYSTAL SHAKERS

SIZE Large

MATERIALS Synthetic; Acrylic

FEATURES Shapes any groove with clarity and feel
SH26-L-L: Perfect for live playing
SH26-L-S: Perfect for studio recordings

4 FIBERGLASS SHAKER

SIZE Large

MATERIAL Premium fiberglass

FEATURE Made from premium fiberglass for more durability and better sound quality

COLOUR **BK**: Black

5 ALUMINUM SHAKERS, OCTAGONAL

SIZES **SH8BK**: Small
SH88BK: Medium
SH888BK: Large

MATERIAL Aluminum

FEATURE Provides a broad dynamic range with lots of volume

COLOUR **BK**: Black

6 ALUMINUM JINGLE SHAKER

SIZE Medium

MATERIALS Shaker: Aluminum
Jingles: Steel

FEATURE Two pairs of steel jingles are attached in one row to an octagonal aluminum shaker

COLOUR **BK**: Black

7 ALUMINUM SHAKER, ROUND

SIZE Large

MATERIAL Anodized aluminum

FEATURE Designed to cut through loud live music

COLOUR **S**: Silver

8 PROJECTION SHAKER

SIZE Large

MATERIAL Anodized aluminum

FEATURES For comfort and volume; Shimmering, cutting pitch; Exceptional for live playing

COLOUR **S**: Silver

10 CIRCULAR MOTION ENABLES A UNIQUE RATTLING



Spark shaker
SH16

SENSATIONAL EFFECTS ARE PRODUCED WHEN COMBINED WITH ANOTHER SPARK SHAKER



11 SCREW-MOUNTED DISC ENABLES A TUNABLE PITCH



Spin spark
SH17

12



Headed spark
SH18

MOTION SHAKER
(SEE PAGE 55)



MS-BK

13



Medium
SH20BK

BY COVERING AND UNCOVERING THE SOUND HOLE, A "WAH-WAH" EFFECT CAN BE ACHIEVED

14 LOUD AND PENETRATING SOUND DUE TO THE MANY HOLES



SH3BK

15



Black
SH21BK

9 PROTON SHAKER
MATERIAL Aluminum
FEATURES Compact size; Easy to control; Made for precise playing techniques

10 ORIGINAL SPARK SHAKER
SIZE Medium
MATERIALS Shaker: Coated steel
 Pellets: Coated steel
FEATURES Circular motion enables a unique rattling; Spark Shakers may be played in pairs
FINISH Black nickel

11 SPIN SPARK SHAKER
SIZE Medium
MATERIALS Shaker: Coated steel
 Pellets: Coated steel
FEATURE Screw-mounted disc enables a tunable pitch
FINISH Black nickel

12 HEADED SPARK SHAKER
SIZE Medium
MATERIALS Shaker: Coated steel
 Pellets: Coated steel
 Goatskin head
FEATURES Premium goatskin and a steel shell provide a rattling combination; Swirling effect; Variable pitch
FINISH Black nickel

13 WAKAH SHAKER
SIZE Medium
MATERIALS Wooden body and synthetic chamber
FEATURE By covering and uncovering the sound hole, a "wah-wah" effect can be achieved
COLOUR **BK:** Black

14 LOOP SHAKER
SIZE Medium
MATERIAL Synthetic
FEATURE Loud and penetrating sound due to the many holes
COLOUR **BK:** Black

15 U.F.O. SHAKER
SIZE Medium
MATERIAL Synthetic
COLOUR **BK:** Black

SHAKERS

1



Baltic Birch
SH50

Ovangkol
SH51

CUTTING SHAKER SOUND

2



Set, 3 pcs.
SH50-SET

DIFFERENT FILLINGS

3

EXOTIC ZEBRANO TOP AND BOTTOM



Small
SH53-S

Medium
SH53-M

4



Burl Wood
SH60

DUAL INTERNAL CHAMBERS

5

SOFT



Lime
SH56

MEDIUM



Beech
SH58

LOUD



Oak
SH59

6



Double Shaker
D01

Ganza
GA2

7



Small
CAX1

Medium
CAX2

Large
CAX3

1 MINI CAJON SHAKERS

SIZE 2" W x 2 3/4" H x 2" D

MATERIALS Resonating body: Baltic Birch (*Betula pendula*)
SH50
Frontplate: Baltic Birch (*Betula pendula*)
SH51
Frontplate: Ovangkol (*Guibourtia ehie*)

FEATURES Compact size; Cutting shaker sound; Miniature size of a Meinl cajon

2 MINI CAJON SHAKER SET

MATERIALS Resonating body: Baltic Birch (*Betula pendula*)
Frontplates: Exotic Zebrano, Burl Wood, Baltic Birch (*Betula pendula*)

FEATURES Three unique timbres for multiple sound options; Various frontplates for easy identification

3 WOOD SHAKERS, RECTANGLE

SIZES **S:** Small
M: Medium

MATERIALS Baltic Birch (*Betula pendula*)
Top and Bottom: Exotic Zebrano

FEATURES Wide sound options; Rectangle shaped

4 DUAL CHAMBER SHAKER

MATERIAL Baltic Birch Plywood (*Betula pendula*)
Top and Bottom: Burl Wood

FEATURES Dual internal chambers for greater shaker control; Easier to play consistent shaker patterns; Ultra-smooth sound

5 WOOD SHAKERS, ROUND

SIZE 4" length, 1 3/4" diameter

MATERIALS **SH56:** Lime
SH58: Beech
SH59: Oak

FEATURES Made from three wood species for different volume; Fits comfortably in your hand
SH56: Soft
SH58: Medium
SH59: Loud

6 DOUBLE SHAKER & GANZA

MATERIALS Rattan with coconut bottom

FEATURES **D01:** Offers two different sounds in one instrument
GA2: Crystal clear sound, high pitched with a great projection

7 CAXIXIS

SIZES **CAX1:** Small
CAX2: Medium
CAX3: Large

MATERIALS Rattan with coconut bottom

FEATURES Crystal clear sound, high pitched with a great projection; Woven by hand

KALIMBAS & CASTANETS



Small
KA5-S

Medium
KA9-M

Medium
KA7-M-BK



WIDE OPENING FOR GREAT WAH-WAH EFFECTS

KA9WW-BK

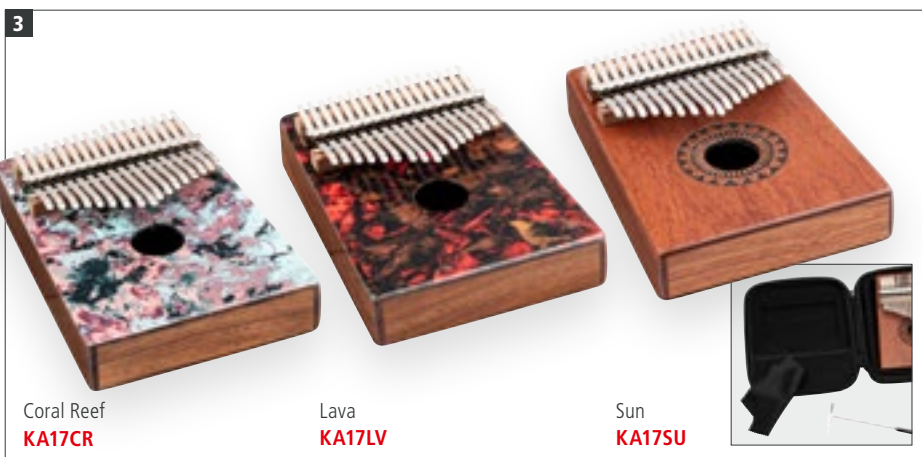

Coral Reef
KA17CR

Lava
KA17LV

Sun
KA17SU



BUILT-IN PICKUP

PKA17AW



SEPARATELY ADJUSTABLE

CM2

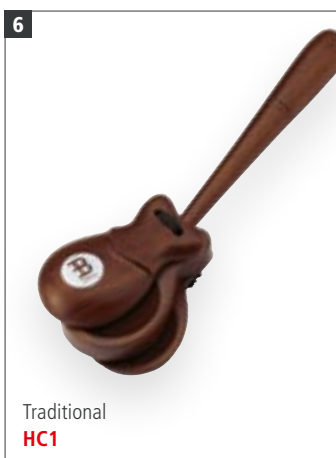

Traditional
HC1



Traditional
FC1

Concert
FC2

1 SOLID KALIMBAS
SIZES **KA5-S**: Small
KA7-M-BK, KA9-M: Medium
MATERIALS New Zealand Pine (*Pinus radiata*)
TUNING **KA5-S**: g#, c', f', f', c'''
KA7-M-BK: e', g, d'', e, c', a, a'
KA9-M: a', c', c', a', A, f', e', e'', b'
FEATURES **KA5-S, KA9-M**: Heat-branded logo
KA7-M-BK: Extra wide tongues

2 WAH-WAH KALIMBA
MATERIALS New Zealand Pine (*Pinus radiata*)
TUNING a', c', c', a', A, f', e', e'', b'
COLOUR **BK**: Black

3 SOUND HOLE DESIGNER KALIMBAS
MATERIALS **KA17CR, KA17LV**: Acacia
KA17SU: Sapele
TUNING C Major: d'', b', g', e', c', a, f, d, c, e, g, b, d', f', a', c'', e'' (17 notes)
FEATURES Easy for all skill levels
INCLUDES Travel case; Microfiber cleaning cloth; Tuning hammer
DESIGNS **CR**: Coral Reef; **LV**: Lava; **SU**: Sun

4 SOLID PICKUP KALIMBA
MATERIALS American Walnut
TUNING C Major: d'', b', g', e', c', a, f, d, c, e, g, b, d', f', a', c'', e'' (17 notes)
FEATURES Easy for all skill levels; Built-in pickup
INCLUDES Travel case; Microfiber cleaning cloth; Tuning hammer

5 CASTANET MACHINE
SIZE 7 1/2" x 5"
MATERIAL Indian Rosewood
FEATURES Separately adjustable; Full and cutting resonance

6 TRADITIONAL HAND CASTANET
SIZE Traditional
MATERIAL Indian Rosewood

7 FINGER CASTANETS
SIZES **FC1**: Traditional
FC2: Concert
MATERIAL Indian Rosewood

SOUND EFFECTS

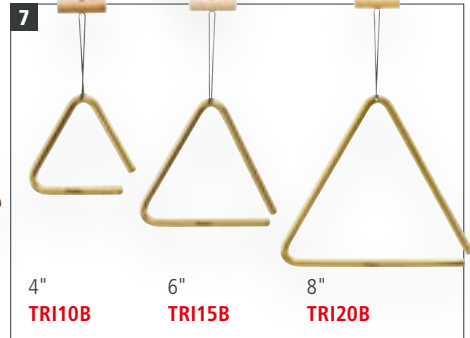

1 BIRDS & WATERFALLS

MATERIALS **B17RY, WA7BK:** Premium fiberglass
B11NT, WA1NT, B12NT, WA2NT: Siam Oak (*Hevea brasiliensis* Muell.-Arg.)
FEATURES Durable cord
BI: Realistically imitate the sound of a flock of birds; Bright sound with big dynamic range
WA: Realistically imitate the sound of a rippling waterfall
COLOURS **BK:** Black
NT: Natural
RY: Red/Yellow

2 AJUCH BELLS

SIZES 30" long
MABS: Small bells
MABM: Medium bells
MABL: Large bells
MATERIAL Brass and synthetic wax

FEATURES Cast bells; Solid hook for easy attachment; Synthetic wax rope
INCLUDES Canvas pouch for safe and simple storage
COLOURS **MABS:** Brown and Turquoise
MABM: Black
MABL: Dark Red and Gold

3 SLEIGH BELLS

SIZES **SLB7:** 7 bells; **SLB12:** 12 bells; **SLB25:** 25 bells
MATERIALS Steel bells; Wooden handle
FEATURES Ergonomic grip; True sleigh bell sound

4 KOKIRIKO

MATERIAL Wood
FEATURES Ergonomically shaped handle; Durable cord
COLOUR **AM:** Amber

5 ORCHESTRA RATCHET

MATERIALS Chrome plated steel
 Hood Pine Tines
FEATURES Produce quick notes like a cabasa or long-sustaining rattle effects; Wooden internal paddles project clearly; Easy to grip metal hand crank; Mountable on a stand

6 WOODEN FROGS

SIZES **M:** Medium; **L:** Large
FEATURE Authentic "ribbit" sound

7 TRIANGLES

SIZES **TRI10B:** 4"
TRI15B: 6"
TRI20B: 8"
MATERIAL Solid brass
INCLUDES Wooden holder with braided nylon cord
 Metal beater

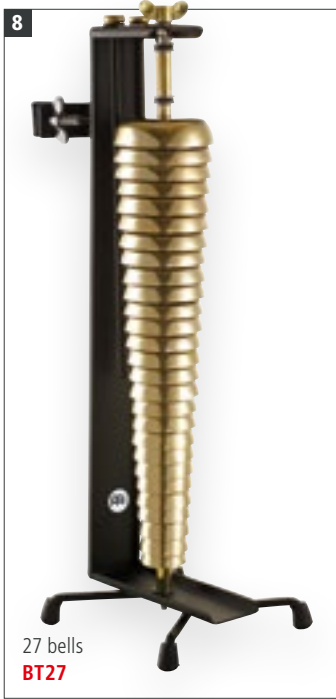

27 bells
BT27



14 bells
BT14



FICY-14

SPECIAL BRONZE ALLOY

SOUND EFFECTS



PFICY-2



FICY-2

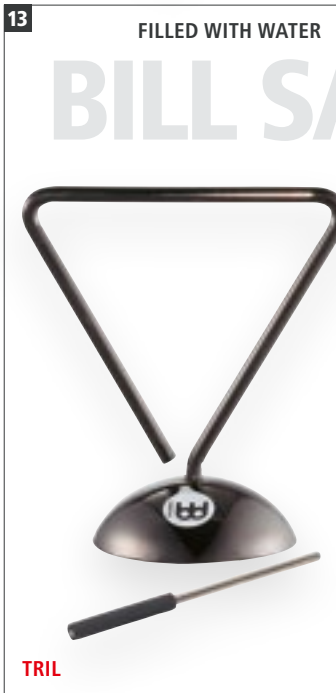

TRIL

FILLED WITH WATER

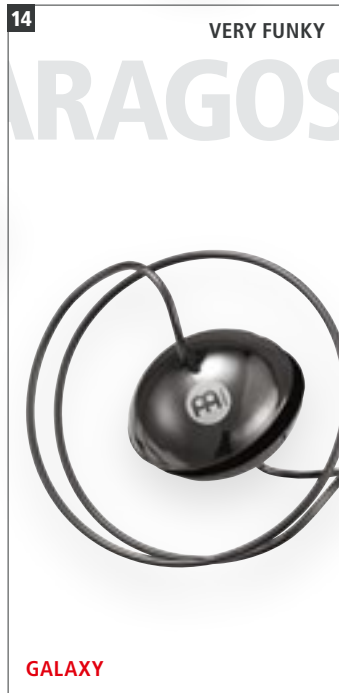

GALAXY

VERY FUNKY



BOWL

15



WW2BK



N11AM

17

8 STAND ALONE BELL TREE

MATERIAL Solid brass bells
FEATURE Adjustable metal stand
INCLUDES Striker

9 HAND HELD BELL TREE

MATERIAL Solid brass bells
INCLUDES Striker

10 HANGING FINGER CYMBALS

SIZES 2 3/8" diameter
MATERIAL Special bronze alloy
FEATURES Shimmering sound; Durable cord

11 PROFESSIONAL FINGER CYMBALS

SIZE 2 5/8" diameter
MATERIAL Special bronze alloy
FEATURES Identical, high pitched sound; Durable cord

12 ORIENTAL FINGER CYMBALS

SIZE 2 3/8" diameter
MATERIAL Special bronze alloy

BILL SARAGOSA LINE 13 14 15

MATERIAL Special steel alloy
FEATURE Wide sound spectrum
FINISH Black nickel

13 LIQUID TRIANGLE

FEATURES Special steel alloy, filled with water
INCLUDES Metal beater

14 GALAXY

FEATURES Two resonant liquid chambers are connected by a long steel spiral liquid; Inside the two chambers exerts variable dampening on the steel resonator plates
INCLUDES Metal beater

15 HELIX BOWL

FEATURES Wonderful instrument consisting of a steel helix welded to a resonating chamber; Deep resonating wah-wah effect
INCLUDES Metal beater

16 WAH-WAH TUBE

SIZE Large (low pitch)
MATERIAL Aluminum
INCLUDES Rubber mallet
COLOUR **BK:** Black

17 THE NIGHT

MATERIALS Solid steel balls and cylinder
Wooden body
COLOUR **AM:** Amber

CHIMES

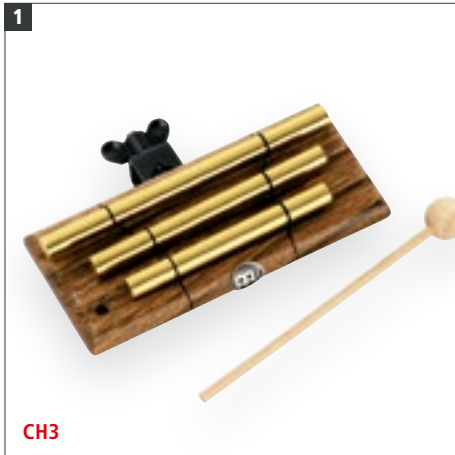

CH3



12 bars
CH-H12

18 bars
CH-H18

24 bars
CH-H24



12 pegs
CH-HPEG



27 bars, single row
HCH1R



33 bars, single row
HCH2BK



27 bars, single row
CH27VWB

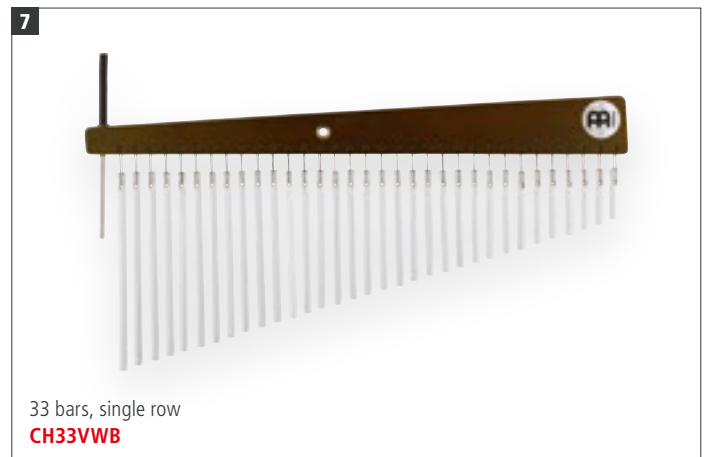

33 bars, single row
CH33VWB

1 TRI TONE CHIMES

MATERIAL Gold anodized aluminum alloy
FEATURES Three free-floating bars create a very long sustain
Tonally matched bars
Mountable on all common L-rods
INCLUDES Wooden beater and holder

2 HAND CHIMES

SIZES **CH-H12:** 12 bars
CH-H18: 18 bars
CH-H24: 24 bars
MATERIAL Gold anodized aluminum alloy
FEATURES Can easily be played by hand
Produce a full and rich sound

3 PEG CHIMES

SIZE 12 pegs
MATERIAL Gold plated steel
FEATURE Perfect for special accents

4 HEADLINER® SERIES CHIMES, 27 BARS

SIZE 27 bars, single row
MATERIAL Silver anodized aluminum alloy
FEATURES Great and affordable addition to any percussion set-up
Produce a full and warm chime sound
COLOUR **R:** Red

5 HEADLINER® SERIES CHIMES, 33 BARS

SIZE 33 bars, single row
MATERIAL Silver anodized aluminum alloy
FEATURE Generate a full sound spectrum
COLOUR **BK:** Black

6 VINTAGE CHIMES, 27 BARS

SIZE 27 bars, single row
MATERIAL Silver anodized aluminum alloy
FEATURE Excellent addition to any drum or percussion arrangement
COLOUR **VWB:** Vintage Wine Barrel

7 VINTAGE CHIMES, 33 BARS

SIZE 33 bars, single row
MATERIAL Silver anodized aluminum alloy
FEATURES Can be used in a wide range of musical styles
Producing a sweet sparkling sound
INCLUDES Holder; Striker
COLOUR **VWB:** Vintage Wine Barrel

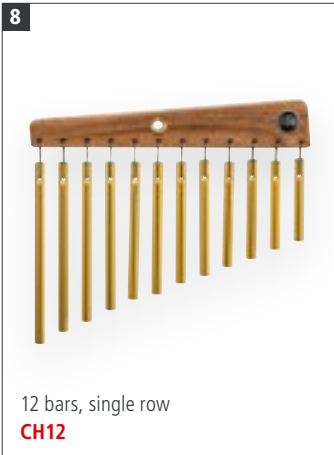

12 bars, single row
CH12



27 bars, single row
CH27ST



27 bars, single row
CH27

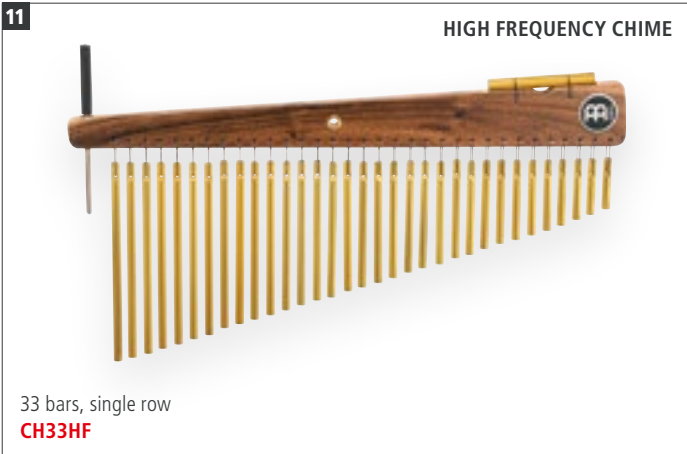

33 bars, single row
CH33HF



66 bars, double row
CH66HF

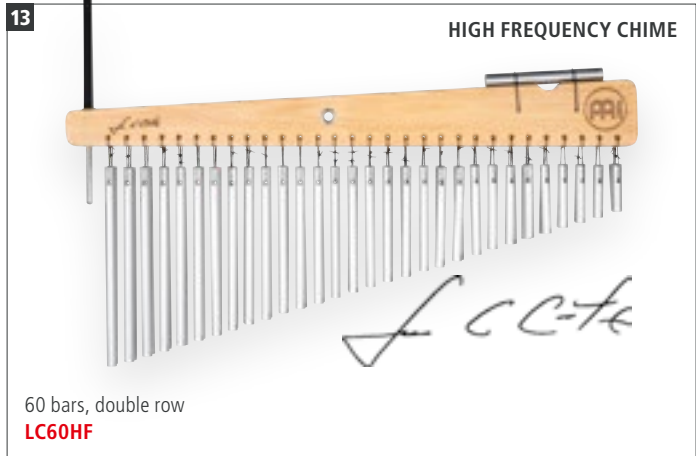

60 bars, double row
LC60HF



LUIS CONTE

8 CHIMES, 12 BARS
SIZE 12 bars, single row
MATERIAL Gold anodized aluminum alloy
FEATURES Produce a beautiful, high pitched sound
 Ideal for tasteful chime accents

9 STUDIO CHIMES, 27 BARS
SIZE 27 bars, single row
MATERIAL Gold anodized aluminum alloy
FEATURE Slightly thinner bars for a full, rich and delicate sound

10 CHIMES, 27 BARS
SIZE 27 bars, single row
MATERIAL Gold anodized aluminum alloy
FEATURES Produce a full sound with a wide tonal spectrum
 Ideal for smaller stages and club scenes

11 CHIMES, 33 BARS
SIZE 33 bars, single row
MATERIAL Gold anodized aluminum alloy
FEATURES Produce a very bright sound with a pronounced upper overtone spectrum
 Perfect for all live situations
INCLUDES Holder; Striker

12 CHIMES, 66 BARS
SIZE 66 bars, double row
MATERIAL Gold anodized aluminum alloy
FEATURES Produces a rich and full sound
 Cut through any band setting
INCLUDES Holder; Striker

13 ARTIST SERIES CHIMES LUIS CONTE
SIZE 60 bars, double row
MATERIAL Silver anodized aluminum alloy
FEATURES Produces a bright sound from the medium and low pitched bars
 Perfect for all studio situations
INCLUDES Holder; Striker

DIDGERIDOOS



1 WOOD DIDGERIDOOS

SIZE 47"
 MATERIAL Bamboo
 TUNING **DDG1-BK**: E
DDG1-BR: D#
DDG1-R: E
 COLOURS **BK**: Black
BR: Brown
R: Red

2 SYNTHETIC DIDGERIDOOS

SIZE 51"
 MATERIAL Lightweight synthetic
 TUNING **SDDG1-BK**: D
SDDG2-BK: C#
 FEATURES **SDDG2-BK**
 "S" shaped body for bigger sounds
 Distinctive, full drone and harmonic overtones
 COLOUR **BK**: Black

3 TROMBONE DIDGERIDOO

SIZE 36"-62"
 MATERIAL Premium fiberglass
 TUNING from: G#, G, F#, F, E, D#, D, C#, C
 FEATURE Two telescoping sections for variable pitch
 COLOUR **BK**: Black



SMALL IN SIZE BUT BIG IN SOUND

DIDGERIDOOS

4 SYNTHETIC SLIDE TRAVEL DIDGERIDOO

SIZE Portable: 24"; Playable: 60"
MATERIAL Lightweight synthetic
TUNING D
FEATURES Contractible body for easy travel
Distinctive, full drone and harmonic overtones
INCLUDES Bag
COLOUR **BK:** Black

5 PRO FIBERGLASS DIDGERIDOO

SIZE 57"
MATERIAL Premium fiberglass
TUNING D
COLOUR **BK:** Black

6 PRO SYNTHETIC DIDGERIDOO

SIZE 57"
MATERIAL Lightweight synthetic
TUNING D
COLOUR **BK:** Black

7 ARTIST SERIES DIDGERIDOO SIMON "SI" MULLUMBY

SIZE 61"
MATERIAL Premium fiberglass
TUNING F
COLOUR Grey

8 TRAVEL DIDGERIDOO (US PATENT)

SIZE 8 1/2" x 5"
MATERIAL Mahogany Wood (*Swietenia macrophylla*)
TUNING C
FEATURES Heat-branded logo
Compact size

9 DIDGERIDOO MOUTHPIECE

SIZE Inner diameter: 30 mm
Outer diameter: 60 mm
MATERIAL Antiseptic beeswax
FEATURES Easy mountable
100% pure beeswax
Fits perfect on our didgeridoos

RAINSTICKS & RAINMAKER

1

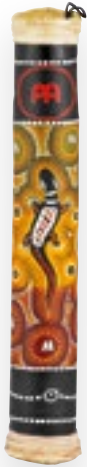

16"
RS1BK-S



24"
RS1R-M

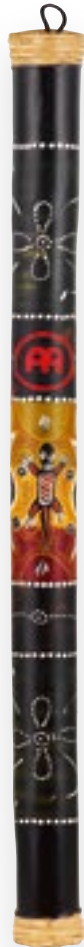

31 1/2"
RS1BK-M/L

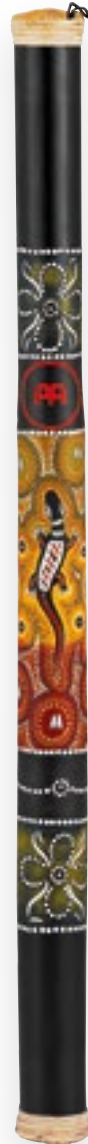

39"
RS1BK-L

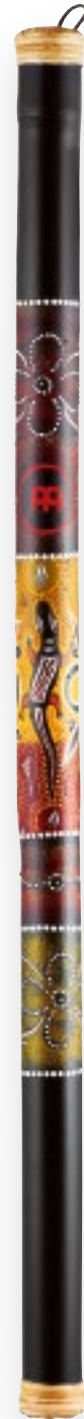

47"
RS1BK-XL



60"
RS1BK-XXL



1 WOOD RAINSTICKS

SIZES
S: 16"
M: 24"
M/L: 31 1/2"
L: 39"
XL: 47"
XXL: 60"
 MATERIAL Bamboo
 COLOURS **BK:** Black
R: Red

2 SYNTHETIC RAINSTICK

SIZE **L:** 39"
 MATERIAL Lightweight synthetic
 COLOUR **R:** Red

3 PRO RAINSTICK

SIZE **XL:** 47"
 MATERIAL Rattan wrapped Bamboo
 FEATURES Long susurration
 Authentic rain sounds

4 PRO RAINMAKER

SIZE 3 3/4" W x 25 1/4" H x 3 3/4" D
 MATERIAL Baltic Birch (*Betula pendula*)
 FEATURES Ultra long sustain
 Authentic rain sound
 Natural birch wood construction
 COLOUR **NT:** Natural



SAMBA

A close-up, artistic photograph of a brass instrument, likely a trombone, focusing on the slide and valves. The instrument is rendered in sharp detail against a dark background with soft, out-of-focus bokeh lights in warm tones, creating a dramatic and atmospheric effect.

Samba percussion instruments are the heartbeat of Brazil's vibrant Samba music, driving the lively rhythms that define this iconic genre. Instruments like the surdo, tamborim, and pandeiro create the powerful, syncopated beats that bring energy to Samba performances, from street parades to stage shows. Each instrument plays a unique role, blending deep, resonant bass with sharp, bright tones to form the intricate layers of Samba's rhythmic pulse. Whether you're playing in a Samba band or exploring its infectious rhythms on your own, these instruments offer an exciting, dynamic way to experience the spirit of Brazil.

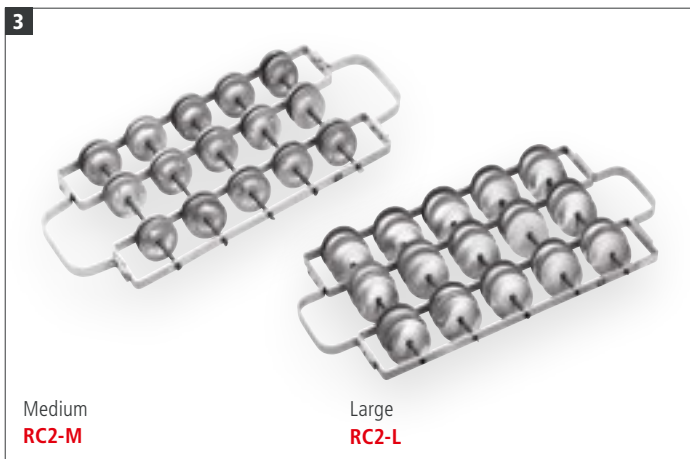
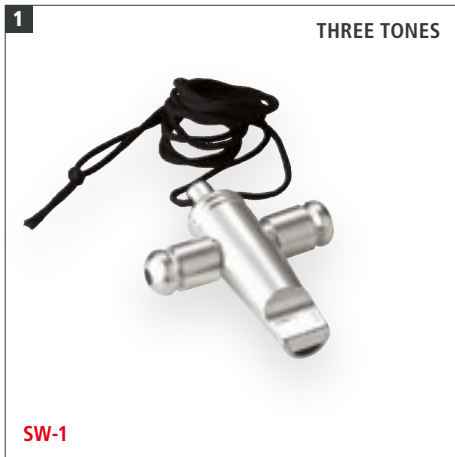

1 SAMBA WHISTLE

MATERIAL Aluminum
INCLUDES Neck lanyard

2 ALUMINUM SAMBA SHAKERS

SIZES **S**: Small; **M**: Medium; **L**: Large
MATERIAL Aluminum
FEATURE Produces warm and cutting shaker sound

3 ALUMINUM ROCARS

SIZES **RC2-M**: Medium; **RC2-L**: Large
MATERIAL Aluminum frame and jingles
FEATURES Light weight frame; Loud projection

4 MODERN STYLE A-GO-GO STEEL FINISH MODELS

SIZES **STBAG1, STBAG5**: Small
STBAG2: Large

MATERIAL Special steel alloy
FEATURE Tonally matched
FINISHES **STBAG1, STBAG2**: Hand brushed steel
STBAG5: Black powder coating

5 MODERN STYLE A-GO-GO CHROME FINISH MODELS

SIZES **STBAG4**: Small; **STBAG2**: Large
MATERIAL Special steel alloy
FEATURES Flexible connection; Bright sound
FINISH High polished chrome

6 TRADITIONAL STYLE A-GO-GO BELL

SIZE Medium
MATERIAL Special steel alloy
FEATURES Traditional shape; Flexible connection
FINISH High polished chrome

7 TRIPLE A-GO-GO BELL

SIZE Medium
MATERIAL Chrome plated steel
FEATURES Traditional Shape; Three tonally matched bells in equal intervals; Spring handle enables counterpoint rhythms

ALUMINUM SURDOS



1 CLASSIC SERIES SURDOS (PATENTED)

SIZES **SUC16:** 16" diameter, 20" tall
SUC18: 18" diameter, 22" tall
SUC20: 20" diameter, 24" tall

MATERIAL Aluminum

FEATURES Countersunk bolt heads
Traditional rim
Chrome plated hardware
Traditional plain shell
8 tuning lugs (16" & 18" models)
10 tuning lugs (20" model)
Logo applied from underneath the head
(CN, TH, US patent)

INCLUDES Tuning key

2 BAHIA ALUMINUM SURDOS (PATENTED)

SIZES **SUB18:** 18" diameter, 16" tall
SUB20: 20" diameter, 16" tall
SUB22: 22" diameter, 18" tall

MATERIAL Aluminum

FEATURES Countersunk bolt heads
Chrome plated hardware
Two head options
8 tuning lugs (18" model)
10 tuning lugs (20" & 22" models)
Logo applied from underneath the head
(CN, TH, US patent)

INCLUDES Tuning key

3 TRADITIONAL ALUMINUM SURDOS (PATENTED)

SIZES **SU16:** 16" diameter, 20" tall
SU18: 18" diameter, 22" tall
SU20: 20" diameter, 24" tall
SU22: 22" diameter, 24" tall

MATERIAL Aluminum

FEATURES Countersunk bolt heads
Chrome plated hardware
Two head options
8 tuning lugs (16" & 18" models)
10 tuning lugs (20" & 22" models)
Logo applied from underneath the head
(CN, TH, US patent)
SU22-L, SU20-L, SU18-L, SU16-L:
Height adjustable legs

INCLUDES Tuning key

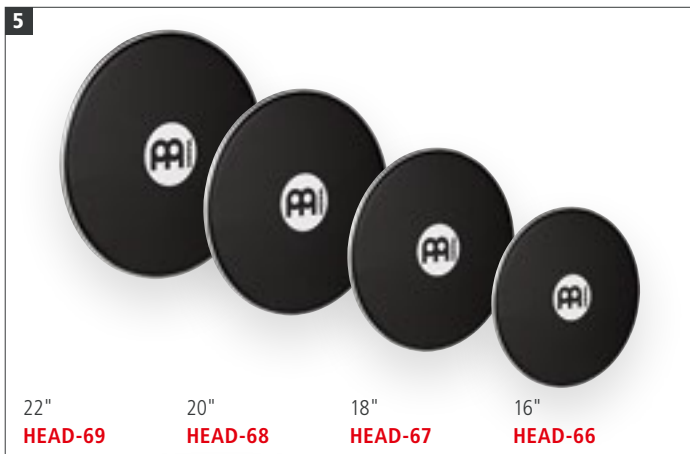

22" **HEAD-69** 20" **HEAD-68** 18" **HEAD-67** 16" **HEAD-66**



SHORTER SHELLS ENABLE TO WEAR IN MUCH LOWER POSITION

22" **SUB22AB-M** 20" **SUB20AB-M** 18" **SUB18AB-M**



22" **SU22AB-M** 20" **SU20AB-M** 18" **SU18AB-M** 16" **SU16AB-M**

SIX-PLY HARDWOOD SHELLS FOR A FULL AND WARM SOUND



22" **SU22-L-AB-M** 20" **SU20-L-AB-M** 18" **SU18-L-AB-M** 16" **SU16-L-AB-M**

HEIGHT ADJUSTABLE LEGS

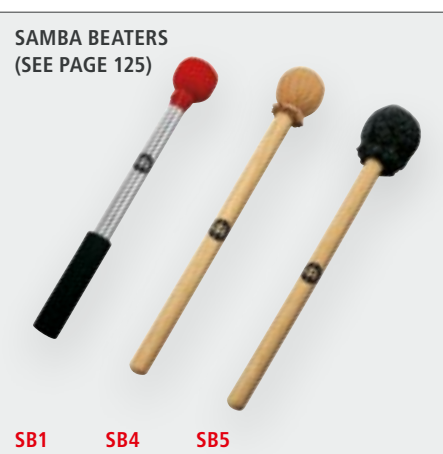

SAMBA BEATERS (SEE PAGE 125)

SB1 **SB4** **SB5**

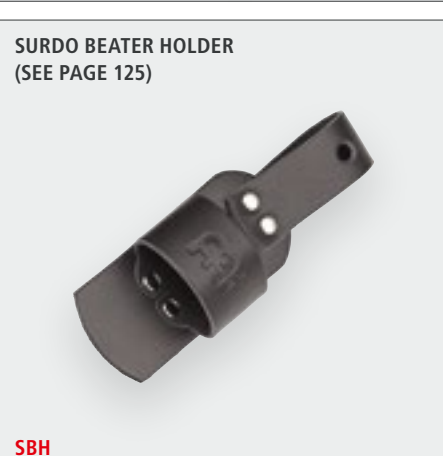

SURDO BEATER HOLDER (SEE PAGE 125)

SBH

4 SAMBA BELT

MATERIAL Cotton
FEATURES Length adjustable
 Adjustable shoulder padding
 Strong attachment hooks
COLOUR **R:** Red

5 SURDO NAPA HEADS

SIZES **HEAD-66:** 16"
HEAD-67: 18"
HEAD-68: 20"
HEAD-69: 22"
MATERIALS Nylon and leather cloth
FEATURE Bonded in a hoop
COLOUR Black

6 BAHIA WOOD SURDOS (PATENTED)

SIZES **SUB18:** 18" diameter, 16" tall
SUB20: 20" diameter, 16" tall
SUB22: 22" diameter, 18" tall
MATERIAL Six-ply hardwood shells
FEATURES Countersunk bolt heads
 Chrome plated hardware
 Two head options
 8 tuning lugs (18" model)
 10 tuning lugs (20" & 22" models)
 Logo applied from underneath the head (CN, TH, US patent)
INCLUDES Tuning key
COLOUR **AB:** Antique Brown
FINISH Matte

7 TRADITIONAL WOOD SURDOS (PATENTED)

SIZES **SU16:** 16" diameter, 20" tall
SU18: 18" diameter, 22" tall
SU20: 20" diameter, 24" tall
SU22: 22" diameter, 24" tall
MATERIAL Six-ply hardwood shells
FEATURES Countersunk bolt heads
 Chrome plated hardware
 Two head options
 8 tuning lugs (16" & 18" models)
 10 tuning lugs (20" & 22" models)
 Logo applied from underneath the head (CN, TH, US patent)
SU22-L, SU20-L, SU18-L, SU16-L: Height adjustable legs
INCLUDES Tuning key
COLOUR **AB:** Antique Brown
FINISH Matte

TIMBAS, TANTAM, REBOLO, REPINIQUES & CUICAS

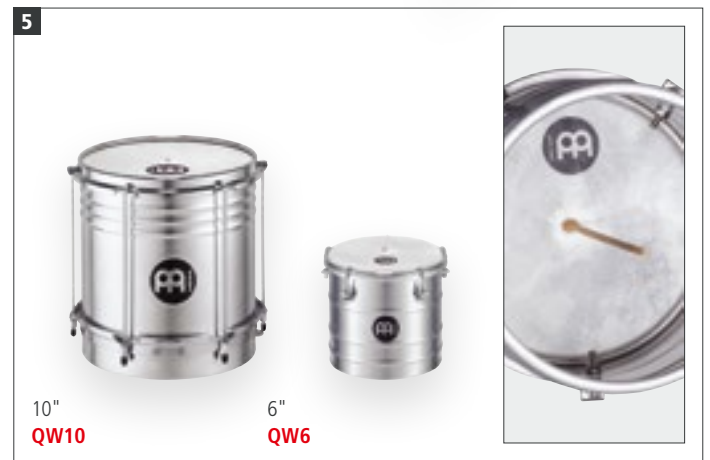
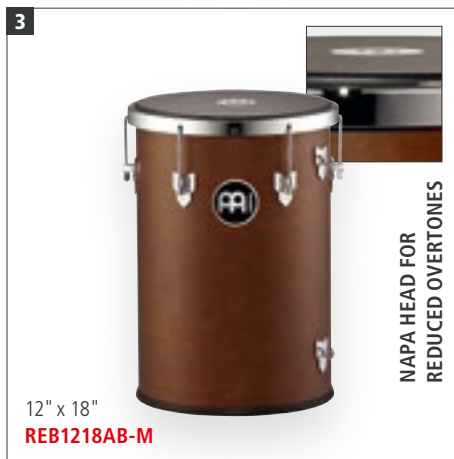

1 TIMBAS (PATENTED)

SIZES **TIM1428:** 14" diameter, 28" tall
TIM1435: 14" diameter, 35" tall

MATERIALS Poplar Wood (*Populus*)
Replaceable synthetic head

FEATURES Lightweight shell; Chrome plated hardware; Comfortable rounded rim; Strong hook to carry it on a belt; Logo applied from underneath the head (CN, TH, US patent)

INCLUDES Tuning key

COLOUR **AB-M:** Antique Brown, matte

2 TANTAM

SIZE 14" diameter, 28" tall

MATERIALS Poplar Wood (*Populus*)
Replaceable synthetic Napa head

FEATURES Lightweight shell; Chrome plated hardware; Strong hooks to carry it on a belt

INCLUDES Tuning key

COLOUR **AB-M:** Antique Brown, matte

3 REBOLO

SIZE 12" diameter, 18" tall

MATERIALS Poplar Wood (*Populus*)
Replaceable synthetic Napa head

FEATURES Lightweight shell; Chrome plated hardware; Mechanical lug tuning; Strong hooks to carry it on a belt

INCLUDES Tuning key

COLOUR **AB-M:** Antique Brown, matte

4 ALUMINUM REPINIQUES (PATENTED)

SIZES **RE10:** 10" diameter, 10" tall
RE12: 12" diameter, 12" tall

MATERIALS Aluminum
Replaceable synthetic heads

FEATURES Countersunk bolt heads; Chrome plated hardware; 6 tuning lugs (10" model); 8 tuning lugs (12" model); Logo applied from underneath the head (CN, TH, US patent)

INCLUDES Tuning key

5 ALUMINUM CUICAS

SIZES **QW6:** 6" diameter
QW10: 10" diameter

MATERIALS Aluminum
Hand selected goatskin heads

FEATURE **QW10:** Countersunk bolt heads

INCLUDES Tuning key

CAIXAS & TAMBORIMS



SAMBA

6



PROFESSIONAL SNARE THROW-OFF MECHANISM



14" x 4"
CA14

12" x 4 1/2"
CA12

7

TRADITIONAL STYLE WITH GUITAR STRINGS



12" x 6"
CA12T

IMPROVED

8

MESH HEAD FOR SUPER LOW VOLUME PRACTICE



ABS, Black
STBR06ABS-BK

9



ABS, Black
TBR06ABS-BK



ABS, Green
TBR06ABS-GR

TAMBORIM STICKS (SEE PAGE 124)



TBR5-BK **TBR5-R**



ABS, Red
TBR06ABS-R



ABS, Yellow
TBR06ABS-Y

PROFESSIONAL TAMBORIM BAG (SEE PAGE 129)



MTAB-06



Aluminum
TBR06ALU



6 ALUMINUM CAIXAS (PATENTED)

SIZES **CA12:** 12" diameter, 4 1/2" tall
CA14: 14" diameter, 4" tall

MATERIALS Aluminum; Replaceable synthetic heads

FEATURES Countersunk bolt heads; Steel snare wires; Professional snare throw-off mechanism; Logo applied from underneath the head (CN, TH, US patent)

INCLUDES Tuning key

7 TRADITIONAL ALUMINUM CAIXA (PATENTED)

SIZE 12" diameter, 6" tall

MATERIALS Aluminum; Replaceable synthetic heads

FEATURES Traditional style snares made from guitar strings; Extra deep body; Countersunk bolt heads; Logo applied from underneath the head (CN, TH, US patent)

INCLUDES Tuning key

8 SILENT TAMBORIM

SIZE 6" diameter

MATERIALS Molded ABS

Replaceable mesh head

FEATURE Floatune Tuning System; Countersunk bolt lugs; Mesh head for super low volume practice

INCLUDES Washer as tuning key

COLOUR **BK:** Black

9 FLOATUNE TAMBORIMS (PATENTED)

SIZE 6" diameter

MATERIALS Replaceable synthetic heads

ABS: ABS
ALU: Aluminum

FEATURES Floatune Tuning System; Countersunk bolt lugs; Logo applied from underneath the head (CN, TH, US patent)

INCLUDES Washer as tuning key

COLOURS **BK:** Black
GR: Green
R: Red
Y: Yellow

POP OFF CONGAS

1



11 1/2"
VR-POH115-SH

9 1/2"
VR-POH95-SH

8"
VR-POH8-SH



11 1/2"
VR-POH115-NH



9 1/2"
VR-POH95-NH

8"
VR-POH8-NH

MAY BE PLAYED BY THEMSELVES AS A SMALL HAND DRUM

2

CAN BE TAKEN OFF THE DRUM INSTANTLY WITHOUT ANY TUNING

BOOM SERIES



11 1/2" x 24 1/2"
VR-CPO115-SH

9 1/2" x 23"
VR-CPO95-SH

8" x 21"
VR-CPO8-SH

Set, 3 pcs.
VR-CPOSET-SH

STACKABLE FOR EASY STORAGE AND TRANSPORTATION

SOFT SOUND SERIES

11 1/2" x 24 1/2"
VR-CPO115-NH

9 1/2" x 23"
VR-CPO95-NH

8" x 21"
VR-CPO8-NH

Set, 3 pcs.
VR-CPOSET-NH

1 POP OFF HEADS

SIZES **VR-POH8:** 8" head diameter
VR-POH95: 9 1/2" head diameter
VR-POH115: 11 1/2" head diameter

MATERIALS **SH:** Synthetic head
NH: Napa head

FEATURES Available as Napa style (soft sound) or standard synthetic (sharp sounds)
Instantly take on or off your Meinl Pop Off Conga
May be played by themselves as a small hand drum
Nylon-loop for easy removal
Pre-tuned

2 POP OFF CONGAS

SIZES **VR-CPO8:** 8" head diameter, 21" height
VR-CPO95: 9 1/2" head diameter, 23" height
VR-CPO115: 11 1/2" head diameter, 24 1/2" height
VR-CPOSET: 8" x 21"; 9 1/2" x 23"; 11 1/2" x 24 1/2"

MATERIALS Synthetic shell
SH: Synthetic head
NH: Napa head

FEATURES Synthetic shell is perfect for outdoor playing
Non-slip rubber bottom
Great for any skill level or style
Stackable for easy storage and transportation
SH: Removable, pre-tuned synthetic head for cutting sounds with sharp attack
NH: Removable, pre-tuned Napa head creates softer, warmer sound

INCLUDES **VR-CPOSET:** Three wooden beaters

POP OFF BASS DRUMS



1

REVERSE-DOT FOR DEEPER SOUNDS

14" VR-POHBD14-SH

12" VR-POHBD12-SH

10" VR-POHBD10-SH

14" VR-POHBD14-NH

12" VR-POHBD12-NH

10" VR-POHBD10-NH

2

CAN BE TAKEN OFF THE DRUM INSTANTLY WITHOUT ANY TUNING

BOOM SERIES

14" x 23 1/2" VR-BDPO14-SH

12" x 19 1/2" VR-BDPO12-SH

10" x 18" VR-BDPO10-SH

Set, 3 pcs. VR-BDPOSET-SH

STACKABLE FOR EASY STORAGE AND TRANSPORTATION

SOFT SOUND SERIES

14" x 23 1/2" VR-BDPO14-NH

12" x 19 1/2" VR-BDPO12-NH

10" x 18" VR-BDPO10-NH

Set, 3 pcs. VR-BDPOSET-NH

POP OFF CONGAS & BASS DRUMS

1 POP OFF BASS DRUM HEADS

SIZES VR-POHBD10: 10" head diameter
VR-POHBD12: 12" head diameter
VR-POHBD14: 14" head diameter

MATERIALS SH: Synthetic head
NH: Napa head

FEATURES Available as Napa style (soft sound) or standard synthetic (sharp sounds)
Instantly take on or off your Meinl Pop Off Bass Drum
Reverse Dot below the head for deeper sounds
May be played by themselves as a small hand drum
Nylon-loop for easy removal
Pre-tuned

2 POP OFF BASS DRUMS

SIZES VR-BDPO10
10" head diameter, 18" height
VR-BDPO12
12" head diameter, 19 1/2" height
VR-BDPO14
14" head diameter, 23 1/2" height
VR-BDPOSET
10" x 18"; 12" x 19 1/2"; 14" x 23 1/2"

MATERIALS Synthetic shell
SH: Synthetic head
NH: Napa head

FEATURES Synthetic shell is perfect for outdoor playing
Non-slip rubber bottom
Great for any skill level or style
Lower tones with great resonance
Reverse Dot below the head for deeper sounds
Stackable for easy storage and transportation
SH: Removable, pre-tuned synthetic head for cutting sounds with sharp attack
NH: Removable, pre-tuned Napa head creates softer, warmer sound

INCLUDES VR-BDPOSET: Three wooden beaters

CULTURE INSTRUMENTS

A close-up photograph of a person's hand playing a Meinl drum. The drum's head is white with a black circular logo that reads 'MEINL' and a stylized 'M' symbol. The drum's body is decorated with intricate, hand-painted designs in green, brown, and gold, featuring floral and geometric patterns. The background is dark, making the drum and the hand stand out.

Cultural percussion instruments like doumbeks, darbukas, ibo drums, and talking drums carry rich musical traditions from around the globe. The doumbek and darbuka, with their roots in Middle Eastern music, offer sharp, staccato rhythms and deep, resonant tones, perfect for intricate hand drumming patterns. Ibo drums, often used in African and Latin music, bring a unique ceramic timbre, while talking drums, known for their pitch-changing capabilities, are an integral part of West African communication and storytelling traditions. These instruments not only offer diverse sounds but also connect musicians to deep cultural histories, making them a powerful addition to any percussive setup.



BE1R



8 1/2" Bayan & 5 1/2" Dayan
TABLA



9" Bayan & 5 1/2" Dayan
PRO-TABLA



6 3/4" & 12" Iya
BA3BK

5 3/4" & 8 3/4" Itotele
BA2BK

5 1/4" & 8" Okonkolo
BA1BK

TRADITIONAL
TTR-RIMS

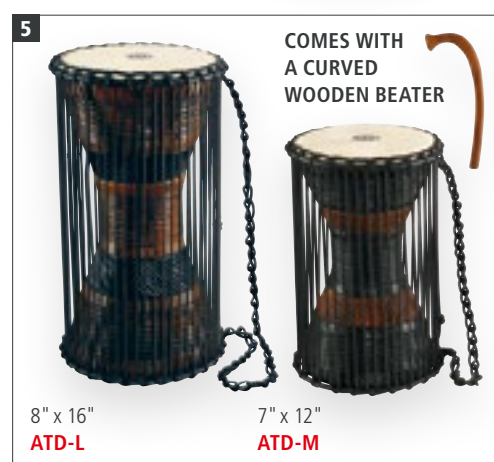

8" x 16"
ATD-L

7" x 12"
ATD-M

COMES WITH
A CURVED
WOODEN BEATER



White
ID10WH



ID3GO

ID4BKO

RAWHIDE PLAYING SURFACE

EXTRA FIBERGLASS PLAYING SURFACE



ID9BK/WH

THE FIBERGLASS LIQUID IBO
DRUM IS FILLED WITH WATER

1 BERIMBAU

MATERIAL Premium fiberglass
INCLUDES Small Caxixi; Metal plate; Wooden stick; Carrying bag
COLOUR **R:** Red

2 TABLA SET

SIZES 5 1/2" Dayan & 8 1/2" Bayan
MATERIALS Chrome plated copper with goatskin head
Mahogany with goatskin head
FEATURE Nylon straps for longer durability
INCLUDES Padded support rings; Tuning hammer

3 ARTISAN EDITION TABLA SET

SIZES 5 1/2" Dayan & 9" Bayan
MATERIALS Copper with goatskin head
Mahogany with goatskin head
FEATURES Traditional tuning system; Rawhide thongs
INCLUDES Tuning hammer and wooden tuning dowel; Ring pads; Protective head covers

4 BATAS

SIZES **BA1:** 5 1/4" & 8" Okonkolo
BA2: 5 3/4" & 8 3/4" Itotele
BA3: 6 3/4" & 12" Iya
MATERIALS Premium fiberglass
Hand selected buffalo heads
INCLUDES Nylon strap; Tuning key

5 AFRICAN WOOD TALKING DRUMS

SIZES **M:** 7" diameter, 12" tall
L: 8" diameter, 16" tall
PP ROPES **M:** 3 mm thickness, 23 runners
L: 3 mm thickness, 28 runners
MATERIALS Mahogany Wood (*Swietenia macrophylla*)
Hand selected goatskin heads
INCLUDES Curved wooden beater

6 QUINTO IBO DRUM

SIZE Small
MATERIAL Ceramic

FEATURE Built-in microphone hole
COLOUR **WH:** White

7 FIBERGLASS TRI SOUND IBO DRUMS

SIZE Large
MATERIAL Premium fiberglass
FEATURES Built-in microphone hole
ID3GO: Rawhide playing surface
ID4BKO: Extra fiberglass playing surface
INCLUDES Foam padded base
COLOUR **BKO:** Black Ornament
GO: Gold Ornament

8 FIBERGLASS LIQUID IBO DRUM

SIZE Large
MATERIAL Premium fiberglass
FEATURES Special bottom, filled with water;
Built-in microphone hole
INCLUDES Foam padded base
COLOUR **BK/WH:** Black/White

MINI & STANDARD DARBUKAS



1 MINI DARBUKAS

SIZE 4 1/4" diameter, 7 3/4" tall
MATERIALS Aluminum shell; All-weather synthetic head
FEATURES Fun to play and easy to carry; Great gift idea
HE-050: Plain shell
HE-051: Hand hammered shell
HE-052: Hand engraved shell
HE-053: Lacquered shell
INCLUDES Tuning key

2 COPPER DARBUKAS, HAND ENGRAVED

SIZES **HE-204:** 7 1/2" diameter, 14 3/4" tall
HE-205: 7 7/8" diameter, 15 1/2" tall
MATERIALS Copper shell; Natural rawhide
FEATURE Hand engraved shell
INCLUDES Tuning key

3 COPPER DARBUKAS, BRASS PLATED, HAND HAMMERED

SIZES **HE-214:** 7 1/2" diameter, 14 3/4" tall
HE-215: 7 7/8" diameter, 15 1/2" tall
MATERIALS Copper shell; Synthetic head
INCLUDES Tuning key

4 ALUMINUM DARBUKAS, HAND ENGRAVED

SIZES **HE-122:** 6 1/2" diameter, 12 3/4" tall
HE-124: 8" diameter, 14 1/2" tall
MATERIALS Aluminum shell; Synthetic head
INCLUDES Tuning key

5 ALUMINUM JINGLE DARBUKAS, HAND HAMMERED

SIZES **HE-314:** 8" diameter, 14 1/2" tall
HE-315: 8 1/4" diameter, 16" tall
MATERIALS Aluminum shell; Synthetic head
FEATURES Built-in jingles; Hand hammered shell
INCLUDES Tuning key

6 ALUMINUM DARBUKAS, HAND HAMMERED

SIZES **HE-110:** 5 1/3" diameter, 9 1/4" tall
HE-111: 5 7/8" diameter, 11" tall
HE-112: 6 1/2" diameter, 12 3/4" tall
HE-113: 7 1/4" diameter, 13 1/3" tall
HE-114: 8" diameter, 14 1/2" tall
MATERIALS Aluminum shell; Synthetic head
FEATURE Hand hammered shell
INCLUDES Tuning key

7 ALUMINUM DARBUKAS, PLAIN

SIZES **HE-100:** 5 1/3" diameter, 9 1/4" tall
HE-101: 5 7/8" diameter, 11" tall
HE-102: 6 1/2" diameter, 12 3/4" tall
HE-103: 7 1/4" diameter, 13 1/3" tall
HE-104: 8" diameter, 14 1/2" tall
MATERIALS Aluminum shell; Synthetic head
INCLUDES Tuning key

ARTISAN EDITION, MINI & STANDARD DOUMBEKS



1

8 3/4", White
HEAD-136

8 3/4", Black
HEAD-137

8 3/4", Clear
HEAD-138

NEW
9", Clear
HEAD-142

2

White Pearl, 8 3/4"
AEDD1

White Pearl, 8 3/4"
AEDD2

Blue Pearl, 8 3/4"
AEDD3

White Pearl, 9"
AEDD4

3

4"
HE-1030

4"
HE-1018

4

10"
HE-3218

8 1/2"
HE-3018

6"
HE-2018

HAND ENGRAVED SHELL

8 1/2"
HE-3039

PAINTED FLORAL DESIGN

5

8 1/2"
HE-3012

HAND ENGRAVED SHELL

6

8 1/2"
HE-3030

HAND HAMMERED SHELL

7

10"
HE-3200

8 1/2"
HE-3000

6"
HE-2000

LEATHERETTE COVERED SHELL

1 ARTISAN EDITION EGYPT DOUMBEK HEADS

SIZES **HEAD-136, HEAD-137, HEAD-138:** 8 3/4" diameter
HEAD-142: 9" diameter

MATERIAL Synthetic head

FEATURES Designed for the Meinl Artisan Edition Doumbeks

COLOURS **HEAD-136:** White; **HEAD-137:** Black; **HEAD-138, HEAD-142:** Clear

2 ARTISAN EDITION EGYPT DOUMBEKS

SIZES **AEDD1, AEDD2, AEDD3:** 8 3/4" diameter, 17" tall
AEDD4: 9" diameter, 18 3/4" tall

MATERIALS Aluminum shell; Synthetic head; Mother of pearl inlays

FEATURES Authentic Egyptian mosaic inlays; Produces outstanding dums and taks (teks)

INCLUDES Tuning key

DESIGNS **AEDD1:** Mosaic Royale; **AEDD2:** Mosaic

Imperial; **AEDD3:** Mosaic Palace; **AEDD4:** Mosaic Queen

3 MINI DOUMBEKS

SIZE 4" diameter, 7 1/2" tall

MATERIALS Aluminum shell; Synthetic head

FEATURES **HE-1018:** Hand engraved shell
HE-1030: Hand hammered shell

INCLUDES Tuning key

4 ALUMINUM DOUMBEKS, HAND ENGRAVED

SIZES **HE-2018:** 6" diameter, 12" tall (Soprano)
HE-3018, HE-3039: 8 1/2" diameter, 17 1/8" tall
HE-3218: 10" diameter, 18 1/4" tall (Bass)

MATERIALS Aluminum shell; Synthetic head

FEATURES **HE-2018:** High pitched articulate sounds
HE-3039: Painted floral design
HE-3218: Super deep tones

INCLUDES Tuning key

5 COPPER DOUMBEK, HAND ENGRAVED

SIZE 8 1/2" diameter, 17 1/8" tall

MATERIALS Copper shell; Synthetic head

INCLUDES Tuning key

6 ALUMINUM DOUMBEK, HAND HAMMERED

SIZE 8 1/2" diameter, 17 1/8" tall

MATERIALS Aluminum shell; Synthetic head

INCLUDES Tuning key

7 ALUMINUM DOUMBEKS

SIZES **HE-2000:** 6" diameter, 12" tall (Soprano)
HE-3000: 8 1/2" diameter, 17 1/8" tall
HE-3200: 10" diameter, 18 1/4" tall (Bass)

MATERIALS Aluminum shell (leatherette covered); Synthetic head

FEATURES **HE-2000:** High pitched articulate sounds
HE-3200: Super deep tones

INCLUDES Tuning key

COLOUR Black

HARDWARE



Our percussion hardware collection offers a wide range of sturdy stands, clamps, and accessories designed for durability and performance. Built to withstand the rigors of live shows and studio sessions, these pieces provide rock-solid support for your instruments, ensuring stability and precision. Whether you need adjustable conga stands, reliable clamps for your tambourines or shakers, or versatile mounts for your cymbals and drums, our hardware is crafted with high-quality materials to meet the demands of professional percussionists. Experience the confidence of using robust, well-engineered accessories that keep your setup secure and your focus on the music.



STANDS

1



Black powder coated

Chrome plated

Gold tone

Black powder coated

For Marathon® Classic Series
For Marathon® Designer Series
For Luis Conte Artist Series
ST-MCC11BK: 11"
ST-MCC1134BK: 11 3/4"
ST-MCC1212BK: 12 1/2"

Chrome plated

For Marathon® Exclusive Series
ST-MEC11CH: 11"
ST-MEC1134CH: 11 3/4"
ST-MEC1212CH: 12 1/2"
For Professional Series
For Fibercraft Series
ST-MP11CH: 11"
ST-MP1134CH: 11 3/4"
ST-MP1212CH: 12 1/2"
For Floatune Series
ST-FL10CH: 10"
ST-FL11CH: 11"
ST-FL12CH: 12"
ST-FL13CH: 13"
For Woodcraft Series
ST-WC11CH: 11"
ST-WC1134CH: 11 3/4"
ST-WC1212CH: 12 1/2"

Gold tone

For Marathon® Exclusive Series
ST-MEC11G: 11"
ST-MEC1134G: 11 3/4"
ST-MEC1212G: 12 1/2"
For Mongo Santamaria Artist Series
ST-MSA11G: 11"
ST-MSA1134G: 11 3/4"
ST-MSA1212G: 12 1/2"

QUICK AND EASY HEIGHT ADJUSTABILITY (DE PATENT)

2

EASY HEIGHT EXTENSION

Black powder coated
ST-HEBK

Chrome plated
ST-HECH

Gold tone
ST-HEG



3



MIN. 43"
MAX. 52 3/4"

For Headliner® congas
HDSTAND

For MCC congas
TMDS

4



For HDSTAND and TMDS
THBM

EASY MOUNTABLE

6



Chrome plated
MCH-CH

Gold tone
MCH-G

FOR ANY CONGA

5



Chrome plated
TMPDS

1 STEELY II CONGA STANDS (PATENTED)

MATERIAL Steel
FEATURES Metal spike attachment on each leg
L-shaped legs (DE, TH, US patent)
U-shaped notch for quick set up and breakdown (US patent)
Ergonomic arched rubber bracing for more stability (CN, DE, TH, US patent)
Notches for quick height adjustability (DE patent)
INCLUDES Hex key

2 STEELY II CONGA STAND HEIGHT EXPANDER SETS (DE PATENT)

MATERIAL Steel
FEATURE Easy and effective height extension
INCLUDES Mounting screws; Hex key
FINISHES **BK:** Black powder coated
CH: Chrome plated
G: Gold tone

3 CONGA DOUBLE STANDS

MATERIAL Steel
FEATURES Height adjustable
Double braced tripod legs
INCLUDES Hex key; Memory locks; Brackets; Set of screws, nuts, and washers; Mounting instructions

4 BONGO MOUNT

MATERIAL Chrome plated steel
FEATURES Easy mountable on our conga double stands HDSTAND and TMDS
Holds your bongo in place
Adjustable angle

5 PROFESSIONAL CONGA DOUBLE STAND WITH WHEELS

MATERIAL Chrome plated steel

FEATURES Height adjustable
Heavy construction
Double braced tripod legs
Lockable high-quality wheels
Padded separators for adjustable angle
Mounting instructions
INCLUDES Two mounting brackets

6 CONGA HANDLES

MATERIAL Steel
FEATURES Simple and safe add-on to help transport congas
Easily mountable with instructional guide
Fits any common conga
Leaves sound unaffected
INCLUDES Mounting screws and washers; Mounting instructions
FINISHES **CH:** Chrome plated
G: Gold tone

7 STURDY LOCKABLE WHEELS MAKE IT EASY TO MOVE THE STAND INTO POSITION

Chrome plated
TMPC

8 THE LIGHTWEIGHT STAND CAN BE FOLDED TO A COMPACT UNIT WHICH REQUIRES LITTLE SPACE

Chrome plated
TMC-CH

COMPATIBLE FOR ALL SIZES!

9

MIN. 34 1/2"
MAX. 50"

Black powder coated
THBS-BK

Chrome plated
THBS

AN INNOVATIVE BRACKET DESIGN ENABLES QUICK SET UP (PATENTED)

10 PADDED T-SHAPED TUBE FOR MORE STABILITY

MIN. 31 1/2"
MAX. 52 3/4"

Chrome plated
TMB

11 A STABLE METAL CLAMP HOLDS THE ENTIRE UNIT IN PLACE

MIN. 12 1/4"
MAX. 20"

Chrome plated
TMB-S

LOW HEIGHT FOR SEATED PLAYERS

12 PERFECT HEIGHT FOR CAJON PLAYERS

MIN. 22 3/4"
MAX. 29 1/2"

Black powder coated
THBS-S-BK

13 DIFFERENT RODS FOR ALL NEEDS

MIN. 31 1/2"
MAX. 52 1/2"

Chrome plated
TMPS

7 PROFESSIONAL CONGA STAND WITH WHEELS

- MATERIAL** Chrome plated steel
- FEATURES** Adjustable padded stops fit any conga size
Height adjustable legs
Lockable wheels

- FEATURES** Quick set up
Easy handling
Reliable placement
Double braced tripod stand
Fits all common bongos
- INCLUDES** Wrench
- FINISHES** **THBS:** Chrome plated
THBS-BK: Black powder coated

- FEATURES** Seated playing position possible
Padded T-shaped tube
Fully height and angle adjustable
Double braced tripod legs
Fits all common bongos
- INCLUDES** Hex key; Memory lock

8 PROFESSIONAL CONGA STAND

- MATERIAL** Chrome plated steel
- FEATURES** Unique design (DE patent)
Rubber padded crossbeams
Fully height adjustable
Folds up to a compact unit
- INCLUDES** Hex key; Memory locks

10 PROFESSIONAL BONGO STAND

- MATERIAL** Chrome plated steel
- FEATURES** Padded T-shaped tube
Fully height and angle adjustable
Double braced tripod legs
Fits all common bongos
- INCLUDES** Hex key; Memory locks

12 CAJON HEIGHT BONGO STAND

- MATERIAL** Black powder coated steel
- FEATURES** Quick set up
Easy handling
Perfect height for cajon players
Fits all common bongos

9 HEADLINER® SERIES BONGO STANDS (CN, DE, US PATENT)

- MATERIAL** Steel

11 PROFESSIONAL BONGO STAND FOR SEATED PLAYERS

- MATERIAL** Chrome plated steel

13 PERCUSSION STAND

- MATERIAL** Chrome plated steel
- FEATURES** Height adjustable
Double braced tripod legs
- INCLUDES** Hex key; Memory locks; 2 straight rods; 2 angled rods; 2 Z-shaped rods

STANDS

1 COLLAPSIBLE DESIGN



Black powder coated
STDJST-BK

2



QUICK AND EASY HEIGHT ADJUSTABILITY (DE PATENT)



Chrome plated
ST-DJEMBE

3 LENGTH ADJUSTABLE FOR VARIOUS DJEMBE SIZES



MIN. 23 1/2"
MAX. 37 3/4"



Chrome plated
TMD

4 FITS ALL CAJON SIZES



MIN. 26"
MAX. 40 1/2"

Black powder coated
TMCAJ

5



CMS

CAJON DRUM SET STANDS
(SEE PAGE 53)



CHS CCS CAS

6



MIN. 22"
MAX. 37"

Black powder coated
CPTS

7 SPECIAL LOW HEIGHT



MIN. 29 1/2"
MAX. 38"

Chrome plated
MLH

1 TRAVEL DJEMBE STAND

MATERIAL Black powder coated steel
FEATURES Collapsible design
Lightweight construction

2 STEELY II DJEMBE STAND (PATENTED)

MATERIAL Chrome plated steel
FEATURES Metal spike attached to each leg
L-shaped legs (DE, TH, US patent)
U-shaped notch for quick set up and breakdown (US patent)
Ergonomic arched rubber bracing for more stability (CN, DE, US patent)
Notches for quick height adjustability (DE patent)
Adapts to different djembe sizes
INCLUDES Hex key, 3 spacers

3 PROFESSIONAL DJEMBE STAND

MATERIAL Chrome plated steel
FEATURES Rubber padded hooks
Fully height and angle adjustable
Double braced tripod legs
INCLUDES Hex key; Memory lock

4 PROFESSIONAL CAJON STAND

MATERIAL Steel
FEATURES Quick set up
Fully height and angle adjustable
Double braced tripod stand
Fits all cajon sizes

5 CAJON MICROPHONE STAND

MATERIAL Black powder coated aluminum
FEATURES Round base for compact setup
Solid construction
Height adjustable

6 CAJON PICKUP TAPS STAND

MATERIAL Black powder coated aluminum
FEATURES Designed to mount the Meinl Cajon Pickup Tom and Snare Taps
Low-key stage footprint
L-Shaped 3/8" rod
Foldable legs, height adjustable

7 LOW HAT

MATERIAL Chrome plated steel
FEATURES Special low height
Made just for cajon players

8 TIMBALE STAND

MATERIAL Chrome plated steel
FEATURES Double braced tripod base
Height and angle adjustable
Standard mounting rod for auxiliary percussion



INCLUDES Accessory pouch; L-shaped tuning key; Tune Up Oil

9 PROFESSIONAL TIMBALE STAND

MATERIAL Chrome plated steel

FEATURES Heavy-duty double braced tripod base
Height and angle adjustable
Standard mounting rod for auxiliary percussion

INCLUDES Accessory pouch; Tuning key; Tune Up Oil

10 HAND-BALE STAND

MATERIAL Chrome plated steel

FEATURES Quick set up
Rubber-tipped three arm basket
Easy handling
Double braced tripod stand

11 PROFESSIONAL DOUMBЕК/IBO STAND

MATERIAL Chrome plated steel

FEATURES Foam padded ring
Fully height and angle adjustable
Double braced tripod legs

INCLUDES Hex key; Memory lock

12 DIDGERIDOO STAND

MATERIAL Black powder coated aluminum

FEATURES Steady support for your didgeridoo
Stable tripod base
Soft padding
Rubber yoke for added protection

FINISH Black

13 PROFESSIONAL DIDGERIDOO STAND

MATERIAL Black powder coated aluminum

FEATURES Dual leg base and strong aluminum construction
Protective rubber yoke and soft padding
Height and angle adjustable

FINISH Black

14 PRO DIDGERIDOO STAND

MATERIAL Chrome plated steel

FEATURES Play your didgeridoo in a seated or standing position
Accommodates most didgeridoo sizes and shapes
Padded rest with adjustable strap

15 CHIMES STAND

MATERIAL Chrome plated steel

FEATURES Full angle and height adjustability
Secure angle clamps
Telescoping stem

TABLES

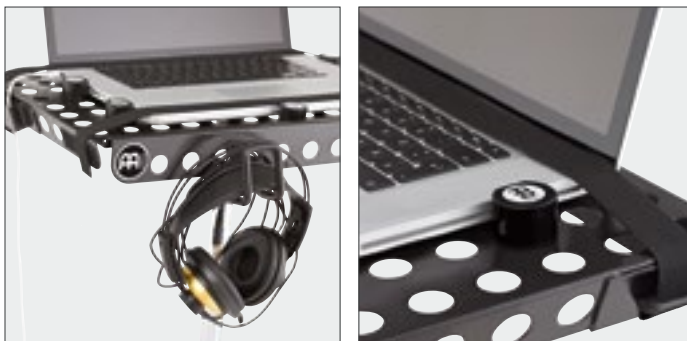

1 LAPTOP TABLE STAND

- SIZE** 20" x 12 1/2"
- MATERIAL** Perforated metal plate
- FEATURES** Holds laptops up to 17"
Stoppers, hook and loop fastener to secure the laptop
Holder for headphones
Cord strain relief

2 LIGHT LAPTOP TABLE STAND

- SIZE** 14 1/2" x 10 3/4"
- MATERIAL** Aluminum
- FEATURES** Holds laptops up to 16"
Fabric anti-slip surface
Height adjustable
Foldable legs

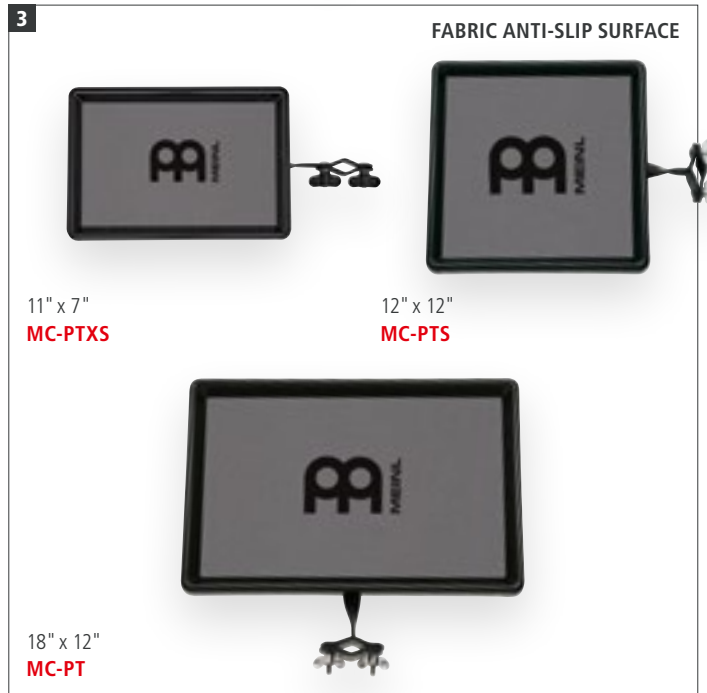

3 PERCUSSION TABLES

- SIZES** **MC-PT:** 18" x 12"
MC-PTS: 12" x 12"
MC-PTXS: 11" x 7"
- MATERIALS** **MC-PT, MC-PTS:** Premium fiberglass
MC-PTXS: Synthetic
- FEATURES** Fabric anti-slip surface
Adjustable angle
Strong mounting clamp

4

HEIGHT ADJUSTABILITY AT ALL POINTS

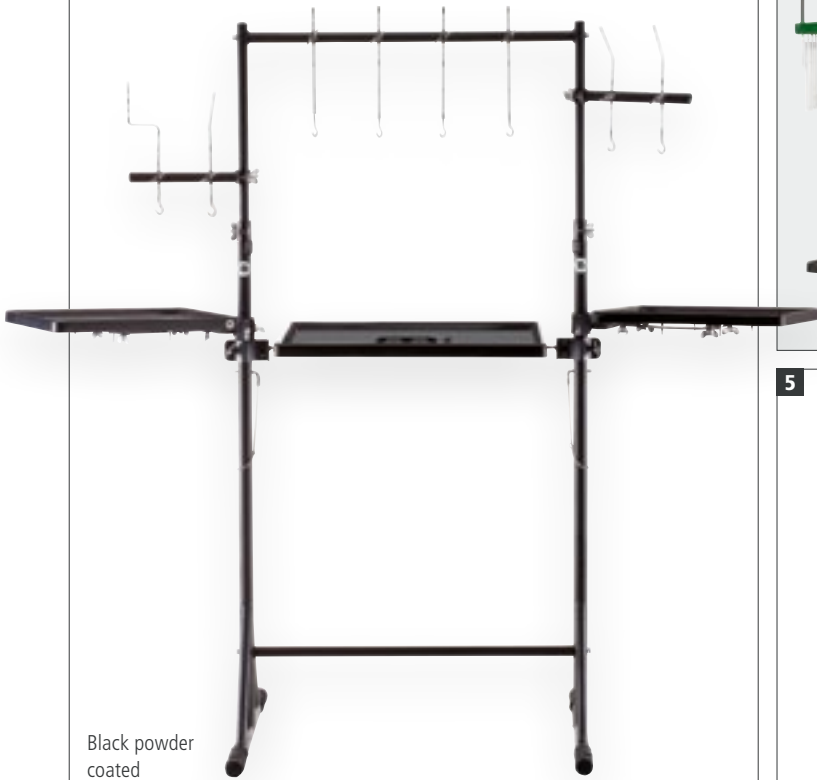

Black powder coated
TMPWS



5

ALL MEINL TRIPOD STANDS ARE EQUIPPED WITH MEMORY AND QUICK LOCKS



MIN. 30"
MAX. 46 3/4"

16" x 22"
TMPTS





4 PERCUSSION WORKSTATION

- MATERIAL** Black powder coated steel
- FEATURES** Fully height adjustable
Angle adjustable top bar
Heavy-duty construction
Infinitely expandable
Fabric anti-slip surfaces
Colour doesn't interfere with stage lighting
- INCLUDES** 1 x Padded fiberglass percussion table, 22" x 24"
2 x Padded fiberglass percussion tables, 18" x 12" (attachable)
1 x Vertical bar, 30"
2 x Vertical bars, 15" (attachable)
4 x Straight rods with hook
3 x Angled rods with hook
1 x Z-shaped rod with hook

5 PERCUSSION TABLE STAND

- SIZE** 16" x 22"
- MATERIALS** Table: Premium fiberglass
Stand: Chrome plated steel
- FEATURES** Fabric anti-slip surface
Fully height adjustable
Double braced tripod legs
- INCLUDES** Hex key
Memory lock

HARDWARE

<p>1 HOLDS TAMBOURINES AND SHAKERS</p>  <p>Mini Percussion Rack MC-SHTA</p>	<p>2 PADDLED SURFACE</p>  <p>Tambourine Holder MC-TH</p>	<p>3</p> <p>MIN. 1" MAX. 6"</p>  <p>Shaker Holder MC-SH</p>	
<p>4</p> <p>MIN. 2 1/2" MAX. 3 3/4"</p>  <p>Güiro Holder MC-GU</p>	<p>5</p>  <p>Wood Block Holder MWBH1</p>	<p>6</p>  <p>Standard Frame Drum Holder MC-STFDH</p>	<p>7</p>  <p>Triangle Holder MC-TRI</p>
<p>8</p>  <p>Triangle Clamp CLAMP-TRI</p>	<p>9 FOR TURBO CABASA, MEDIUM</p>  <p>Cabasa Holder MC-CA</p>	<p>10</p>  <p>Frame Drum Holder MC-FDH</p>	
<p>11</p>  <p>Chimes Holders MC-CH MC-CHL</p>	<p>12</p>  <p>Drumstick Holders MC-DSH MC-DSH-JB</p>	<p>13</p>  <p>Bass Drum Cowbell Holders MC-STBD MC-BD</p>	

1 MINI PERCUSSION RACK

MATERIALS Black powder coated steel; Foam rubber
FEATURE Holds tambourines and shakers
COLOUR Black

2 TAMBOURINE HOLDER

MATERIAL Chrome plated steel
FEATURES Rubber pads; Padded surface

3 SHAKER HOLDER

MATERIAL Chrome plated steel
FEATURES Rubber pads; Length adjustable

4 GÜIRO HOLDER

MATERIAL Chrome plated steel
FEATURE Rubber pads

5 WOOD BLOCK HOLDER

MATERIAL Chrome plated steel

6 STANDARD FRAME DRUM HOLDER

MATERIAL Chrome plated steel
FEATURE Perfect for frame drums or traditional wood tambourines

7 TRIANGLE HOLDER

MATERIAL Chrome plated steel
FEATURES Knurled surface; Nylon cord

8 TRIANGLE CLAMP

MATERIAL Chrome plated steel
FEATURES Holds any triangle in place; Easy mountable

9 CABASA HOLDER

MATERIAL Chrome plated steel
FEATURES Strong mounting clamp; Padded surface

10 FRAME DRUM HOLDER

MATERIALS Chrome plated steel; Anodized aluminum
FEATURE Fully adjustable for any frame drum size

11 CHIMES HOLDERS

SIZES **MC-CH**: Regular
MC-CHL: Large
MATERIAL Chrome plated steel
FEATURES Knurled surface; Foam washer

12 DRUMSTICK HOLDERS

MATERIALS Chrome plated steel; Black textile pouch
FEATURE Strong mounting clamp
FINISHES **MC-DSH**: Meinl
MC-DSH-JB: Jawbreaker motif

13 BASS DRUM COWBELL HOLDERS

MATERIALS **MC-BD**: Chrome plated steel
MC-STBD: Black powder coated steel
FEATURES Rubber pads
MC-BD: Fully adjustable
INCLUDES **MC-BD**: L-shaped rod

14

Multi Clamp for Cymbal Stands
PMC-1

15

Pedal Mount
PM-1

16

Pedal Mount for Cymbals
PM-2

17

Cymbal Stackers
MC-CYS **MC-CYS8** **MC-CYS8-S**

18

MC-CY1
MC-CY2
MC-CY

Cymbal Holder Attachments

20

Cymbal Attachment
MCA

19

X-Hat Cymbal Stand Adapter
MXHA

22

X-Hat Auxiliary Hihat Arm
MXH

21

Double Extension Arm
MDEA

14 MULTI CLAMP FOR CYMBAL STANDS
MATERIAL Chrome plated steel
FEATURES Double-sided clamp; Attach a cymbal or tom arm to any stand; Universal for all standard drum hardware; Metal body with durable synthetic thumb screws

15 PEDAL MOUNT
MATERIAL Black powder coated steel
FEATURES Height adjustable legs; Metal spikes; Fits on all common bass drum pedals and firmly holds cowbells, blocks, or tambourines
INCLUDES 2 differently sized L-rods

16 PEDAL MOUNT FOR CYMBALS
MATERIAL Black powder coated steel
FEATURES For foot activated cymbal crashes; Holds cymbals ranging from 16" to 22"
INCLUDES Cymbal arm

17 CYMBAL STACKERS
SIZES **MC-CYS:** Ø 6 mm, long
MC-CYS8: Ø 8 mm, long
MC-CYS8-S: Ø 8 mm, short
MATERIAL Chrome plated steel
FEATURE Felt washers

18 CYMBAL HOLDER ATTACHMENTS
MATERIAL Chrome plated steel
FEATURES Knurled surface; Felt washers; For splashes or small crashes; Easy placement on a drumkit, cajon set or percussion rig
MC-CY: Z-shaped 3/8" rod
MC-CY1: S-shaped 3/8" rod
MC-CY2: Z-shaped 3/8" rod with extra-long knurled end

19 X-HAT CYMBAL STAND ADAPTER
MATERIAL Chrome plated steel
FEATURES Turn any cymbal stand into an X-Hat stand; Fits 8 mm threaded cymbal stand posts; Use with any size hihat or stack

20 CYMBAL ATTACHMENT
MATERIAL Chrome plated steel
FEATURES Multi-clamp; Cymbal boom arm

21 DOUBLE EXTENSION ARM
MATERIAL Chrome plated steel
FEATURES Two points of 360-degree adjustability; Heavy-duty chrome plated steel; Length adjustable

22 X-HAT AUXILIARY HIHAT ARM
MATERIAL Chrome plated steel
FEATURE Easy to attach and position at any height or angle

HARDWARE



Mic. Cymbal Clamp Set
MPMCS

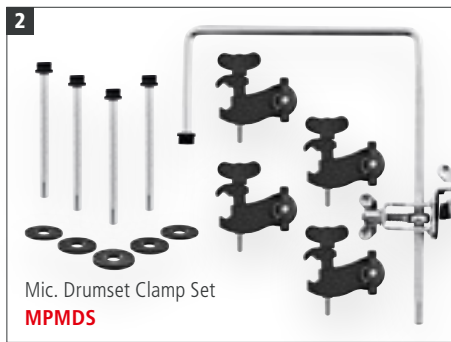

Mic. Drumset Clamp Set
MPMDS

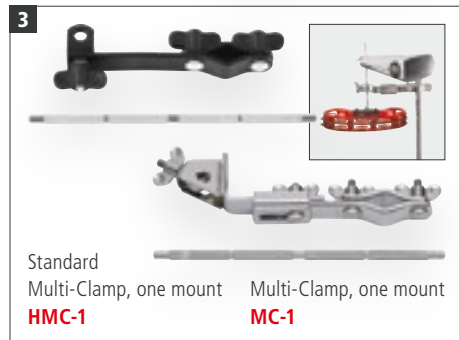

Standard Multi-Clamp, one mount
HMC-1 Multi-Clamp, one mount
MC-1

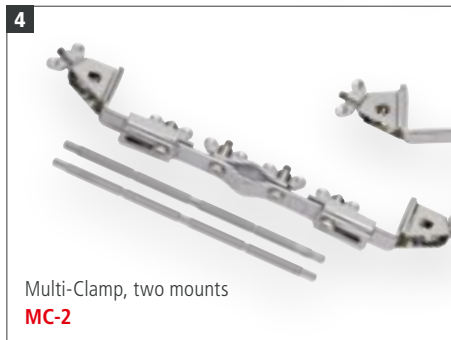

Multi-Clamp, two mounts
MC-2

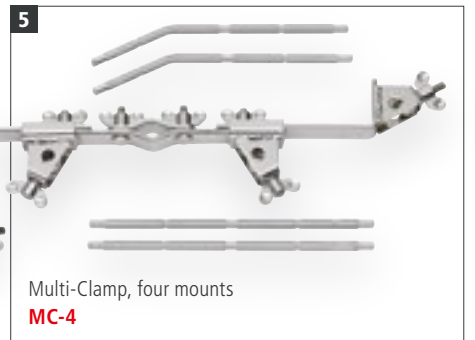

Multi-Clamp, four mounts
MC-4

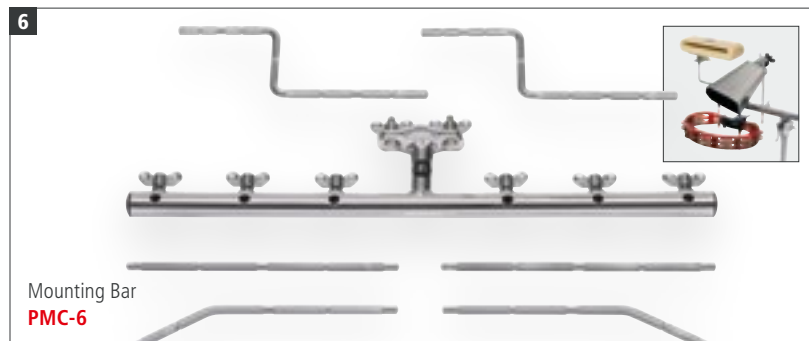

Mounting Bar
PMC-6

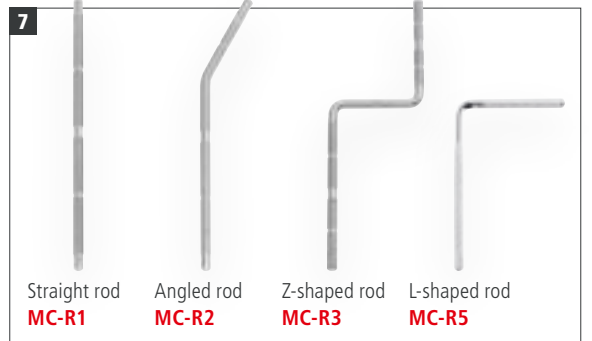

Straight rod
MC-R1 Angled rod
MC-R2 Z-shaped rod
MC-R3 L-shaped rod
MC-R5

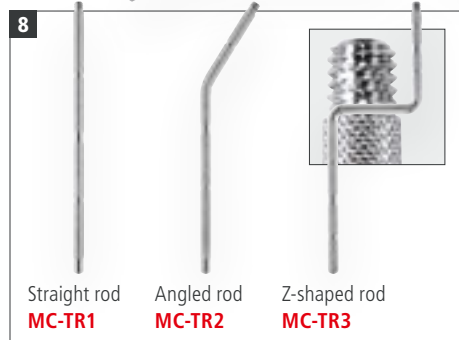

Straight rod
MC-TR1 Angled rod
MC-TR2 Z-shaped rod
MC-TR3

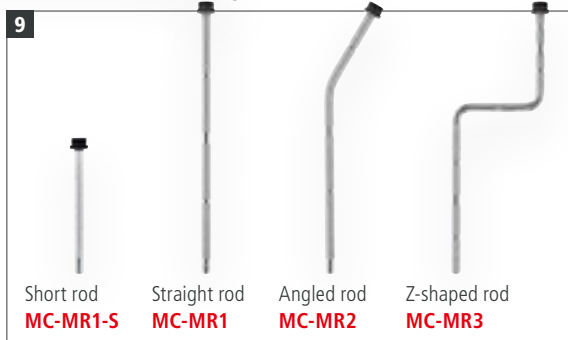

Short rod
MC-MR1-S Straight rod
MC-MR1 Angled rod
MC-MR2 Z-shaped rod
MC-MR3

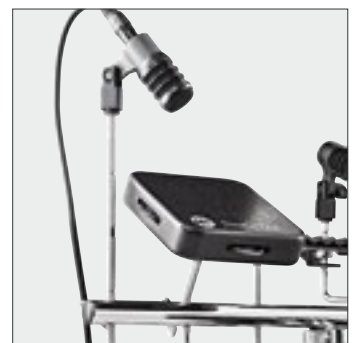

1 MICROPHONE CYMBAL CLAMP SET

CONTAINS 3 x Standard Multi-Clamp (HMC-1); 3 x Short Rod With Threaded Microphone Connector (MC-MR1-S); 1 x Microphone Rod Counter Nuts (MRCN5)

2 MICROPHONE DRUMSET CLAMP SET

CONTAINS 1 x Bass Drum Microphone Clamp (MC-MRBD); 4 x Rimclamp (RIMCLAMP-2); 4 x Short Rod With Threaded Microphone Connector (MC-MR1-S); 1 x Microphone Rod Counter Nuts (MRCN5)

3 MULTI-CLAMPS, ONE MOUNT

MATERIALS **HMC-1:** Black powder coated steel
MC-1: Chrome plated steel
FEATURES Strong mounting clamp
MC-1: Length adjustable
INCLUDES Straight rod

4 MULTI-CLAMP, TWO MOUNTS

MATERIAL Chrome plated steel
FEATURES Length adjustable; Strong mounting clamp
INCLUDES 2 straight rods

5 MULTI-CLAMP, FOUR MOUNTS

MATERIAL Chrome plated steel
FEATURES Length adjustable; Strong mounting clamp
INCLUDES 2 straight and 2 angled rods

6 MOUNTING BAR

MATERIAL Chrome plated steel
INCLUDES 2 straight, 2 angled and 2 z-shaped rods

7 RODS

MATERIAL Chrome plated steel
FEATURES Knurled surface; Available as a straight, angled, z-shaped, or l-shaped rod

8 THREADED PERCUSSION RODS

MATERIAL Chrome plated steel
FEATURE Threaded tip to mount any standard 3/8" threaded percussion instrument

9 RODS WITH THREADED MICROPHONE CONNECTOR

MATERIAL Chrome plated steel
FEATURES 3/8" diameter rod with threaded end; Designed to attach microphones; Use with the Meinl Rim Clamp; Available as a short, straight, angled, or z-shaped rod
INCLUDES Microphone screw adapter

10 BASS DRUM MICROPHONE CLAMP

MATERIAL Chrome plated steel
FEATURE U-shape 3/8" diameter rod with threaded end to attach a microphone



10
Bass Drum
Microphone Clamp
MC-MRBD

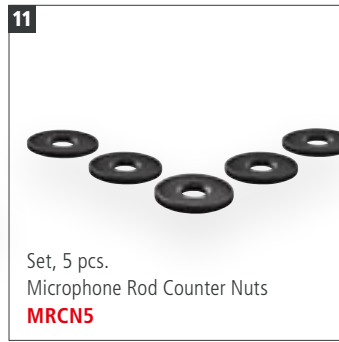

11
Set, 5 pcs.
Microphone Rod Counter Nuts
MRCN5

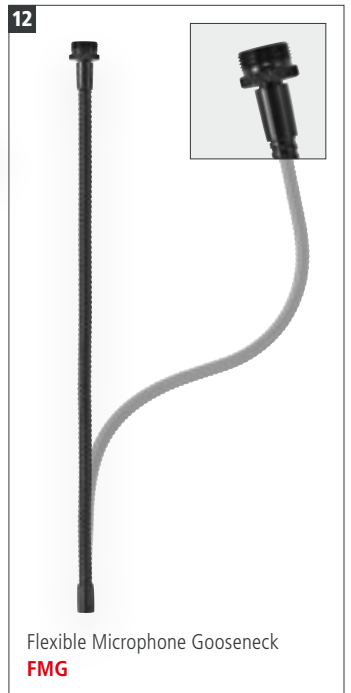

12
Flexible Microphone Gooseneck
FMG



13
Microphone
Cajon Clamp
MPMCC



14
Microphone
Adapter
TMMA



15
Clamp
CLAMP

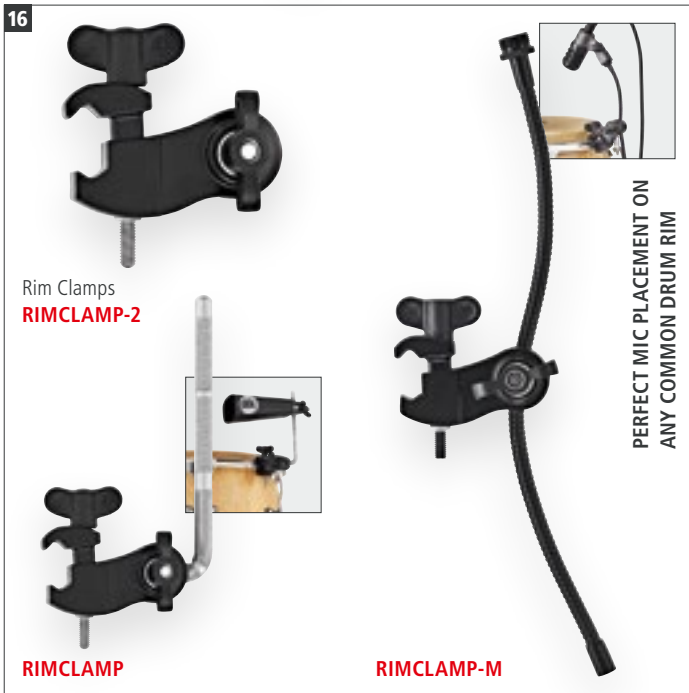

16
Rim Clamps
RIMCLAMP-2

RIMCLAMP

RIMCLAMP-M

PERFECT MIC PLACEMENT ON ANY COMMON DRUM RIM

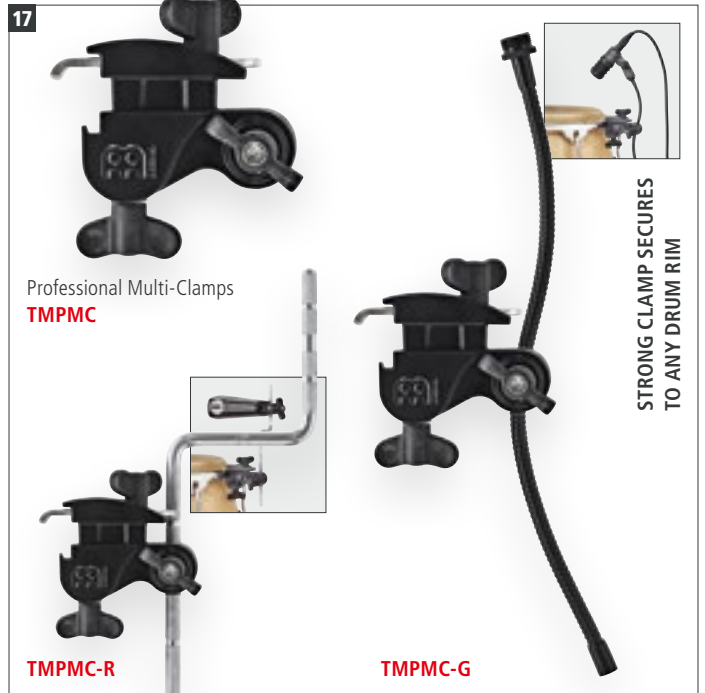

17
Professional Multi-Clamps
TMPMC

TMPMC-R

TMPMC-G

STRONG CLAMP SECURES TO ANY DRUM RIM

11 MICROPHONE ROD COUNTER NUTS

MATERIAL Black powder coated steel
FEATURES Set of 5 counter nuts; Securely lock your microphone attachments

12 FLEXIBLE MICROPHONE GOOSENECK

SIZE 12.8" (32.5 cm)
MATERIAL Metal
FEATURES Optimal microphone placement; No additional stand required; Fits in the Meinl Rim Clamp; 3/8" and 5/8" threads

13 MICROPHONE CAJON CLAMP

MATERIAL Steel
FEATURE Foam padding ensures quiet recording

14 MICROPHONE ADAPTER

MATERIAL Chrome plated steel
FEATURES Turns your cymbal stand into a microphone stand; 8 mm threaded attachment

INCLUDES 5/8" male to 3/8" mic screw adapter

15 CLAMP

MATERIAL Chrome plated steel
FEATURE Compact and solid design

16 RIM CLAMPS

MATERIALS Black powder coated steel
RIMCLAMP: Chrome plated steel (L-shaped rod)
RIMCLAMP-M: Metal (Gooseneck)
FEATURES Fully height and angle adjustable; Fits to any common drum rim
RIMCLAMP, RIMCLAMP-2: Holds percussion accessories right where you need them
RIMCLAMP-M: Works with all 3/8" or 5/8" mic clips (Mic clip not included)

INCLUDES **RIMCLAMP:** L-shaped rod
RIMCLAMP-M: Flexible Microphone Gooseneck

17 PROFESSIONAL MULTI-CLAMPS

MATERIALS Black powder coated die cast steel
TMPMC-G: Metal (Gooseneck)
TMPMC-R: Chrome plated steel (Z-shaped rod)
FEATURES 360-degree adjustable 3/8" rod eye bolt mount
TMPMC: Strong clamp secures to any drum set or percussion rim
TMPMC-G: Removable flexible microphone gooseneck; Strong clamp secures to any drum set or percussion rim
TMPMC-R: Removable Z-shaped 3/8" rod to mount percussion instruments

STICKS, BEATERS, BRUSHES, MALLETS & SCRAPERS



Bass Beat Cajon Brush
CB4

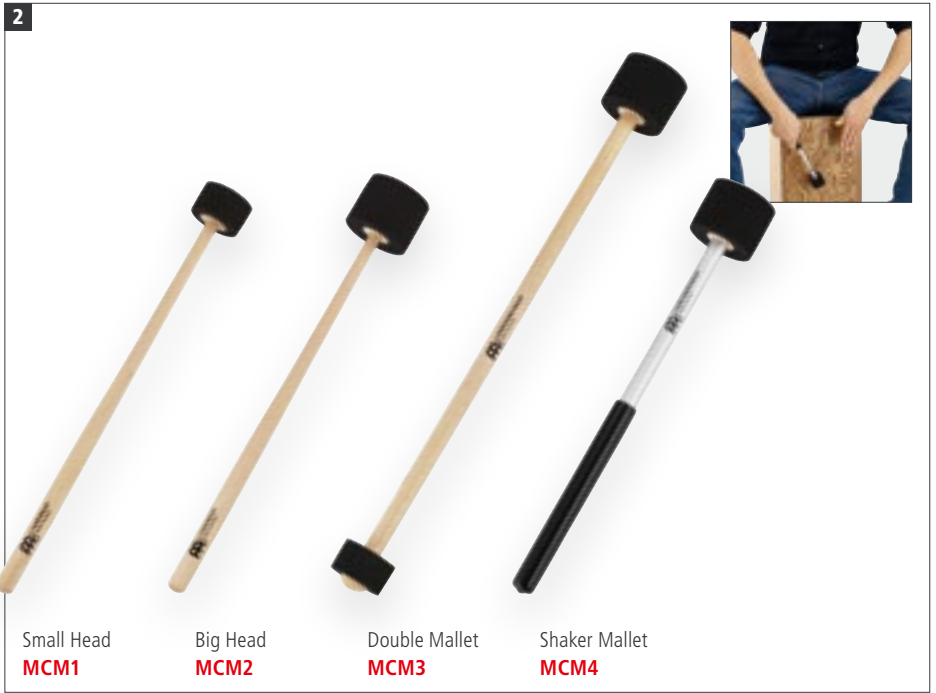

Small Head **MCM1** Big Head **MCM2** Double Mallet **MCM3** Shaker Mallet **MCM4**



Black **TBRS-BK** Red **TBRS-R**



FDT1
FDT2
FDT3
FDT4
FDT5



Long **SST1-L** Medium **SST1-R** Short **SST1-S** Triple **SST3** Triple short **SST3-S**

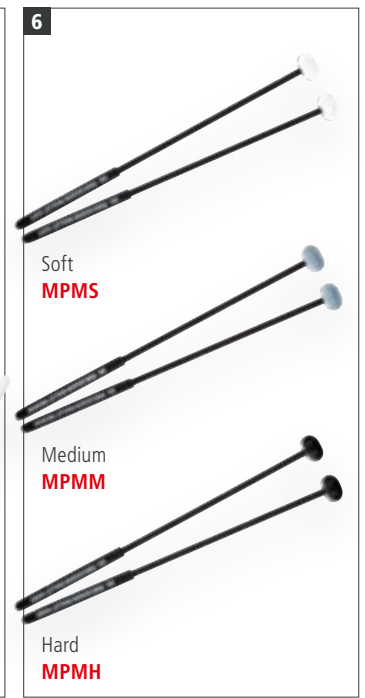

Soft **MPMS**
Medium **MPMM**
Hard **MPMH**

1 BASS BEAT CAJON BRUSH

SIZE 13" long
MATERIALS Polymer bristles
Foam rubber
FEATURES Straight polymer bristles for ultra-smooth precision; Soft foam rubber for full-bodied low notes; Two adjustable control rings; Flexible handle

2 CAJON MALLET COLLECTION

SIZES **MCM1, MCM4:** 11 3/4" long
MCM2: 12 1/4" long
MCM3: 15 1/2" long
MATERIALS Foam rubber
MCM1, MCM2, MCM3: Hard maple
MCM4: Aluminum
FEATURES Made in Germany
MCM1: Made out of the finest hand-selected maple; Small foam rubber head; Designed for softer playing
MCM2: Made out of the finest hand-selected maple; Extra thick foam rubber head
MCM3: Made out of the finest hand-selected maple; Foam rubber padding; Two different ends for contrasting sounds
MCM4: Integrated shaker effect in handle; Soft foam rubber head; Lightweight aluminum handle

3 TAMBORIM STICKS

MATERIAL Synthetic
COLOURS **BK:** Black
R: Red

4 BODHRAN TIPPERS

MATERIAL Ash Wood
COLOUR Antique Brown

5 SAMBA STICKS

SIZES **SST1-S:** Stick, short version
SST1-R: Stick, medium version
SST1-L: Stick, long version
SST3-S: Triple stick, short version
SST3: Triple stick
MATERIAL Synthetic

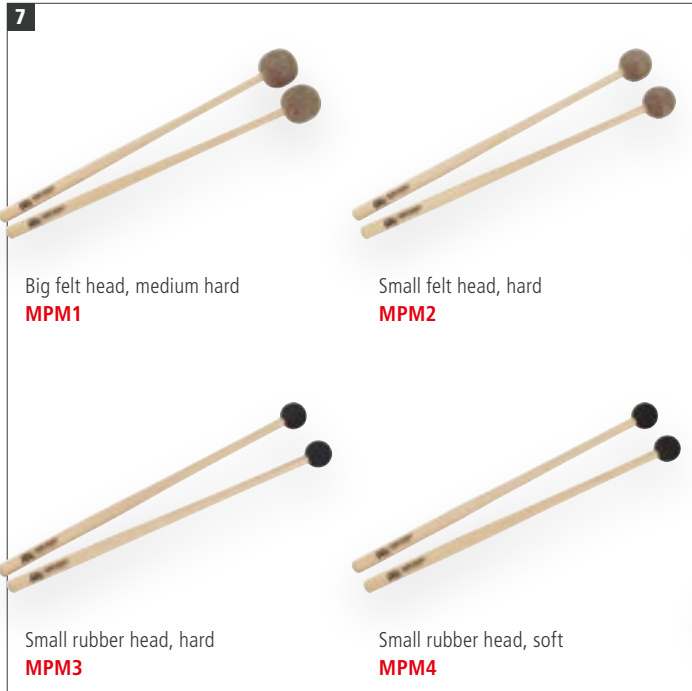

Big felt head, medium hard
MPM1

Small felt head, hard
MPM2

Small rubber head, hard
MPM3

Small rubber head, soft
MPM4



American Hickory
MPM5



High-strength synthetic
COW5



Siam Oak
COW1

Molded ABS
COW3BK

Siam Oak
COW1BK

Siam Oak
COW2

PADDED
BEATER
SECTION



2" felt beater
SB1

2" felt beater
SB2

2 1/2" felt beater
SB3

2" leather beater
SB4

3" bushy felt beater
SB5



SBH

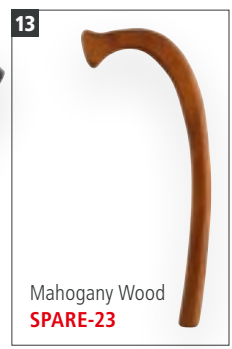

Mahogany Wood
SPARE-23



Wood
MGS1

ABS
MGS2

6 MOLDED ABS PERCUSSION MALLETS

SIZE 12 1/4" long
MATERIAL Durable molded ABS
FEATURES Easy to play across many different percussion instrument types
MPMS: Soft
MPMM: Medium
MPMH: Hard

7 PERCUSSION MALLETS

SIZE 12 1/2" long
MATERIALS Hard maple
MPM1: Big felt head, medium hard
MPM2: Small felt head, hard
MPM3: Small rubber head, hard
MPM4: Small rubber head, soft
FEATURES Made out of the finest hand-selected maple; Great for woodblocks and synthetic percussion blocks; Made in Germany

8 TEMPLE & WOOD BLOCK MALLETS

SIZE 12 1/2" long
MATERIAL American Hickory
FEATURES Soft rubber mallet heads for wood blocks; Solid hickory handles

9 PALO COWBELL BEATER

SIZE 9 1/2" long
MATERIAL High-strength synthetic
FEATURES Cutting tone; High-strength; Balanced weight; Rubber grip; For live and studio

10 COWBELL BEATERS

MATERIALS **COW1, COW2:** Siam Oak (*Hevea brasiliensis* Muell.-Arg.)
COW3: Molded ABS
FEATURES Ribbed grip; Durable construction

11 SAMBA BEATERS

SIZES **SB1:** 15" long
SB2, SB3, SB4, SB5: 16" long
MATERIALS **SB1:** Aluminum stick with 2" felt beater
SB2: Wood stick with 2" felt beater
SB3: Wood stick with 2 1/2" felt beater
SB4: Wood stick with 2" leather beater
SB5: Wood stick with 3" bushy felt beater

12 SURDO BEATER HOLDER

MATERIAL Leather
COLOUR Black

13 TALKING DRUM BEATER

MATERIAL Mahogany Wood

14 GÜIRA SCRAPERS

MATERIALS Steel rods
MGS1: Ergonomic wooden grip
MGS2: Sanded ABS grip

BAGS



BAGS

MATERIAL Heavy-duty nylon (unless noted otherwise)

1 CAJON GIG BAG

SIZE 20 1/2" W x 12" H x 12" D

FEATURE Carrying grip

2 PROFESSIONAL CAJON BAGS

SIZES **MCJB:** 20 1/2" W x 12" H x 12" D

MCJB-L: 23 1/2" W x 17" H x 15" D

FEATURES Padded shoulder strap; External pocket; Carrying grip

MCJB-L: Fits bigger sized cajons

3 DELUXE CAJON BAG

SIZE 20 1/2" W x 12" H x 12" D

FEATURES Synthetic fur; Padded shoulder strap; External pocket; Carrying grip

4 DELUXE BASS PEDAL CAJON BAG

SIZE 21 1/2" W x 17" H x 14 1/2" D

FEATURES Synthetic fur; Padded shoulder strap; External pocket; Carrying grip

5 CAJON BACKPACK

SIZE 13 1/2" W x 19 3/4" H x 14" D

FEATURES Backpack; Carrying grip

6 JAM CAJON GIG BAG

SIZE 12" W x 16" H x 12" D

FEATURES Fits all Jam Cajon models; Strong carrying grip; Two-way zipper

7 TRAVEL CAJON GIG BAG

SIZE 12"

FEATURES Double-slide zipper; Carrying grip

8 PROFESSIONAL SLAPTOP CAJON BAG

SIZE 23" W x 15" H x 13" D

FEATURES Padded shoulder strap; External pocket; Carrying grip

9 CAJON & CAIXONET BAG

SIZE 31" W x 12 1/2" H x 13 1/2" D

FEATURES Carrying handle with reinforced nylon stitching; Durable zipper; Adjustable shoulder strap; Fits caiXoN and caiXoNet stacked or individual

FEATURES Padded shoulder strap; Carrying grip

10 PROFESSIONAL HYBRID SLAPTOP CAJON BAG

SIZE 17 1/2" W x 13" H x 8" D

MSTDJB10 **MSTDJB12**
STANDARD DJEMBE BAGS

MDJB-S **MDJB-M** **MDJB-L** **MDJB-XL**
PRO DJEMBE BAGS

MSTDJB
DJEMBE GIG BAG

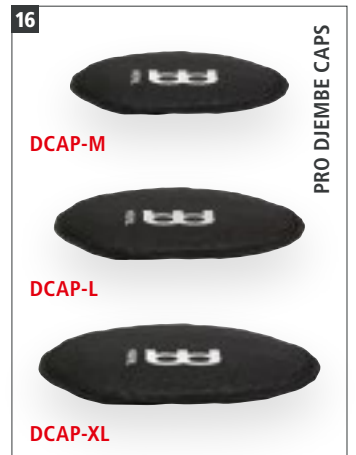
VR-DJB-9 **VR-DJB-10** **VR-DJB-12** **VR-DJB-14**
POP OFF DJEMBE BAGS

DCAP-M
DCAP-L
DCAP-XL
PRO DJEMBE CAPS

MSTCOB
CONGA GIG BAG

MCOB-11 **MCOB-1134** **MCOB-1212**
PRO CONGA BAGS

VR-CSETB
POP OFF CONGA SET BAG
11 MULTI-PERCUSSION BAG

SIZE 21" W x 12" H x 15" D
FEATURES Padded shoulder strap; External pocket; Carrying grip; Padded dividers

12 STANDARD DJEMBE BAGS

SIZES **MSTDJB10**: Medium (10")
MSTDJB12: Large (12")
FEATURES External pocket; Carrying grip

13 PROFESSIONAL DJEMBE BAGS

SIZES **S**: Small (up to 10")
M: Medium (up to 12")
L: Large (up to 13 1/2")
XL: XL: Extra large (up to 14")
FEATURES External pocket; Carrying grip
MDJB-M, MDJB-L, MDJB-XL: Padded backpack straps

14 DJEMBE GIG BAG

FEATURES Carrying grip; Shoulder strap; Outer pocket

15 POP OFF DJEMBE BAGS

SIZES **VR-DJB-9**: 11 1/2" x 17 1/4"
VR-DJB-10: 11 3/4" x 19 3/4"
VR-DJB-12: 13 3/4" x 24 1/2"
VR-DJB-14: 15 3/4" x 27 1/2"
FEATURES Carrying handle with reinforced nylon stitching; Durable zipper; Adjustable backpack straps
VR-DJB-9 Holds 8" & 9" diameter djembes
VR-DJB-10 Holds 10" diameter djembes
VR-DJB-12 Holds 12" diameter djembes
VR-DJB-14 Holds 14" diameter djembes

16 PROFESSIONAL DJEMBE CAPS

SIZES **M**: 10"; **L**: 12"; **XL**: 13"

17 CONGA GIG BAG

FEATURES Carrying grip; Shoulder strap; Outer pocket

18 PROFESSIONAL CONGA BAGS

SIZES **MCOB-11**: 11"
MCOB-1134: 11 3/4"
MCOB-1212: 12 1/2"
FEATURES Additional upright zipper; External pocket; Padded backpack straps; Carrying grip

19 POP OFF CONGA SET BAG

SIZE 13" x 26"
FEATURES Carrying handle with reinforced nylon stitching; Durable zipper; Adjustable backpack straps; Carry all three sizes of Meinl Pop Off Congas

BAGS



BAGS

MATERIAL Heavy-duty nylon (unless noted otherwise)

1 BONGO GIG BAG

SIZE Bongos up to 7 1/2" Macho & 8 1/2" Hembra
FEATURE Carrying grip

2 PROFESSIONAL BONGO BAG

FEATURES Additional room for accessories; Padded shoulder strap; Carrying grip; Padded separator

3 PROFESSIONAL TIMBALES BAG

SIZE 14" & 15"
FEATURES External pocket for stand and cowbell; Padded shoulder strap; Carrying grip; Padded separator

4 PROFESSIONAL SURDO BAGS

SIZES **MSUB-16:** 16" x 20"
MSUB-18: 18" x 22"
MSUB-20: 20" x 24"
MSUB-22: 22" x 24"
FEATURES Double-slide zipper; Padded backpack straps; Carrying grip; External pocket

5 PROFESSIONAL TIMBA BAGS

SIZES **MTIMB-1428:** 14" x 28"
MTIMB-1435: 14" x 35"
FEATURES Double-slide zipper; Padded backpack straps; Carrying grip; External pocket

6 STACK DRUM SET BAG

SIZE 13 1/2" x 24 1/2"
FEATURES Carrying handle with reinforced nylon stitching; Durable zipper; Adjustable backpack straps; Carry both sizes of Meinl Stack Drum Set

7 POP OFF BASS DRUM SET BAG

SIZE 16 1/4" x 25 1/4"
FEATURES Carrying handle with reinforced nylon stitching; Durable zipper; Adjustable backpack straps; Carry all three sizes of Meinl Pop Off Bass Drums

8 PROFESSIONAL TANTAM BAG

SIZE 14" x 28"
FEATURES Double-slide zipper; Padded backpack straps; Carrying grip; External pocket

9 PROFESSIONAL REBOLO BAG

SIZE 12" x 18"
FEATURES Double-slide zipper; Padded shoulder strap; Carrying grip; External pocket

10 PROFESSIONAL REPINIQUE BAGS

SIZES **MREB-10:** 10" x 10"
MREB-12: 12" x 12"



FEATURES Double-slide zipper; Shoulder strap; Carrying grip; External pocket

11 PROFESSIONAL CUICA BAGS

SIZES **MQW-6:** 6"
MQW-10: 10"

FEATURES Padded shoulder strap; Carrying grip; External pocket

12 PROFESSIONAL CAIXA BAGS

SIZES **MCA-12:** 12" x 4 1/2"
MCA-12T: 12" x 6"
MCA-14: 14" x 4"

FEATURES Double-slide zipper; Shoulder strap; Extra pocket for spare heads; Carrying grip; External pocket

13 PROFESSIONAL CHIMES BAG

FEATURES Stores up to 2 chimes; Carrying grip; Inner hook and loop fastener straps;

2 internal pockets

14 PROFESSIONAL FRAME DRUM BAGS

SIZES **MFDB-14:** 14", 2 1/2" deep
MFDB-16: 16", 2 1/2" deep
MFDB-18: 18", 2 1/2" deep
MFDB-20: 20", 2 1/2" deep
MFDB-22: 22", 2 1/2" deep

FEATURES Double-slide zipper; Shoulder strap; Carrying grip

15 PROFESSIONAL DEEP SHELL FRAME DRUM BAGS

SIZES **MFDB-12BE:** 12" x 4"
MFDB-14BE: 14" x 4"
MFDB-14IBO: 14" x 6"
MFDB-18BO: 18" x 4"
MFDB-22-D: 22" x 4"

FEATURES Double-slide zipper; Shoulder strap; Carrying grip

16 PROFESSIONAL PANDEIRO BAGS

SIZES **MPAB-10:** 10"; **MPAB-12:** 12"

FEATURES Double-slide zipper; Shoulder strap; External pocket
MPAB-12: Also fits for our 10" Tambourines

17 TAMBOURINE GIG BAG

SIZE 10"
FEATURES Sturdy zipper; Carrying grip

18 PROFESSIONAL TAMBORIM BAG

SIZE 6"
FEATURES Double-slide zipper; Shoulder strap; External pocket

19 PROFESSIONAL KANJIRA BAG

SIZE 8 1/2" x 2 1/2"
FEATURES Double-slide zipper; Shoulder strap; External pocket

BAGS



BAGS

MATERIAL Heavy-duty nylon
(unless noted otherwise)

1 STANDARD DARBUKA BAG

SIZE Medium
FEATURES Carrying grip; Shoulder strap; Outer pocket

2 PROFESSIONAL DARBUKA BAG

FEATURES Double-slide zipper; Additional upright zipper; Padded shoulder strap; Carrying grip; External pocket

3 PROFESSIONAL IBO BAGS

SIZES **S:** Small (9 3/4" W x 13 1/3" H x 9 3/4" D)
M: Medium (11" W x 14 1/2" H x 11" D)
L: Large (11 3/4" W x 15" H x 11 3/4" D)
FEATURES Padded shoulder strap; Carrying grip; External pocket

4 STANDARD DOUMBЕК BAG

SIZE Medium
FEATURES Carrying grip; Shoulder strap; Outer pocket

5 PROFESSIONAL DOUMBЕК BAGS

SIZES **MDOB:** Medium
MDOB-L: Large
FEATURES Double-slide zipper; Additional upright zipper; Padded shoulder strap; Carrying grip; External pocket

6 STRAIGHT DIDGERIDOO BAG

SIZE 53"
FEATURES Padded shoulder strap; External pocket

7 PRO DIDGERIDOO BAG

SIZE 58"
FEATURES Padded shoulder strap; External pocket

8 PERCUSSION BACKPACK

MATERIAL Ripstop Fabric
FEATURES Travel backpack for small percussion instruments; Numerous pockets on the inside and outside; Padded backpack shoulder straps; Carrying grip
FINISH Carbon Grey

9 HAND PERCUSSION BAGS

SIZES **M:** Medium
L: Large
FEATURES Great for cowbells, blocks or small hand percussion; Drawstring top; Durable nylon prevents scuffs and scratches; No hassle storage or travel

10 COMPACT STICK BAG

FEATURE Carrying grip

BAGS & DRUM RUGS



10
COMPACT STICK BAG

MCSB



11
PROFESSIONAL STICK BAG

MSB-1

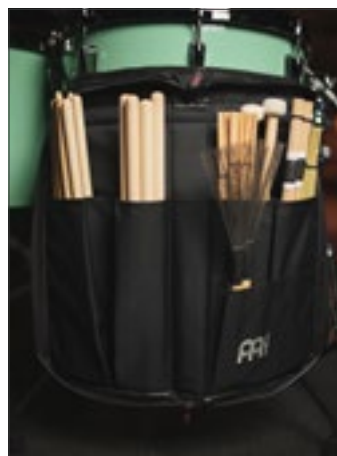

12
DELUXE STICK BAG

MDLXSB



13
STICK SLING BAG

MSSB



14
DRUM RUGS

Black, small
MDRS-BK

Black, large
MDRL-BK

Oriental, small
MDRS-OR

Oriental, large
MDRL-OR

11 PROFESSIONAL STICK BAG

FEATURES External pockets; Shoulder straps; Extension straps
COLOUR Black

12 DELUXE STICK BAG

MATERIAL Padded synthetic leather
FEATURES External pockets; Shoulder straps; Elastic cord attachments

13 STICK SLING BAG

FEATURES Wider version of our Professional Stick Bag; Eleven internal pockets of varying size for any kind of stick, mallet, rod, brush or accessory; Oversized exterior pocket that can fit books, sheet music, practice pads or metronomes

14 DRUM RUGS

SIZES **MDRS:** 5.25 ft (160 cm) x 4.6 ft (140 cm)
MDRL: 6.5 ft (200 cm) x 6.5 ft (200 cm)

MATERIAL Woven fabric

FEATURES **MDRS** Tightly woven fabric creates a strong grip with spurs and stands; Durable no-slip rubber bottom; Compact size for smaller drum or percussion setups; Ideal for smaller stage footprint
MDRL

Durable no-slip rubber bottom; Full-size for any drum or percussion setup; Ideal for drum risers

INCLUDES Travel bag
Strap

FINISHES **BK:** Black
OR: Oriental

MEINL PERCUSSION ONLINE

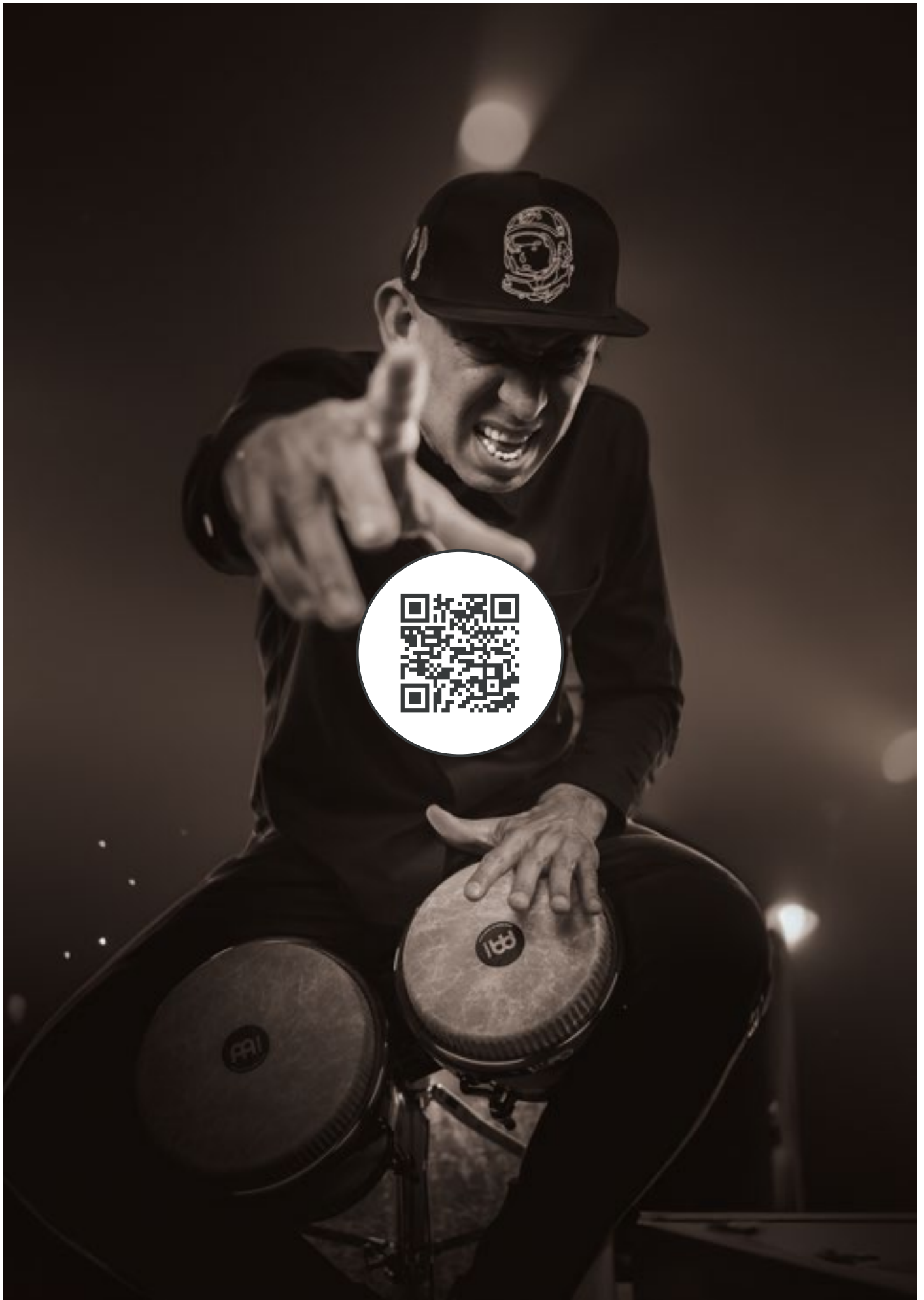

DISCLAIMER

All features are subject to change without notice. Not responsible for typographic errors. No part of this book may be reprinted, reproduced, or included in any online service in any form in whole or in part, without the prior permission of Meinel.

© 2025 Roland Meinel Musikinstrumente GmbH & Co. KG

ADVERTISING CONCEPT & DESIGN

ercas GmbH & Co. KG [ercasdieagentur.de]

CONTENT & DIRECTION

Hannes Auerochs, Udo Heubeck

COPYWRITING

Hannes Auerochs, Ayrton Gauerke

PHOTOGRAPHY

Christian Habermeier, Sebastian Jäger, Angelika Jakobs [studio-waldeck.de]

Miroslav Šmikmátor [smikmatorphoto.com]

Tobias Winklmann, Danny Lucenara, Hannes Auerochs, Manuel Burdeus Mendoza, Jan Potsch, Niklas Sakowski, Thomas Bönig, Paul Höppner, Christian Schemm, Mario Schmitt, William De La Cruz, Dennis Ostermann, Rüdiger Knuth

LITHOGRAPHY

Sven Mihm [mihm-werbung.de]

GLOBAL HEADQUARTERS

Roland Meinel Musikinstrumente GmbH & Co. KG
Musik-Meinel-Straße 1
91468 Gutenstetten
Germany

US HEADQUARTERS

Meinel USA L.C.
3427 Ambrose Avenue
Nashville, TN 37207
USA

INVENTORS OF SELECTED PRODUCTS

Bill Saragosa
Dany Moreno
Gilson Batista Da Silveira
José J. Cortijo
Juan Carlos Melian
Marcus Ralph De Mowbray
Mark Allen Johnson
Michael Buchner
Reiko Guthschmidt
Taku Hirano
Torsten Franz

REMO®, Fiberskyn®, Nuskyn® and Skyndeeep® are registered trademarks of REMO® Inc. Used by permission.

This catalogue has been printed on climate neutral paper.

Printed in Germany M-CA201024

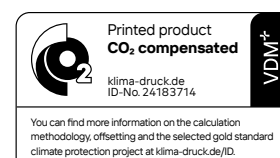

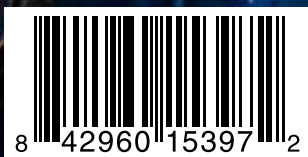

8 42960 15397 2