



THE BOOK OF MEINL PERCUSSION 2026

Daoud DEBU



WE ARE HERE TO INSPIRE

WHAT'S NEW IN 2026

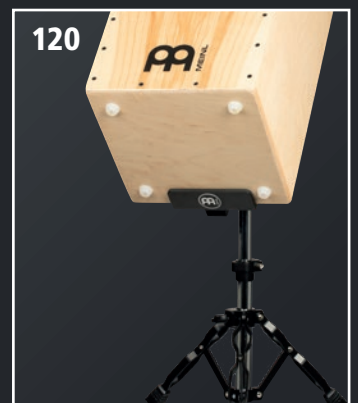
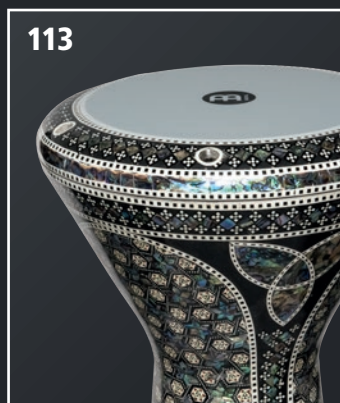
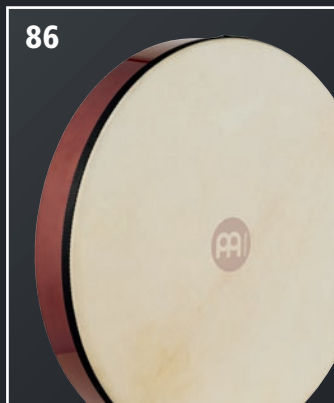



B	
Bags	130
Blocks	42
Bongos	22

C	
Cabasas	43
Cajons	46
Castanets	95
Chimes	98
Claves	40
Congas	06
Cowbells	35
Culture Instruments	113

D	
Darbukas	114
Didgeridoos	100
Djembes	68
Doumbeks	113

F	
Foot Percussion	62
Frame Drums	86

G	
Güiros	40

H	
Hardware	118

K	
Kalimbas	95

M	
Maracas	41
Merenge Güiras	43

R	
Rainsticks	102

S	
Samba	105
Shakers	61/90/105
Sound Effects	96
Sticks/Beaters	128

T	
Tambourines	78/91
Timbales	30

CONGAS

The conga is more than just a drum; it's a vessel of history and emotion. Its story begins in the heart of Africa, where drums were crafted to celebrate and connect communities. Over time, it evolved into a powerful symbol of identity and expression, blending African rhythms with Spanish and indigenous influences. The conga became the heartbeat of Afro-Cuban music.

Meinl Percussion Congas represent tradition combined with exceptional craftsmanship. We produce these premium drums using only the finest hand-selected materials. We collaborate closely with the most sought-after Conga players on a daily basis, drawing on their expertise to fine-tune every aspect of our drums and make sure that we ensure the highest quality sound and performance.

When you hear the deep, resonant tones of a Meinl Percussion Conga, you're not just hearing a drum; you're feeling the rhythm that has connected generations.





CONGA HEADS & SIGNATURE CONGAS

1



The REMO® Symmetry Conga Heads add more volume and resonance to your Conga. These are available for congas with this sign.



Black Calfskin Skyndeeep® **RHEAD-11BK** Black Calfskin Skyndeeep® **RHEAD-1134BK** Black Calfskin Skyndeeep® **RHEAD-1212BK**



Black Calfskin Skyndeeep® **RTHEAD-11BK** Black Calfskin Skyndeeep® **RTHEAD-1134BK** Black Calfskin Skyndeeep® **RTHEAD-1212BK**



Fiberskyn® **RHEAD-11NT** Fiberskyn® **RHEAD-1134NT** Fiberskyn® **RHEAD-1212NT**



Nuskyn® **RTHEAD-11NS** Nuskyn® **RTHEAD-1134NS** Nuskyn® **RTHEAD-1212NS**

2



NEW

TRUE SKIN BUFFALO HEADS



11" **DC11PG** 11 3/4" **DC1134PG** 12 1/2" **DC1212PG**

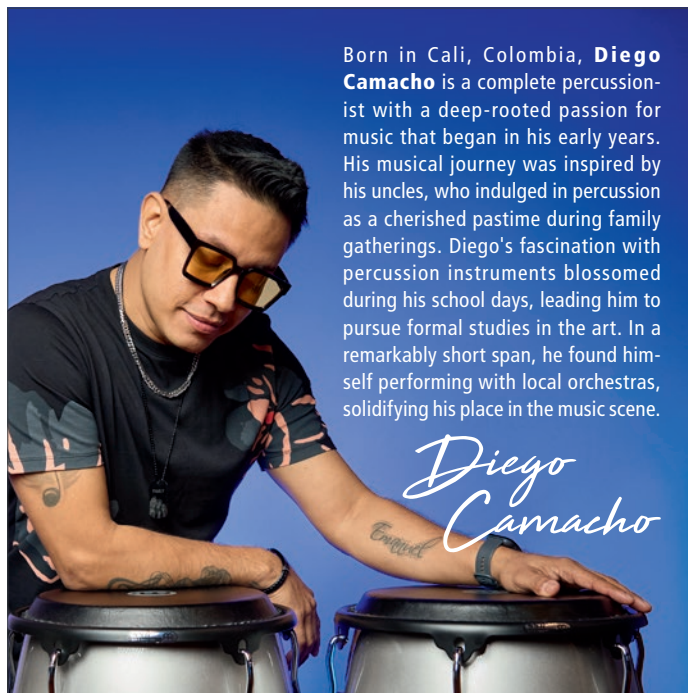

Born in Cali, Colombia, **Diego Camacho** is a complete percussionist with a deep-rooted passion for music that began in his early years. His musical journey was inspired by his uncles, who indulged in percussion as a cherished pastime during family gatherings. Diego's fascination with percussion instruments blossomed during his school days, leading him to pursue formal studies in the art. In a remarkably short span, he found himself performing with local orchestras, solidifying his place in the music scene.

Diego Camacho

1 REMO® SYMMETRY CONGA HEADS

- SIZES** **RHEAD-11:** 11" Quinto; SSR-Rim
RHEAD-1134: 11 3/4" Conga; SSR-Rim
RHEAD-1212: 12 1/2" Tumba; SSR-Rim
RTHEAD-11: 11" Quinto; TTR-Rim
RTHEAD-1134: 11 3/4" Conga; TTR-Rim
RTHEAD-1212: 12 1/2" Tumba; TTR-Rim
- FIT FOR** **RHEAD:** MCC, MEC, MP, FC, MSA, WKT, WCO, BWC, DG, RS, S
RTHEAD: LC, MTC
- FEATURE** For more volume and resonance
- FINISHES** **BK:** Black Calfskin Skyndeeep®
NS: Nuskyn®
NT: Fiberskyn®

2 DIEGO CAMACHO SIGNATURE CONGAS

- SIZES** **DC11:** 11" Quinto, 28" tall
DC1134: 11 3/4" Conga, 28" tall
DC1212: 12 1/2" Tumba, 28" tall
- MATERIALS** Three ply Mango Wood
 True Skin Buffalo Heads, Black
- FEATURES** 10 mm strong tuning lugs
 2.6 mm rounded SSR-Rims
 Black powder coated hardware
- INCLUDES** Meinl Conga Savers
 Meinl Conga Handle
 Meinl Soundpads
 Accessory pouch
 L-shaped tuning key
 Tune Up Oil
- COLOR** **PG:** Pearl Grey

DIEGO CAMACHO SIGNATURE BONGO (SEE PAGE 22)



DC400PG



Born in the city of Pasto, Colombia, **Alexandra Alban** started her musical journey at a very young age. She began as a trumpet player for different groups from her hometown and also pursued singing, where she won several national competitions. It was when she moved to the city of Cali, Colombia, that she began her career as a percussionist. Playing for multiple ensembles and groups around the city, she strengthened her talent as a percussionist and grew as a musician overall.

Alexandra Alban

3

REMO HEADS AVAILABLE

NEW

REMO® FIBERSKYN® HEADS

11"
AA11SY

11 3/4"
AA1134SY

12 1/2"
AA1212SY

CONGAS

4

NEW

TRUE SKIN BUFFALO HEADS

11 3/4"
SG1134M

12"
SG12M

Samuel García Viera, better known as "Sammy García," is a recognized percussionist, musical director and producer from New York City where he started his musical career at the age of 16 years old. Sammy, now based in Puerto Rico, has performed live and in recordings with salsa legends such as Willie Colon, Celia Cruz, Johnny Pacheco, Tito Nieves, Andy Montañez, Marc Anthony, Oscar D'Leon, among others. Sammy García's playing has been heard and seen in venues like Madison Square Garden, Barclays Center, all over the east & west coast, Hawaii, Colombia, Peru, Panama, Ecuador, Dominican República, Chile, Canada, Europe and Japan. He is currently the musical director and conga player for Charlie Aponte.

Sammy García

3 ALEXANDRA ALBAN SIGNATURE CONGAS

SIZES **AA11:** 11" Quinto, 30" tall
AA1134: 11 3/4" Conga, 30" tall
AA1212: 12 1/2" Tumba, 30" tall

MATERIALS Premium fiberglass
 REMO® Fiberskyn® Heads

FEATURES 10 mm strong tuning lugs
 4 mm rounded SSR-Rims
 Brushed nickel hardware

INCLUDES Meinl Conga Savers
 Meinl Conga Handle
 Meinl Soundpads
 Accessory pouch
 L-shaped tuning key
 Tune Up Oil

COLOR **SY:** Sunrise Yellow

4 SAMMY GARCIA SIGNATURE CONGAS

SIZES **SG1134:** 11 3/4" Conga, 28" tall
SG12: 12" Tumba, 28" tall

MATERIALS Premium fiberglass
 True Skin Buffalo Heads

FEATURES 10 mm strong tuning lugs
 4 mm rounded SSR-Rims
 Chrome plated hardware

INCLUDES Meinl Conga Savers
 Meinl Conga Handle
 Meinl Soundpads
 Accessory pouch
 L-shaped tuning key
 Tune Up Oil

DESIGN **M:** La Conga Melodica

ALEXANDRA ALBAN SIGNATURE BONGO
 (SEE PAGE 22)

AA400SY

SIGNATURE CONGAS

1



REMO® BLACK CALFSKIN SKYNDEEP® HEADS

REMO® BLACK CALFSKIN SKYNDEEP® HEADS



11"
WKT11BW

11 3/4"
WKT1134BW

12 1/2"
WKT1212BW



11"
WKT11ES

11 3/4"
WKT1134ES

12 1/2"
WKT1212ES

From Santurce, Puerto Rico, **William "Kachiro" Thompson** was one of the most in-demand conga and bongo players of his time. As a prolific recording and touring artist, Kachiro relied on drums that delivered in a wide variety of musical situations. Whether indoors or outdoors, in an intimate venue or a large stadium, in the studio or on tour, Kachiro sought instruments that felt right in his hands and transmitted the nuances and intensity of his playing. With more than 500 recordings throughout his remarkable career, Kachiro's sound and playing style became a staple in modern salsa music, especially in salsa capitals like San Juan, Miami, and New York. The Artist Series Congas and Bongos by Meinl were the perfect match for Kachiro's vision – both in appearance and sound. Their elegant shape and rich tone accompanied him through countless performances and recordings, always delivering the expressive power he was known for. William "Kachiro" Thompson will be remembered not only for his extraordinary talent but also for his lasting impact on the world of Latin music.

Forever in our hearts.



Kachiro Thompson

1 WILLIAM "KACHIRO" THOMPSON SIGNATURE CONGAS

- SIZES** **WKT11:** 11" Quinto, 30" tall
WKT1134: 11 3/4" Conga, 30" tall
WKT1212: 12 1/2" Tumba, 30" tall
- MATERIALS** REMO® Black Calfskin SkyndeeP® Heads
BW: Three ply New Zealand Pine Wood
ES: Premium Fiberglass
- FEATURES** 10 mm strong tuning lugs
 4 mm rounded SSR-Rims
 Chrome plated hardware
- INCLUDES** Meinl Conga Savers
 Meinl Conga Handle
 Meinl Soundpads
 Accessory pouch
 L-shaped tuning key
 Tune Up Oil
- COLORS** **BW:** Blue Wave
ES: Electric Sky

WILLIAM "KACHIRO" THOMPSON SIGNATURE BONGOS (SEE PAGE 22)



WKT400BW



WKT400ES



Latin Grammy winner, producer, composer, musician and percussionist **Diego Galé** has devoted his artistic life to learning Afro-Cuban music and finding ways to integrate it into his own special style. Diego started playing on bongos at an early age, later adding congas. The Meinl Percussion Diego Galé Artist Series instruments are just what Diego needs in terms of comfort, look, and sound. Their sound is rich and dynamic, full of popping highs and warm lows for both studios and live situations.

Diego Galé

CONGAS

2 **REMO® BLACK CALFSKIN SKYNDEEP® HEADS**

11" **DG11MS** 11 3/4" **DG1134MS** 12 1/2" **DG1212MS**

REMO® FIBERSKYN® HEADS

11" **DGR11CW** 11 3/4" **DGR1134CW** 12 1/2" **DGR1212CW**

2 DIEGO GALÉ SIGNATURE CONGAS

SIZES
DG11: 11" Quinto, 28" tall
DG1134: 11 3/4" Conga, 28" tall
DG1212: 12 1/2" Tumba, 28" tall
DGR11: 11" Quinto, 30" tall
DGR1134: 11 3/4" Conga, 30" tall
DGR1212: 12 1/2" Tumba, 30" tall

MATERIALS
DG: Premium Fiberglass
 REMO® Black Calfskin Skyndeeep® Heads
DGR: Two ply Chamchuri Wood
 REMO® Fiberskyn® Heads

FEATURES
 10 mm strong tuning lugs
 4 mm rounded SSR-Rims
DG: Chrome plated hardware
DGR: Brushed nickel hardware

INCLUDES
 Meinl Conga Savers
 Meinl Conga Handle
 Meinl Soundpads
 Accessory pouch
 L-shaped tuning key
 Tune Up Oil

COLORS
CW: Chamchuri Wood
MS: Midnight Star

FINISH
CW: High gloss

DIEGO GALÉ SIGNATURE BONGOS
(SEE PAGE 23)

DG400MS

DGR400CW

SIGNATURE CONGAS

1 **REMO® FIBERSKYN® HEADS**

REMO HEADS AVAILABLE



11" **RS11PW** 11 3/4" **RS1134PW** 12 1/2" **RS1212PW**



Roberto Serrano is a recognized Mexican percussionist and drummer. His constant search for musical excellence has allowed him the privilege of working with highly recognized musicians, music directors and producers. He is currently on the road with Luis Miguel, considered by Bloomberg and Pollstar to be the #1 tour of 2023-2024, which traveled through North America, Central America, South America, and Europe across 200+ shows.

Roberto Serrano Cruz



Ramon Mongo Santamaria was without a doubt one of the most respected conga players ever, and a pioneer of modern Latin Jazz. Ramon recorded dozens of legendary percussion albums. Mongo has inspired more percussionists around the globe than any other conguero. Mongo Santamaria died at the Baptist Hospital in Miami, USA in February 2003. He was 85 years old. It is with great appreciation and the deepest respect that we honour our friend and his life's work with his Meinl Artist Series Mongo Santamaria Congas.

Ramon Santamaria

2 **TRUE SKIN BUFFALO HEADS**

REMO HEADS AVAILABLE



11" **MSA11AWA** 11 3/4" **MSA1134AWA** 12 1/2" **MSA1212AWA**

1 ROBERTO SERRANO SIGNATURE CONGAS

SIZES **RS11:** 11" Quinto, 30" tall
RS1134: 11 3/4" Conga, 30" tall
RS1212: 12 1/2" Tumba, 30" tall

MATERIALS Three ply Siam Oak
(*Hevea brasiliensis* Muell.-Arg.)
REMO® Fiberskyn® Heads

FEATURES 10 mm strong tuning lugs
4 mm rounded SSR-Rims
Brushed nickel hardware

INCLUDES Meinl Conga Savers
Meinl Conga Handle
Meinl Soundpads
Accessory pouch
L-shaped tuning key
Tune Up Oil

COLOR **PW:** Pearl White

2 RAMON "MONGO" SANTAMARIA SIGNATURE CONGAS

SIZES **MSA11:** 11" Quinto, 30" tall
MSA1134: 11 3/4" Conga, 30" tall
MSA1212: 12 1/2" Tumba, 30" tall

MATERIALS Two ply American White Ash
(*Fraxinus americana* L.)
True Skin Buffalo Heads

FEATURES 10 mm strong tuning lugs
4 mm rounded SSR-Rims
Gold tone hardware

INCLUDES Meinl Conga Savers
Meinl Soundpads
Accessory pouch
L-shaped tuning key
Tune Up Oil

COLOR **AWA:** American White Ash
FINISH High gloss

ROBERTO SERRANO SIGNATURE BONGO (SEE PAGE 23)



RS400PW

3



TRUE SKIN BUFFALO HEADS



11"
LC11NT-M

11 3/4"
LC1134NT-M

12 1/2"
LC1212NT-M

REMO® NUSKYN® HEADS



11"
LCR11NT-M

11 3/4"
LCR1134NT-M

12 1/2"
LCR1212NT-M



Luis Conte's genius stems from his ability to integrate the powerful rhythms of his native Cuba with the needs of American pop music. His long and storied career has included numerous Hollywood film scores and mega-successful albums with Madonna, Ray Charles, Phil Collins, Santana, Shakira, Jackson Browne, Sergio Mendes, Cachao, and a multitude of other artists. All of Luis' needs have been met and exceeded with the Meinl Artist Series Luis Conte Congas. They combine the charm and sound of traditional Cuban drums with modern features and innovations. These congas are equipped with traditional rims that are mounted as close to the shell as possible. When combined with Meinl's True Skin Buffalo Heads, they deliver an even more controlled sound.

CONGAS

3 LUIS CONTE SIGNATURE CONGAS

SIZES **LC(R)11:** 11" Quinto, 30" tall
LC(R)1134: 11 3/4" Conga, 30" tall
LC(R)1212: 12 1/2" Tumba, 30" tall

MATERIALS Two ply Siam Oak
(Hevea brasiliensis Muell.-Arg.)
LC: True Skin Buffalo Heads
LCR: REMO® Nuskyn® Heads

FEATURES 8 mm strong tuning lugs
 5 mm traditional TTR-Rims
 Black powder coated hardware

INCLUDES Meinl Conga Savers
 Meinl Soundpads
 Accessory pouch
 L-shaped tuning key
 Tune Up Oil

COLOR **NT:** Natural
FINISH Matte

LUIS CONTE SIGNATURE BONGOS
 (SEE PAGE 23)



LC300NT-M



LCR300NT-M

SPECTRUM CONGAS

1

REMO
HEADS
AVAILABLE



PHANTOM BLACK

SPECTRUM SERIES HARDWARE



11"
S11PBK

11 3/4"
S1134PBK

12 1/2"
S1212PBK



NENÉ VÁSQUEZ, VENEZUELA

1 SPECTRUM SERIES CONGAS

SIZES S11: 11" Quinto, 30" tall
S1134: 11 3/4" Conga, 30" tall
S1212: 12 1/2" Tumba, 30" tall

MATERIALS Three ply Siam Oak
(*Hevea brasiliensis* Muell.-Arg.)

True Skin Buffalo Heads
FEATURES 10 mm strong tuning lugs
4 mm rounded SSR-Rims
Spectrum Series hardware

INCLUDES Meinl Conga Savers
Meinl Conga Handle
Meinl Soundpads
Accessory pouch
L-shaped tuning key
Tune Up Oil

COLOR PBK: Phantom Black

PROFESSIONAL CONGA STAND WITH WHEELS
(SEE PAGE 119)



TMPC

2 **REMO HEADS AVAILABLE**

VINTAGE BLACK

11" **WCO11VBK-M** 11 3/4" **WCO1134VBK-M** 12 1/2" **WCO1212VBK-M**

VINTAGE BROWN

11" **WCO11VBR-M** 11 3/4" **WCO1134VBR-M** 12 1/2" **WCO1212VBR-M**

VINTAGE RED

11" **WCO11VR-M** 11 3/4" **WCO1134VR-M** 12 1/2" **WCO1212VR-M**

3 **ZEBRA FINISHED ASH**

11" **WC11ZFA-M** 11 3/4" **WC1134ZFA-M** 12 1/2" **WC1212ZFA-M**

2 WOODCRAFT SERIES WCO CONGAS

- SIZES** **WCO11:** 11" Quinto, 30" tall
WCO1134: 11 3/4" Conga, 30" tall
WCO1212: 12 1/2" Tumba, 30" tall
- MATERIALS** Three ply American White Ash (*Fraxinus americana* L.)
 True Skin Buffalo Heads
- FEATURES** 10 mm strong tuning lugs
 4 mm rounded SSR-Rims
 Chrome plated hardware
- INCLUDES** Meinl Conga Savers
 Meinl Conga Handle
 Meinl Soundpads
 Accessory pouch
 L-shaped tuning key
 Tune Up Oil
- COLORS** **VBK-M:** Vintage Black
VBR-M: Vintage Brown
VR-M: Vintage Red
- FINISH** Matte

3 WOODCRAFT TRADITIONAL SERIES CONGAS

- SIZES** **WC11:** 11" Quinto, 30" tall
WC1134: 11 3/4" Conga, 30" tall
WC1212: 12 1/2" Tumba, 30" tall
- MATERIALS** Three ply American White Ash (*Fraxinus americana* L.)
 True Skin Buffalo Heads
- FEATURES** 10 mm strong tuning lugs
 5 mm traditional TTR-Rims
 Chrome plated hardware
- INCLUDES** Meinl Conga Savers
 Meinl Conga Handle
 Meinl Soundpads
 Accessory pouch
 L-shaped tuning key
 Tune Up Oil
- COLOR** Zebra Finished Ash
- FINISH** Matte

CONGA SOUND PLATE (SEE PAGE 119)



CSP

FIBERCRAFT & FLOATUNE CONGAS

1

REMO HEADS AVAILABLE

TRUE SKIN BUFFALO HEADS **REMO® BLACK CALFSKIN SKYNDDEEP® HEADS**



11" **FC11BK** 11 3/4" **FC1134BK** 12 1/2" **FC1212BK** 11" **FCR11BK** 11 3/4" **FCR1134BK** 12 1/2" **FCR1212BK**



2 **NATURAL**



10" **FL10NT** 11" **FL11NT** 12" **FL12NT** 13" **FL13NT**

1 FIBERCRAFT SERIES CONGAS

SIZES **FC(R)11:** 11" Quinto, 30" tall
FC(R)1134: 11 3/4" Conga, 30" tall
FC(R)1212: 12 1/2" Tumba, 30" tall

MATERIALS Premium fiberglass
FC: True Skin Buffalo Heads
FCR: REMO® Black Calfskin Skynddeep® Heads

FEATURES 10 mm strong tuning lugs
 4 mm rounded SSR-Rims
 Chrome plated hardware

INCLUDES Meinl Conga Savers
 Meinl Conga Handle
 Meinl Soundpads
 Accessory pouch
 L-shaped tuning key
 Tune Up Oil

COLOR **BK:** Black

2 FLOATUNE SERIES CONGAS

SIZES **FL10:** 10" Nino, 30" tall
FL11: 11" Quinto, 30" tall
FL12: 12" Conga, 30" tall
FL13: 13" Tumba, 30" tall

MATERIALS Two ply Siam Oak
 (*Hevea brasiliensis* Muell.-Arg.)
 True Skin Buffalo Heads

FEATURES Floatune Tuning System
 10 mm strong tuning lugs
 4 mm rounded SSR-Rims
 Chrome plated hardware

INCLUDES Meinl Conga Savers
 Meinl Conga Handle
 Meinl Soundpads
 Accessory pouch
 L-shaped tuning key
 Tune Up Oil

COLOR Natural
FINISH High gloss

3 PROFESSIONAL SERIES CONGAS

SIZES **MP11:** 11" Quinto, 30" tall
MP1134: 11 3/4" Conga, 30" tall
MP1212: 12 1/2" Tumba, 30" tall

MATERIALS Two ply Siam Oak
 (*Hevea brasiliensis* Muell.-Arg.)
 True Skin Buffalo Heads

FEATURES 10 mm strong tuning lugs
 4 mm rounded SSR-Rims
 Chrome plated hardware

INCLUDES Meinl Conga Savers
 Meinl Conga Handle
 Meinl Soundpads
 Accessory pouch
 L-shaped tuning key
 Tune Up Oil

COLORS **BB:** Brown Burl
NT: Natural

FINISH High gloss

PROFESSIONAL & MINI CONGAS



3

REMO HEADS AVAILABLE

NATURAL

11" **MP11NT**

11 3/4" **MP1134NT**

12 1/2" **MP1212NT**

BROWN BURL

11" **MP11BB**

11 3/4" **MP1134BB**

12 1/2" **MP1212BB**

CONGAS

4

Natural, 4 1/2" **MC100NT**

Vintage Wine Barrel, 4 1/2" **MC100VWB**

Wine Red, 4 1/2" **MC100WR**



5

CONGA-SAVER8

CONGA-SAVER10

6

COMES IN A SET OF 4

Set **MCR-BK**

4 MINI CONGAS

SIZE 4 1/2" wide, 11" tall

MATERIALS Siam Oak (*Hevea brasiliensis* Muell.-Arg.) Buffalo skin heads

FEATURES Contains every feature of a regular Meinl conga, at 2/5 the size Tunable buffalo skin head with 4 chrome lugs and rounded rim Great for spontaneous jam sessions or drum circles

COLORS **NT:** Natural **VWB:** Vintage Wine Barrel **WR:** Wine Red

5 CONGA SAVERS

SIZES **CONGA-SAVER8:** for 8 mm tuning lugs **CONGA-SAVER10:** for 10 mm tuning lugs

FEATURES Placed over the conga lugs to prevent them from damaging and scratching the shell Conga remains fully tunable

6 CONGA RISERS

MATERIAL Sturdy rubber

FEATURES Raise your drums off the floor to allow maximum sound projection Provide a stable base on any surface Come in a set of four Flexible construction

COLOR **BK:** Black

REMO® SYMMETRY CONGA HEADS
(SEE PAGE 06)

REMO HEADS AVAILABLE

The REMO® Symmetry Conga Heads add more volume and resonance to your Conga. These are available for congas with this sign.

Fiberskyn®

Nuskyn®

Black Calfskin Skyndeepp®

MARATHON® CONGAS



MARATHON® SERIES CONGAS

1 2 3 4

PATENTS Steely-II patents:
 L-shaped leg and metal spike attachment (DE, TH, US patent)
 U-shaped notch (US patent)
 Ergonomic arched rubber bracing (CN, DE, TH, US patent)
 Notches for quick height adjustability (DE patent)

1 MARATHON® EXCLUSIVE SERIES CONGAS

SIZES **MEC(R)11:** 11" Quinto, 30" tall
MEC(R)1134: 11 3/4" Conga, 30" tall
MEC(R)1212: 12 1/2" Tumba, 30" tall
MATERIALS **MEC(R)11NT, MEC(R)1134NT, MEC(R)1212NT:** Two ply Siam Oak (Hevea brasiliensis Muell.-Arg.)

MEC11WRP, MEC1134WRP, MEC1212WRP: Two ply New Zealand Pine Wood
MEC: True Skin Buffalo Heads
MECR: REMO® Fiberskyn® Heads
FEATURES 8 mm strong tuning lugs
 2.6 mm rounded SSR-Rims
CH: Chrome plated hardware
G: Gold tone hardware
INCLUDES Steely II Conga Stand (patented)
 Meinl Conga Savers
 Meinl Conga Handle
 Meinl Sound Pads
 Accessory pouch
 L-shaped tuning key
 Tune Up Oil
COLORS **NT:** Natural
WR: Wine Red
FINISH High gloss

2 MARATHON® TRADITIONAL SERIES CONGAS

SIZES **MTCR11:** 11" Quinto, 30" tall
MTCR1134: 11 3/4" Conga, 30" tall
MTCR1212: 12 1/2" Tumba, 30" tall
MATERIALS Two ply Siam Oak (Hevea brasiliensis Muell.-Arg.)
 REMO® Black Calfskin Skyndee® Heads
FEATURES 8 mm strong tuning lugs
 5 mm traditional TTR-Rims
 Black powder coated hardware
INCLUDES Steely II Conga Stand (patented)
 Meinl Conga Savers
 Meinl Conga Handle
 Meinl Sound Pads
 Accessory pouch
 L-shaped tuning key
 Tune Up Oil
COLOR **WR:** Wine Red
FINISH High gloss

2 **REMO HEADS AVAILABLE**

REMO® BLACK CALFSKIN SKYNDDEEP® HEADS

11" **MTCR11WR** 11 3/4" **MTCR1134WR** 12 1/2" **MTCR1212WR**

3 **REMO HEADS AVAILABLE**

TRUE SKIN BUFFALO HEADS

11" **MCC11LB** 11 3/4" **MCC1134LB** 12 1/2" **MCC1212LB**

4 **REMO HEADS AVAILABLE**

NATURAL

11" **MCC11NT** 11 3/4" **MCC1134NT** 12 1/2" **MCC1212NT**

SUPER NATURAL

11" **MCC11SNT-M** 11 3/4" **MCC1134SNT-M** 12 1/2" **MCC1212SNT-M**

COFFEE BURST

11" **MCC11CB** 11 3/4" **MCC1134CB** 12 1/2" **MCC1212CB**

3 MARATHON® DESIGNER SERIES CONGAS

SIZES **MCC11:** 11" Quinto, 30" tall
MCC1134: 11 3/4" Conga, 30" tall
MCC1212: 12 1/2" Tumba, 30" tall

MATERIALS Two ply Siam Oak
(Hevea brasiliensis Muell.-Arg.)
 True Skin Buffalo Heads

FEATURES 8 mm strong tuning lugs
 2.6 mm rounded SSR-Rims
 Black powder coated hardware

INCLUDES Steely II Conga Stand (patented)
 Meinl Conga Savers
 Accessory pouch
 L-shaped tuning key
 Tune Up Oil

COLOR **LB:** Leopard Burl

FINISH High gloss

4 MARATHON® CLASSIC SERIES CONGAS

SIZES **MCC11:** 11" Quinto, 30" tall
MCC1134: 11 3/4" Conga, 30" tall
MCC1212: 12 1/2" Tumba, 30" tall

MATERIALS Two ply Siam Oak
(Hevea brasiliensis Muell.-Arg.)
 True Skin Buffalo Heads

FEATURES 8 mm strong tuning lugs
 2.6 mm rounded SSR-Rims
 Black powder coated hardware

INCLUDES Steely II Conga Stand (patented)
 Meinl Conga Savers
 Accessory pouch
 L-shaped tuning key
 Tune Up Oil

COLORS **CB:** Coffee Burst, high gloss
NT: Natural, high gloss
SNT-M: Super Natural, matte

REMO® SYMMETRY CONGA HEADS
 (SEE PAGE 06)



The REMO® Symmetry Conga Heads add more volume and resonance to your Conga. These are available for congas with this sign.



HEADLINER® CONGAS



1 HEADLINER® SERIES CONGAS

SIZES	HC10: 10" Nino, 28" tall HC11: 11" Quinto, 28" tall HC12: 12" Conga, 28" tall
MATERIALS	Siam Oak (<i>Hevea brasiliensis</i> Muell.-Arg.) Hand selected buffalo heads
FEATURES	8 mm strong tuning lugs Original Meinl style tuning brackets 2 mm rounded rims Black powder coated hardware
INCLUDES	Height adjustable basket stands (patented) with quick set up system Tuning key
COLORS	PBK-M: Phantom Black SNT-M: Super Natural VWB-M: Vintage Wine Barrel
FINISH	Matte

PATENTS	Basket stand patents: Ergo arched rubber bracing (CN, DE, TH, US patent) U-shaped notch (US patent) L-shaped leg (DE patent)
----------------	---

2 HEADLINER® TRADITIONAL SERIES CONGAS

SIZES	HTC10: 10" Nino, 28" tall HTC11: 11" Quinto, 28" tall HTC12: 12" Conga, 28" tall
MATERIALS	Siam Oak (<i>Hevea brasiliensis</i> Muell.-Arg.) Hand selected buffalo heads
FEATURES	8 mm strong tuning lugs Original Meinl style tuning brackets 5 mm traditional TTR-Rims Black powder coated hardware
INCLUDES	Height adjustable basket stands (patented) with quick set up system Tuning key
COLOR	WB-M: Walnut Brown
FINISH	Matte
PATENTS	Basket stand patents: Ergo arched rubber bracing (CN, DE, TH, US patent) U-shaped notch (US patent) L-shaped leg (DE patent)

HEADLINER® CONGA SETS



3



Set, 10" & 11"
HC555NT



Set, 11" & 12"
HC512NT

NATURAL



Set, 10" & 11"
HC555VSB

VINTAGE SUNBURST



Set, 10" & 11"
HC888NT

THE BONGO MOUNT IS EASY MOUNTABLE ON OUR CONGA DOUBLE STANDS (SEE PAGE 119)



THBM



Set, 11" & 12"
HC512VSB



Set, 11" & 12"
HC812NT



Set, 10" & 11"
HC888VSB



Set, 11" & 12"
HC812VSB

3 HEADLINER® SERIES CONGA SETS

- SIZES** **HC555, HC888:**
10" Nino & 11" Quinto, 28" tall
HC512, HC812:
11" Quinto & 12" Conga, 28" tall
- MATERIALS** Siam Oak (*Hevea brasiliensis* Muell.-Arg.)
Hand selected buffalo heads
- FEATURES** 8 mm strong tuning lugs
Original Meinl style tuning brackets
2 mm rounded rims
Black powder coated hardware
- INCLUDES** Tuning key
HC555, HC512: Height adjustable basket stands (patented) with quick set up system
HC888, HC812: Height adjustable double braced tripod stand
- COLORS** **NT:** Natural
VSB: Vintage Sunburst
- FINISH** High gloss

- PATENTS** Basket stand patents:
Ergo arched rubber bracing (CN, DE, TH, US patent)
U-shaped notch (US patent)
L-shaped leg (DE patent)

CONGAS

BONGOS



The bongo drum is a little instrument with a tremendous soul. Its roots can be found in the vibrant streets of Cuba, where indigenous, Spanish, and African sounds blended to create a vibrant musical tapestry. The larger drum, the "hembra", and the smaller drum, the "macho", add vitality to the song by making bright, crisp sounds that cut through the atmosphere.

Meinl bongos are expertly made with a commitment to quality, fusing imagination and accuracy. Our bongos guarantee to enhance each beat and stimulate your musical journey, regardless of your level of experience with drumming – whether you're a beginner learning the art or an accomplished performer honing your craft.



BONGO HEADS & SIGNATURE BONGOS

1

REMO HEADS AVAILABLE

The REMO® R-Series Bongo Heads add more volume and resonance to your Bongo. These are available for bongos with this sign.

Fiberskyn®
RHEAD-7NT

Fiberskyn®
RHEAD-812NT

Nuskyn®
RHEAD-7NS

Nuskyn®
RHEAD-812NS

Black Calfskin Skyndeeep®
RHEAD-7BK

Black Calfskin Skyndeeep®
RHEAD-812BK

2

REMO HEADS AVAILABLE

NEW

Pearl Grey, 7" & 8 1/2"
DC400PG

Diego Camacho

Alexandra Alban

3

REMO HEADS AVAILABLE

NEW

Sunrise Yellow, 7" & 8 1/2"
AA400SY

4

REMO HEADS AVAILABLE

Blue Wave, 7" & 8 1/2"
WKT400BW

Electric Sky, 7" & 8 1/2"
WKT400ES

Kachiro Thompson

1 REMO® R-SERIES BONGO HEADS

SIZES **RHEAD-7:** 7" Macho
RHEAD-812: 8 1/2" Hembra

FIT FOR LC300, FFB400, FWB400, CS400, WB400, BWB400, WKT400, RS400, DG400, S400

FEATURE For more volume and resonance

FINISHES **BK:** Black Calfskin Skyndeeep®;
NS: Nuskyn®; **NT:** Fiberskyn®

2 DIEGO CAMACHO SIGNATURE BONGO

SIZES 7" Macho & 8 1/2" Hembra

MATERIALS Mango Wood
True Skin Buffalo Heads, Black

FEATURES Meinl Free Ride Suspension System;
Black powder coated hardware;
8 mm strong tuning lugs;
3 mm rounded SSR-Rims

INCLUDES Accessory pouch; L-shaped tuning key;
Tune Up Oil

COLOR **PG:** Pearl Grey

3 ALEXANDRA ALBAN SIGNATURE BONGO

SIZES 7" Macho & 8 1/2" Hembra

MATERIALS Premium fiberglass
REMO® Fiberskyn® Heads

FEATURES Meinl Free Ride Suspension System;
Brushed nickel hardware;
8 mm strong tuning lugs;
3 mm rounded SSR-Rims

INCLUDES Accessory pouch; L-shaped tuning key;
Tune Up Oil

COLOR **SY:** Sunrise Yellow

4 WILLIAM "KACHIRO" THOMPSON SIGNATURE BONGOS

SIZES 7" Macho & 8 1/2" Hembra

MATERIALS **WKT400BW:** New Zealand Pine Wood
WKT400ES: Premium Fiberglass
REMO® Black Calfskin Skyndeeep® Heads

FEATURES Meinl Free Ride Suspension System;
Chrome plated hardware; 8 mm strong
tuning lugs; 3 mm rounded SSR-Rims;
Resonance Shaping Area

INCLUDES Accessory pouch; L-shaped tuning key;
Tune Up Oil

COLORS **BW:** Blue Wave
ES: Electric Sky



Midnight Star, 7" & 8 1/2"
DG400MS

Natural, high gloss, 7" & 8 1/2"
DGR400CW



Diego Galé



Roberto Serrano Cruz

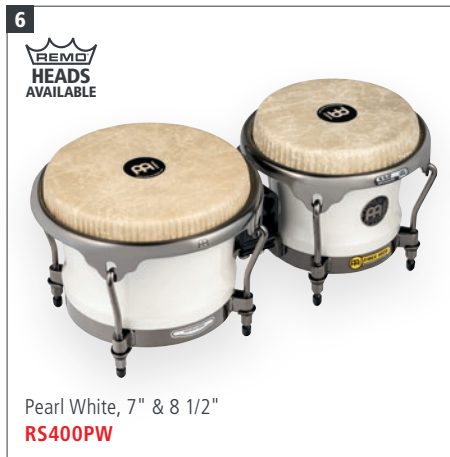

Pearl White, 7" & 8 1/2"
RS400PW



Natural, matte, 6 3/4" & 8"
LC300NT-M

Natural, matte, 6 3/4" & 8"
LCR300NT-M



Luis Conte

5 DIEGO GALÉ SIGNATURE BONGOS

- SIZES** 7" Macho & 8 1/2" Hembra
- MATERIALS** **DG400MS:** Premium Fiberglass
REMO® Black Calfskin Skyndee® Heads
DGR400CW: Chamchuri Wood
REMO® Fiberskyn® Heads
- FEATURES** Meinl Free Ride Suspension System;
8 mm strong tuning lugs; 3 mm rounded
SSR-Rims; Resonance Shaping Area
DG400MS: Chrome plated hardware
DGR400CW: Brushed nickel hardware
- INCLUDES** Accessory pouch; L-shaped tuning key;
Tune Up Oil
- COLORS** **CW:** Natural, high gloss
MS: Midnight Star

6 ROBERTO SERRANO SIGNATURE BONGO

- SIZES** 7" Macho & 8 1/2" Hembra
- MATERIALS** Siam Oak (*Hevea brasiliensis* Muell.-Arg.)
REMO® Fiberskyn® Heads
- FEATURES** Meinl Free Ride Suspension System;
Brushed nickel hardware; 8 mm strong
tuning lugs; 3 mm rounded SSR-Rims;
Resonance Shaping Area
- INCLUDES** Accessory pouch; L-shaped tuning key;
Tune Up Oil
- COLOR** **PW:** Pearl White

7 LUIS CONTE SIGNATURE BONGOS

- SIZES** 6 3/4" Macho & 8" Hembra
- MATERIALS** Siam Oak (*Hevea brasiliensis* Muell.-Arg.)
LC300NT-M: True Skin Cow Heads
LCR300NT-M: REMO® Nuskyn® Heads
- FEATURES** Solid woodblock connection; Black
powder coated hardware; 8 mm strong
tuning lugs; 5 mm traditional TTR-Rims
- INCLUDES** Accessory pouch; L-shaped tuning key;
Tune Up Oil
- COLOR** **NT-M:** Natural, matte

BONGOS

1

REMO
HEADS
AVAILABLE



Phantom Black, 7" & 8 1/2"
S400PBK

2



Antique Mahogany Burst, high gloss, 7" & 9"
WB500AMB

CHROME PLATED 5 MM TRADITIONAL TTR RIM



Zebra Finished Ash, matte, 7" & 9"
WB500ZFA-M

3

REMO
HEADS
AVAILABLE



Vintage Black, matte, 7" & 8 1/2"
WB400VBK-M



Vintage Brown, matte, 7" & 8 1/2"
WB400VBR-M



Vintage Red, matte, 7" & 8 1/2"
WB400VR-M

4

REMO
HEADS
AVAILABLE



Natural, 7" & 8 1/2"
BWB400

5

REMO
HEADS
AVAILABLE



Black, 7" & 8 1/2"
FFB400BK

PREMIUM FIBERGLASS



Black, 7" & 8 1/2"
FFBR400BK

1 SPECTRUM SERIES BONGO

SIZES 7" Macho & 8 1/2" Hembra
MATERIALS Siam Oak (*Hevea brasiliensis* Muell.-Arg.)
True Skin Cow Heads
FEATURES Meinl Free Ride Suspension System;
Spectrum Series hardware; 8 mm strong
tuning lugs; 3 mm rounded SSR-Rims
INCLUDES Accessory pouch; L-shaped tuning key;
Tune Up Oil
COLOR **PBK**: Phantom Black

2 WOODCRAFT SERIES WB500 WOOD BONGOS

SIZES 7" Macho & 9" Hembra
MATERIALS American White Ash
(*Fraxinus americana* L.)
True Skin Cow Heads

FEATURES Meinl Free Ride Suspension System;
Chrome plated hardware; 8 mm strong
tuning lugs; 5 mm traditional TTR-Rims;
Resonance Shaping Area
INCLUDES Accessory pouch; L-shaped tuning key;
Tune Up Oil
COLORS **AMB**: Antique Mahogany Burst, high gloss
ZFA-M: Zebra Finished Ash, matte

3 WOODCRAFT SERIES WB400 WOOD BONGOS

SIZES 7" Macho & 8 1/2" Hembra
MATERIALS American White Ash
(*Fraxinus americana* L.)
True Skin Cow Heads
FEATURES Meinl Free Ride Suspension System;
Chrome plated hardware; 8 mm strong
tuning lugs; 3 mm rounded SSR-Rims;
Resonance Shaping Area

INCLUDES Accessory pouch; L-shaped tuning key;
Tune Up Oil
COLORS **VBK-M**: Vintage Black, matte
VBR-M: Vintage Brown, matte
VR-M: Vintage Red, matte

4 WOODCRAFT SERIES BWB400 WOOD BONGO

SIZES 7" Macho & 8 1/2" Hembra
MATERIALS European Birch (*Betula pendula*)
Hand selected cow heads
FEATURES Meinl Free Ride Suspension System;
Chrome plated hardware; 8 mm strong
tuning lugs; 3 mm rounded SSR-Rims;
Resonance Shaping Area; Natural finish
European Birch shells
INCLUDES Accessory pouch; L-shaped tuning key;
Tune Up Oil
COLOR Natural

6

REMO HEADS AVAILABLE



Natural, high gloss, 7" & 8 1/2"
FWB400NT



Brown Burl, high gloss, 7" & 8 1/2"
FWB400BB



Cherry Red, high gloss, 7" & 8 1/2"
FWB400CR

7

CHROME PLATED ROUNDED SSR RIM

GOLD TONE ROUNDED SSR RIM



Gold Amber Sunburst, high gloss, 7" & 8 1/2"
FWB400GAB



Natural, 6 3/4" & 8"
WB200NT-CH



Natural, 6 3/4" & 8"
WB200NT-G

8

TRADITIONAL TTR-RIM

REMO HEADS AVAILABLE



Wine Red, 6 3/4" & 8"
WBTR300WR



CHROME PLATED ROUNDED SSR RIM



Super Natural, 6 3/4" & 8"
WB200SNT-M

5 FIBERCRAFT SERIES FIBERGLASS BONGOS

SIZES 7" Macho & 8 1/2" Hembra
MATERIALS Premium fiberglass
FFB400BK: True Skin Cow Heads
FFBR400BK: REMO® Black Calfskin Skyndee® Heads
FEATURES Meinl Free Ride Suspension System; Chrome plated hardware; 8 mm strong tuning lugs; 3 mm rounded SSR-Rims; Resonance Shaping Area
INCLUDES Accessory pouch; L-shaped tuning key; Tune Up Oil
COLOR **BK:** Black

FEATURES Meinl Free Ride Suspension System; Chrome plated hardware; 8 mm strong tuning lugs; 3 mm rounded SSR-Rims; Resonance Shaping Area
INCLUDES Accessory pouch; L-shaped tuning key; Tune Up Oil
COLORS **BB:** Brown Burl, high gloss
CR: Cherry Red, high gloss
GAB: Gold Amber Sunburst, high gloss
NT: Natural, high gloss

INCLUDES Accessory pouch; L-shaped tuning key; Tune Up Oil
COLORS **NT:** Natural, high gloss
SNT-M: Super Natural, matte

6 PROFESSIONAL SERIES WOOD BONGOS

SIZES 7" Macho & 8 1/2" Hembra
MATERIALS Siam Oak (*Hevea brasiliensis* Muell.-Arg.) True Skin Cow Heads

7 WB200 WOOD BONGOS

SIZES 6 3/4" Macho & 8" Hembra
MATERIALS Siam Oak (*Hevea brasiliensis* Muell.-Arg.) Hand selected buffalo heads
FEATURES Solid woodblock connection; 8 mm strong tuning lugs; 2 mm rounded SSR-Rims
WB200NT-CH: Chrome plated hardware
WB200NT-G: Gold tone hardware
WB200SNT-M: Chrome plated hardware

8 TRADITIONAL SERIES BONGO

SIZES 6 3/4" Macho & 8" Hembra
MATERIALS Siam Oak (*Hevea brasiliensis* Muell.-Arg.) REMO® Black Calfskin Skyndee® Heads
FEATURES Solid woodblock connection; Black powder coated hardware; 8 mm strong tuning lugs; 5 mm traditional TTR-Rims
INCLUDES Accessory pouch; L-shaped tuning key; Tune Up Oil
COLOR **WR:** Wine Red, high gloss

BONGOS



Natural, 6 3/4" & 8"
FWB200NT



Gold Amber Sunburst, 6 3/4" & 8"
FWB200GAB



Leopard Burl, 6 3/4" & 8"
FWB190LB



Natural, 6 3/4" & 8"
FWB190NT



Super Natural, 6 3/4" & 8"
FWB190SNT-M



Amber Flame, 6 3/4" & 8"
FWB190AF



Antique Tobacco Burst, 6 3/4" & 8"
FWB190ATB-M



Wine Red, 6 3/4" & 8"
WB200WRP-CH



Natural, 6 3/4" & 8"
HB100NT



Vintage Sunburst, 6 3/4" & 8"
HB100VSB



Wine Red Burst, 6 3/4" & 8"
HB100WRB



Vintage Wine Barrel, 6 3/4" & 8"
HB100VWB-M

1 MARATHON® EXCLUSIVE SERIES FWB200 WOOD BONGOS

SIZES 6 3/4" Macho & 8" Hembra
MATERIALS Siam Oak (*Hevea brasiliensis* Muell.-Arg.)
Hand selected buffalo heads
FEATURES Meinl Free Ride Suspension System;
Chrome plated hardware; 8 mm strong
tuning lugs; 2 mm rounded SSR-Rims
COLORS **GAB**: Gold Amber Sunburst, high gloss
NT: Natural, high gloss

2 MARATHON® DESIGNER SERIES FWB190 WOOD BONGOS

SIZES 6 3/4" Macho & 8" Hembra
MATERIALS Siam Oak (*Hevea brasiliensis* Muell.-Arg.)
Hand selected buffalo heads
FEATURES Meinl Free Ride Suspension System;
Black powder coated hardware;
8 mm strong tuning lugs; 2.5 mm
rounded SSR-Rims; Unique designs

COLORS **AF**: Amber Flame, high gloss
LB: Leopard Burl, high gloss

3 MARATHON® SERIES FWB190 WOOD BONGOS

SIZES 6 3/4" Macho & 8" Hembra
MATERIALS Siam Oak (*Hevea brasiliensis* Muell.-Arg.)
Hand selected buffalo heads
FEATURES Meinl Free Ride Suspension System;
Black powder coated hardware;
8 mm strong tuning lugs;
2 mm rounded SSR-Rims
COLORS **ATB-M**: Antique Tobacco Burst, matte
NT: Natural, high gloss
SNT-M: Super Natural, matte

4 MARATHON® EXCLUSIVE SERIES WB200 WOOD BONGO

SIZES 6 3/4" Macho & 8" Hembra
MATERIALS New Zealand Pine Wood
Hand selected buffalo heads
FEATURES Solid woodblock connection; Chrome
plated hardware
INCLUDES Accessory pouch; L-shaped tuning key;
Tune Up Oil
COLOR **WR**: Wine Red, high gloss

5 HEADLINER® SERIES HB100 WOOD BONGOS

SIZES 6 3/4" Macho & 8" Hembra
MATERIALS Siam Oak (*Hevea brasiliensis* Muell.-Arg.)
Hand selected buffalo heads
FEATURES Black powder coated hardware; 8 mm
strong tuning lugs; 2 mm rounded rims
for playing comfort; Interior backing
plates



Walnut Brown, 6 3/4" & 8"
HTB100WB-M

TRADITIONAL TTR-RIM



Black, 6 3/4" & 8"
HFB100BK

PREMIUM FIBERGLASS



Set, 4 pcs.
BPP-1

WITH JOURNEY
SERIES HB50BK BONGO

BONGOS



Black, 6 1/2" & 7 1/2"
HB50BK



Ultimate Grey, 6 1/2" & 7 1/2"
HB50UG



Bright White, 6 1/2" & 7 1/2"
HB50WH



Flamingo Pink, 6 1/2" & 7 1/2"
HB50FP



Red, 6 1/2" & 7 1/2"
HB50R



Electric Coral, 6 1/2" & 7 1/2"
HB50EC



Creamsicle, 6 1/2" & 7 1/2"
HB50CS



Illuminating Yellow, 6 1/2" & 7 1/2"
HB50IY



Forest Green, 6 1/2" & 7 1/2"
HB50FG



Seafoam Green, 6 1/2" & 7 1/2"
HB50SF



Glacier Blue, 6 1/2" & 7 1/2"
HB50GB



Super Natural, matte, 3 1/2" & 4 1/4"
FWB100SNT-M

MINI!

- INCLUDES Tuning key
- COLORS **NT:** Natural, high gloss
VSB: Vintage Sunburst, high gloss
VWB-M: Vintage Wine Barrel, matte
WRB: Wine Red Burst, high gloss

6 HEADLINER® SERIES HTB100 WOOD BONGO

- SIZES 6 3/4" Macho & 8" Hembra
- MATERIALS Siam Oak (*Hevea brasiliensis* Muell.-Arg.)
Hand selected buffalo heads
- FEATURES Black powder coated hardware;
8 mm strong tuning lugs; 5 mm strong
TTR-Rims; Interior backing plates
- INCLUDES Tuning key
- COLOR **WB-M:** Walnut Brown, matte

7 HEADLINER® SERIES HFB100 FIBERGLASS BONGO

- SIZES 6 3/4" Macho & 8" Hembra
- MATERIALS Premium fiberglass
Hand selected buffalo heads
- FEATURES Black powder coated hardware; 8 mm
strong tuning lugs; 2.6 mm rounded rims
- INCLUDES Tuning key
- COLOR **BK:** Black

8 BONGO & PERCUSSION PACK

- CONTAINS Journey Series HB50BK Bongo; Compact
Foot Tambourine; Luis Conte Live Shaker;
Classic Wood Claves

9 JOURNEY SERIES HB50 BONGOS

- SIZES 6 1/2" Macho & 7 1/2" Hembra
- MATERIALS Molded ABS
Hand selected buffalo heads

- FEATURES Black powder coated hardware;
Rounded rims for playing comfort
- INCLUDES Tuning key
- COLORS **BK:** Black; **CS:** Creamsicle; **EC:** Electric
Coral; **FG:** Forest Green; **FP:** Flamingo
Pink; **GB:** Glacier Blue; **IY:** Illuminating
Yellow; **R:** Red; **SF:** Seafoam Green;
UG: Ultimate Grey; **WH:** Bright White

10 MINI WOOD BONGO

- SIZES 3 1/2" Macho & 4 1/4" Hembra
- MATERIALS Siam Oak (*Hevea brasiliensis* Muell.-Arg.)
True Skin Buffalo Heads
- FEATURES Meinl Free Ride Suspension System;
2 mm rounded SSR-Rims
- INCLUDES Tuning key
- COLOR **SNT-M:** Super Natural, matte

TIMBALES



The Timbales originated in the center of the Caribbean, where life's rhythms pulsate through the atmosphere like a constant heartbeat. These drums were originally played in small, private gatherings. Over time, their sleek, attractive shells and resonant tones increased their influence in the music industry as timbaleros innovated bold new rhythms. Still popular today, timbales are being incorporated into an ever-increasing number of musical genres as they continue to develop. Meinl Timbales are as inventive and one-of-a-kind as the artists that contributed to their design and creation. We collaborate closely with the world's best timbaleros on a daily basis, ensuring that these instruments continue to serve as a symbol of lively tradition, inventive music, and a testament to the Caribbean's rich cultural legacy.



SIGNATURE TIMBALES

1

NEW



Bronze,
14" & 15"
PD1415



Patricio "El Chino" Díaz is a Cuban-born timbalero from Camagüey, Cuba, renowned for his expressive solos and deep command of Afro Cuban rhythm. A disciple of legendary percussionist Changuito, he's acclaimed for his innovative approach to timbales, blending traditional techniques with a modern improvisational flair.



Manolito Rodriguez is an outstanding professional percussionist originally from Caguas, Puerto Rico. A graduate of the Puerto Rico Conservatory of Music, his musical career began at an early age, when he joined the group Haciendo Punto en Otro Son. At the age of 12, he was recognized at the 1998 National Salsa Day with the Roberto Roena y Su Apollo Sound Orchestra. His first significant achievement came at the age of 14, when he participated in the recording of the song "Paz para Vieques" with flutist Néstor Torres, which was nominated for a Latin Grammy.

Manolito Rodriguez



Atomic Red,
14" & 15"
MR1415

3



Antique bronze,
14" & 15"
AV1ABR



Grammy winner artist **Amadito Valdés** has been playing music for more than 60 years. His first teachers were his father, Amado Valdes, and Walfredo de los Reyes Sr., two undeniable masters. In 1997, he joined the "Buena Vista Social Club," whose eponymous album won a 1998 Grammy award. Amadito's work with famed piano player Rubén Gonzalez and the Afro Cuban All Stars orchestra, along with his appearance in the documentary "Buena Vista Social Club," has made him the "most seen timbalero" behind the legendary Tito Puente.

Amadito Valdés

1 PATRICIO "EL CHINO" DIAZ SIGNATURE TIMBALES

SIZES 14" & 15"
MATERIALS Bronze
Black synthetic heads
FEATURES Chrome plated hardware
Classic cascara sound
INCLUDES Professional Timbale Stand
Adjustable cowbell holder
Accessory pouch
L-shaped tuning key
Tune Up Oil
COLOR Bronze

2 MANOLITO RODRIGUEZ SIGNATURE TIMBALES

SIZES 14" & 15"
MATERIALS Steel
Black synthetic heads
FEATURES Black nickel hardware
Easy-Tuning System
INCLUDES Professional Timbale Stand
L-shaped tuning key
Tune Up Oil
FINISH Atomic Red

3 AMADITO VALDÉS SIGNATURE TIMBALES

SIZES 14" & 15"
MATERIAL Steel
Clear synthetic heads
FEATURES Two worked-in flanges
Floatune Tuning System
Logo applied from underneath the head (CN, TH, US patent)
INCLUDES Height adjustable tilting double braced tripod stand
Adjustable cowbell holder
Accessory pouch
L-shaped tuning key
Tune Up Oil
COLOR Antique bronze



Black Diamond,
14" & 15"
DC1415



Diego Camacho



Diego Galé



Solid brass,
14" & 15"
DG1415



Stainless steel,
14" & 15"
LC1STS



Luis Conte

4 DIEGO CAMACHO SIGNATURE TIMBALES

- SIZES** 14" & 15"
- MATERIALS** Steel
Black synthetic heads
- FEATURES** Black nickel hardware
Heavy-duty-style brackets
- INCLUDES** Professional Timbale Stand
L-shaped tuning key
Tune Up Oil
- FINISH** Black Diamond

5 DIEGO GALÉ SIGNATURE TIMBALES

- SIZES** 14" & 15"
- MATERIAL** Solid brass
Clear synthetic heads
- FEATURES** Classic Timbales shape and look
Logo applied from underneath the head (CN, TH, US patent)
- INCLUDES** Professional Timbale Stand
Adjustable cowbell holder
Accessory pouch
L-shaped tuning key
Tune Up Oil

6 LUIS CONTE SIGNATURE TIMBALES

- SIZES** 14" & 15"
- MATERIAL** Stainless steel
Clear synthetic heads
- FEATURES** Two worked-in flanges
Cuban style flared out bottom edge
Logo applied from underneath the head (CN, TH, US patent)
- INCLUDES** Height adjustable tilting double braced tripod stand
Adjustable cowbell holder
Accessory pouch
L-shaped tuning key
Tune Up Oil

TIMBALES



Spectrum,
14" & 15"
ST1415



Brass,
14" & 15"
MTS1415B



Black nickel,
14" & 15"
MTS1415BN



Chrome,
14" & 15"
MTS1415CH



Antique Finish,
14" & 15"
MTS1415RR-M

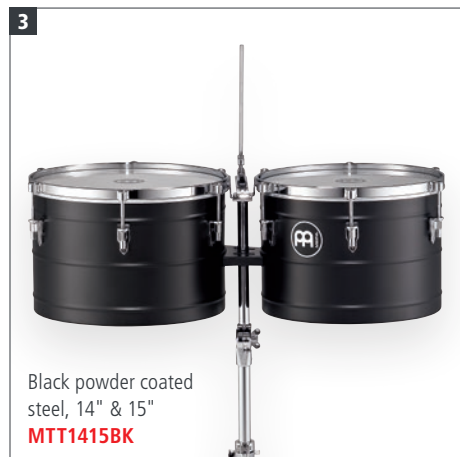

Black powder coated
steel, 14" & 15"
MTT1415BK



Chrome,
13" & 14"
HT1314CH



DESIGNED FOR A UNIQUE LOOK

15" **TBLH15BK** 13" **TBLH13BK** 8" **TBLH8BK**
14" **TBLH14BK** 10" **TBLH10BK** 6" **TBLH6BK**

1 SPECTRUM SERIES TIMBALES

SIZES 14" & 15"
MATERIALS Steel
Black synthetic heads
FEATURES Spectrum Series hardware;
Easy-Tuning System
INCLUDES Professional Timbale Stand; L-shaped
tuning key; Tune Up Oil
FINISH Spectrum

2 MARATHON® SERIES TIMBALES

SIZES 14" & 15", 6.5" deep
MATERIAL Steel
FEATURES Two worked-in flanges; Heavy-duty style
brackets; Logo applied from underneath
the head (CN, TH, US patent)
INCLUDES Adjustable cowbell holder; Height
adjustable tilting double braced tripod
stand; Accessory pouch; L-shaped tuning
key; Tune Up Oil

FINISHES **B:** Brass
BN: Black nickel
CH: Chrome
RR-M: Antique Finish, matte

3 MARATHON® SERIES TURBO TIMBALES

SIZES 14" & 15", 10" deep
MATERIAL Black powder coated steel
FEATURES Three worked-in flanges; Heavy-duty
style brackets; Logo applied from under-
neath the head (CN, TH, US patent)
INCLUDES Adjustable cowbell holder; Height
adjustable tilting double braced tripod
stand; Accessory pouch; L-shaped tuning
key; Tune Up Oil
COLOR **BK:** Black

4 HEADLINER® SERIES TIMBALES

SIZES 13" & 14"
MATERIAL Steel

FEATURES Logo applied from underneath the head
(CN, TH, US patent); Two worked-in flanges
INCLUDES Height adjustable tilting double braced
tripod stand; Tuning key; Wrench;
Cowbell holder
FINISH Chrome

5 TIMBALES HEADS

SIZES **TBLH6BK:** 6"
TBLH8BK: 8" (Mini Timbales Head)
TBLH10BK: 10" (Mini Timbales Head)
TBLH13BK: 13"
TBLH14BK: 14"
TBLH15BK: 15"
MATERIAL Synthetic head
FEATURES Cutting and clean tone with effortless
response; Extremely durable
COLOR Black

SIGNATURE HAND-BALE & DRUMMER TIMBALES



6 SPECIAL DESIGNED RIM

Black powder coated steel, 13"
MHT13BK

Taku Hirano, one of the most in-demand percussionists of his generation – a musical chameleon onstage and in-studio, whether supporting iconic artists or fronting his own projects. He has worked with everyone from Stevie Wonder to Stevie Nicks, Dr. Dre to Dr. John, and referred to by Mick Fleetwood, founder and drummer for Fleetwood Mac, as his "Secret Weapon."

Taku Hirano

TIMBALES

7

Spectrum, 6"
SMDT6

8

Spectrum, 6" & 8"
SMT68

Spectrum, 8" & 10"
SMT810

9 SNARE WIRES ARE ABSOLUTELY QUIET AND CHATTER-FREE IN THE "OFF" POSITION

Black powder coated steel, 6"
MDST6BK

Black powder coated steel, 8"
MDST8BK

Black powder coated steel, 10"
MDST10BK

10

Chrome, 8" & 10"
MIT810CH

Chrome, 13"
MDT13CH

6 TAKU HIRANO SIGNATURE HAND-BALE

SIZE 13"
MATERIAL Black powder coated steel
Clear synthetic heads
FEATURE Logo applied from underneath the head (CN, TH, US patent)
INCLUDES L-shaped tuning key
Tune Up Oil
COLOR **BK**: Black, high gloss

7 SPECTRUM SERIES DRUMMER SNARE TIMBALE

SIZE 6"
MATERIALS Steel
Black timbale head
FEATURES Top-Tuning System; Quick snare on/off system; Chrome hardware
INCLUDES Drum Key
FINISH Spectrum

8 SPECTRUM SERIES DRUMMER MINI TIMBALES

SIZES **SMT68**: 6" & 8"
SMT810: 8" & 10"
MATERIALS Steel
Black timbales heads
FEATURE Chrome hardware
INCLUDES L-shaped tuning key; Tune Up Oil
FINISH Spectrum

9 DRUMMER SNARE TIMBALES

SIZES **MDST6**: 6"
MDST8: 8"
MDST10: 10"
MATERIALS Black powder coated steel
MDST6BK: Black timbales head

FEATURES **MDST6BK**
Top-Tuning System; Quick snare on/off system
MDST8BK, MDST10BK
Quick snare on/off system; Chatter-free "off" position; Logo applied from underneath the head (CN, TH, US patent)
INCLUDES **MDST6BK**: Drum Key
MDST8BK, MDST10BK:
L-shaped tuning key; Tune Up Oil
COLOR **BK**: Black

10 DRUMMER TIMBALE & MINI TIMBALES

SIZES **MDT13CH**: 13" (Drummer Timbale)
MIT810CH: 8" & 10" (Mini Timbales)
MATERIAL Steel
FEATURE Logo applied from underneath the head (CN, TH, US patent)
INCLUDES L-shaped tuning key; Tune Up Oil

COWBELLS



The cowbell, a versatile and distinctive percussion instrument, carries a rich and fascinating history. Born as a humble bell for livestock, it transcended its origins to become a vital part of musical traditions around the world. Its true essence shines most brightly in the passionate rhythms of Latin percussion. Played with a wooden stick, the cowbell anchors the rhythm section and keeps the group in sync.

Meinl offers a wide range of cowbells in various sizes and tunings, each crafted to produce unique and expressive sounds. We collaborate closely with our artists to fulfill their every need, ensuring that every player finds the perfect rhythm and tone. Whether it's the sharp accent in a rock beat or the heartbeat of a Latin ensemble, Meinl's cowbells bring passion and precision to every performance.

SIGNATURE COWBELLS



COWBELLS



Anika Nilles built up a name for herself over the last six years as a Youtube sensation, boasting almost 20 million views on her drum videos featuring original compositions, as well as being a solo artist touring through Europe, China, and North America.

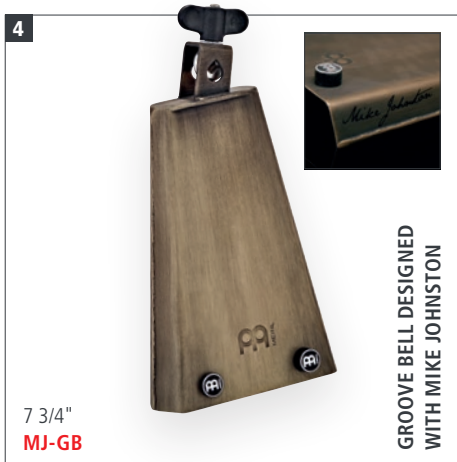
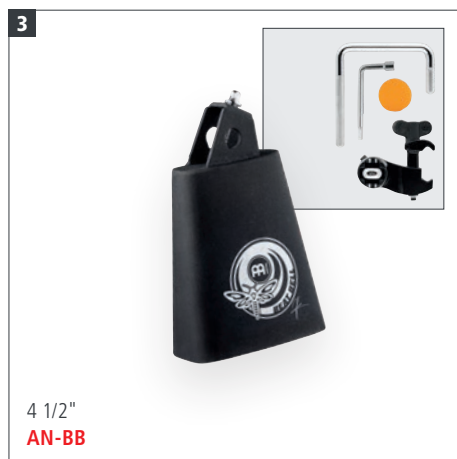

1 MANOLITO RODRIGUEZ SIGNATURE ANTIQUE MAMBO COWBELL

SIZE 8" (Mambo Cowbell)
MATERIAL Special steel alloy
FEATURES Designed with Manolito Rodriguez
 Deep pitch and dry overtones
FINISH Antique

2 DIEGO GALÉ SIGNATURE ROYAL COWBELLS

SIZES **DG-RTB**: 8" (Timbale Cowbell)
DG-RCCB: 5" (Cha Cha Cowbell)
MATERIAL Special steel alloy
FEATURES Designed with Diego Galé
DG-RTB: Deep pitch and dry overtones
DG-RCCB: High pitched and bright sound
FINISH Royal Gold

3 ANIKA NILLES SIGNATURE COWBELL, BEAT BELL

SIZE 4 1/2"
MATERIAL Special steel alloy
FEATURES Attaches directly to your snare
 No stand required
INCLUDES Rim clamp; U-shaped rod; Drum Honey; Drum key

4 MIKE JOHNSTON SIGNATURE COWBELL, GROOVE BELL

SIZE 7 3/4"
MATERIAL Special steel alloy
FEATURE Specifically made for drum set use
INCLUDES Two magnets (one small and one large, based on Benny Greb's Magnetic Sustain Control idea)
FINISH Vintage Steel

PERCUSSION BLOCKS (SEE PAGE 42)



MPE5NG MPE3BK MPE4R MPE4BK

COWBELLS

1 BLACK POWDER COATED STEEL

8" **HCO2BK**
5" **HCO4BK**

2 BLACK POWDER COATED STEEL

8 1/2" **SL850-BK**
6 3/4" **SL675-BK**
5 1/4" **SL525-BK**
4 3/4" **SL475-BK**

3 EASY MOUNTABLE

2 1/2", 3 1/2", 5" **SLTRI-BK**

4 CLASSIC ROCK COWBELL

7" big mouth, low pitch **SCL70B-BK**
8 1/2" low pitch **SCL850-BK**
7" high pitch **SCL70-BK**

5 NEW NEW

8 1/2", C-Tuning **SMBC**
7 1/2", G-Tuning **SMBG**

6 HIGH POLISHED CHROME

8" big mouth **STB80B-CH**
8" small mouth **STB80S-CH**
7 1/2" **STB750-CH**
6 1/4" **STB625-CH**
5 1/2" **STB55-CH**
4 1/2" low pitch **STB45L-CH**

6 HAND BRUSHED STEEL

8" big mouth **STB80B**
8" small mouth **STB80S**
6 1/4" **STB625**
5 1/2" **STB55**
4 1/2" low pitch **STB45L**
4 1/2" medium pitch **STB45M**
4 1/2" high pitch **STB45H**

COWBELLS 1 – 11

MATERIAL Special steel alloy

1 HEADLINER® SERIES COWBELLS

SIZES **HCO2BK**: 8" (Timbales Cowbell)
HCO4BK: 5" (Cha Cha Cowbell)

FEATURE Muffled sound
FINISH **BK**: Black powder coated

2 BLACK FINISH COWBELLS

SIZES **SL850-BK**: 8 1/2" (Timbales Cowbell)
SL675-BK: 6 3/4" (Medium Timbales Cowbell)
SL525-BK: 5 1/4" (Cha Cha Cowbell)
SL475-BK: 4 3/4" (Mini Cha Cha Cowbell)

FEATURE Muffled sound
FINISH **BK**: Black powder coated

3 TRIPLE BELL

SIZES 2 1/2", 3 1/2", 5"

FEATURE Muffled sound
FINISH **BK**: Black powder coated

4 STEEL CRAFT LINE COWBELLS

SIZES **SCL70B-BK**: 7" (Classic Rock Cowbell Big Mouth)
SCL850-BK: 8 1/2" (Timbalero Cowbell)
SCL70-BK: 7" (Timbalero Cowbell)

FEATURES Steel alloy controls overtones and resonance; Classic cowbell sound for any setting
FINISH **BK**: Black powder coated

5 MOUNTABLE SALSA COWBELLS

SIZES **SMBC**: 8 1/2"; **SMBG**: 7 1/2"

TUNING **SMBC**: C; **SMBG**: G
FEATURES Steel alloy controls overtones and resonance; Classic timbales cowbell sound

6 CHROME & STEEL FINISH COWBELLS

SIZES **STB80B**: 8" (Timbales Cowbell Big Mouth)
STB80S: 8" (Timbales Cowbell Small Mouth)
STB750: 7 1/2" (Salsa Timbales Cowbell)
STB625: 6 1/4" (Medium Timbales Cowbell)
STB55: 5 1/2" (Cha Cha Cowbell)
STB45L: 4 1/2" (Low Cha Cha Cowbell)
STB45M: 4 1/2" (Medium Cha Cha Cowbell)
STB45H: 4 1/2" (High Cha Cha Cowbell)

FEATURE Tonally matched
FINISHES Hand brushed steel
CH: High polished chrome

7 HAMMERED COWBELLS

SIZES **STB80BHH**: 8" (Timbales Cowbell Big Mouth)



<p>7</p> <p>HAND BRUSHED GOLD</p> <p>8" big mouth STB80BHH-G</p> <p>6 1/4" STB625HH-G</p>	<p>HAND BRUSHED STEEL</p> <p>8" big mouth STB80BHH-S</p> <p>6 1/4" STB625HH-S</p>	<p>HAND BRUSHED COPPER</p> <p>8" big mouth STB80BHH-C</p> <p>6 1/4" STB625HH-C</p>
---	--	---

8

8 1/2", C-Tuning
SHBC

7 1/2", G-Tuning
SHBG

9

8"
BCOB

BLACK POWDER COATED STEEL

10

8 1/4"
STB815H

7 3/4"
STB785H

6 1/2"
STB65H

11

COMFORTABLE HOLDER

6 1/4"
STB625HA-CB

4 1/2"
STB45HA-CB

12 **NEW**

5 1/2"
MGB

GRAVITY BELL

13

PALO COWBELL BEATER
(SEE PAGE 129)

COW5

13

Magnetic Sustain Control
MCT

BASED ON BENNY GREB'S IDEA

14

Drum Honey Slab
MDHS

15

A DROP OF HONEY MAKES YOUR DRUMS AND CYMBALS SOUND SWEET

Drum Honey
MDH

Drum Honey Assortment
MDHA

16

Medium
MPCC-M

Large
MPCC-L

<p>STB625HH: 6 1/4" (Medium Timbales Cowbell)</p> <p>FEATURE Hammered</p> <p>FINISHES C: Hand brushed copper G: Hand brushed gold S: Hand brushed steel</p>	<p>11 HANDHELD COWBELLS</p> <p>SIZES STB625HA-CB: 6 1/4" STB45HA-CB: 4 1/2"</p> <p>FEATURE Comfortable holder</p> <p>FINISH Hand brushed steel</p>	<p>14 DRUM HONEY SLAB</p> <p>SIZE 3.54" x 2.36" x 0.31"</p> <p>FEATURES Extra thick rectangular dampening gel pad; Creates a super meaty drum tone</p>
<p>8 HANDHELD SALSA BONGO COWBELLS</p> <p>SIZES SHBC: 8 1/2"; SHBG: 7 1/2"</p> <p>TUNING SHBC: C; SHBG: G</p>	<p>12 GRAVITY BELL</p> <p>SIZE 5 1/2"</p> <p>FEATURES Heavyweight metal bell 2.75 lbs (1.250 gr); Dampens drums; Unique metal effects</p> <p>FINISH Black</p>	<p>15 DRUM HONEY</p> <p>CONTAINS MDH: 1 pack of Drum Honey (6 pcs.) MDHA: 12-piece Drum Honey Assortment (6 x small, 4 x medium, 2 x large)</p> <p>FEATURES Transforms your drum sound into a warm and sweet tone with no effort; The gels can be removed and reused as needed; Washable and non-toxic</p>
<p>9 BONGO COWBELL</p> <p>SIZE 8" (Medium Handheld Cowbell)</p> <p>FEATURES Muffled sound; For low volume playing</p> <p>FINISH Black powder coated</p>	<p>13 MAGNETIC SUSTAIN CONTROL</p> <p>CONTAINS 2 x Light dampening magnets (16 x 4 mm) 2 x Heavy dampening magnets (16 x 9 mm)</p> <p>FEATURE Easily control the sustain and dampen the tone of your cymbals or cowbells</p> <p>INCLUDES Storage container</p>	<p>16 COWBELL CUSHIONS</p> <p>SIZES MPCC-M: Medium (32 gr) MPCC-L: Large (70 gr)</p> <p>FEATURES Instantly turn your cowbell sound into a retro, super-dry effect; No adhesive material required</p>

LATIN INSTRUMENTS



Discover the vibrant world of Latin hand percussion instruments, where rhythm and culture come together. Our collection features a variety of traditional instruments like maracas, güiros, claves, cabaças and many more, perfect for adding authentic Latin flavor to your music. Whether you're a professional musician or a hobbyist, these instruments bring warmth, energy, and versatility to any performance. Explore the craftsmanship and history behind each piece, and elevate your sound with the rich percussive beats of Latin America.

PANDEROS DE PLENA & BARRILS DE BOMBA



1 NEW

BAG INCLUDED

10" **PL10CW** 12" **PL12CW** 14" **PL14CW**

Rooted in the soulful rhythms of Puerto Rico's plena tradition, our Pandero de Plena drums are crafted with care and cultural respect. Made from high-quality Chamchuri wood, each drum features a warm, responsive cow head, traditional chrome-plated hardware, and precise J-hook tension rods. Available in classic Requinto, Punteador, and Seguidor sizes, each drum is sold individually for flexible ensemble building.

Celebrate the vibrant rhythms of Puerto Rican tradition with our handcrafted Barriles, available in both Primo and Buleador sizes. Designed for authenticity and durability, each drum features a robust 2-ply Chamchuri wood shell, hand-selected goatskin head, and traditional hardware that pays homage to folkloric craftsmanship. Sold individually and perfect for traditional and performance settings alike.

2 NEW

BAG INCLUDED

14" **BB14CW-CH** 16" **BB16CW-CH**

1 PANDEROS DE PLENA

- SIZES** **PL10:** 10" Requinto
PL12: 12" Punteador
PL14: 14" Seguidor
- MATERIALS** Chamchuri Wood
Hand selected cow skin head
- FEATURES** Traditional tone and feel
Durable Chrome plated hardware
Crafted with care and cultural respect
- INCLUDES** Bag
- COLOR** Antique Brown

2 BARRILS DE BOMBA

- SIZES** **BB14:** 14" Primo, 26" tall
BB16: 16" Buleador, 26" tall
- MATERIALS** Two ply Chamchuri Wood
Hand selected goat skin head
- FEATURES** Traditional rim for classic playability
Durable 2-ply Chamchuri Wood staves
Decorative metal bands add visual appeal
- INCLUDES** Bag
- COLOR** Antique Brown

GÜIROS & CLAVES



1 TURBO GÜIRO

MATERIAL High strength plastic
FEATURES Three striking surfaces;
Rubber ringed grip holes
INCLUDES Synthetic scraper

2 FIBERGLASS GÜIROS

MATERIAL Premium fiberglass
FEATURES Three striking surfaces; Padded grip holes
INCLUDES **GU7BK**: Synthetic scraper
GU7BR: Wooden scraper
COLORS **BK**: Black
BR: Brown

3 WOOD GÜIRO

MATERIAL Wood
FEATURE Grip holes
INCLUDES Wooden scraper
COLOR **AM**: Amber

4 LATIN RHYTHM CLAVES

SIZE 8" & 7" long
MATERIAL Select Hardwood
FEATURES For foundational latin rhythms;
Solid body construction; Traditional look

5 WOOD CLAVES, CLASSIC

MATERIALS **HW**: Hardwood
RW: Select Hardwood
FEATURE Solid body

6 WOOD CLAVES, AFRICAN

MATERIALS **HW**: Hardwood
RW: Select Hardwood
FEATURES **CL2**: Solid body
CL3: Hollowed out body

7 WOOD CLAVES, TRADITIONAL

SIZE 8" long and 1" diameter
MATERIAL **IW**: Indian Walnut
FEATURE Classic pitch and clear, piercing attack

8 CLAVES DE LUXE

SIZE 6 3/4" long
MATERIAL Dense hardwood
FEATURES Cutting sound; Convenient carrying

MARACAS

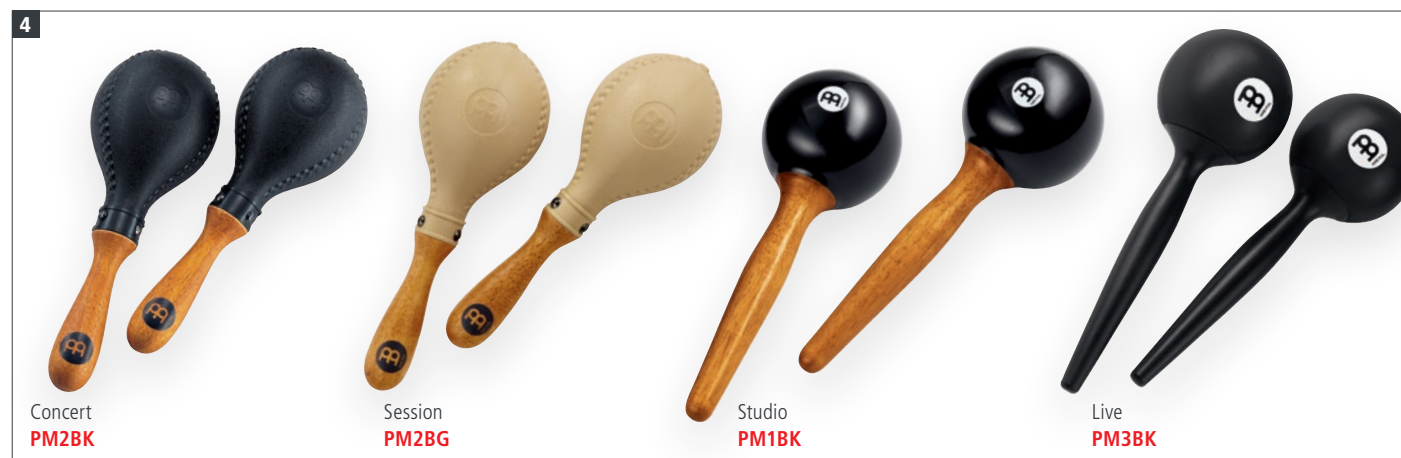

1 RAWHIDE MARACAS

SIZES **MSM2:** Mini
MSM3: Traditional
MSM4: Jumbo

MATERIALS Natural rawhide and wooden handle

FEATURES Entirely made by hand
Offers a wide sonic range
Durable construction

DESIGNS **CO:** Colombia flag
CU: Cuba flag
MX: Mexico flag

2 WOOD MARACAS

MATERIAL Wood

FEATURES Produces a traditional warm and rich sound
Available in both round and oval models

3 PLASTIC EGG MARACAS

SIZE 6"

MATERIAL Synthetic

FEATURE Ergonomically shaped handle

4 CONCERT, SESSION, STUDIO & LIVE MARACAS

MATERIAL Synthetic heads

FEATURE Ergonomically shaped handle

COLORS **BG:** Beige
BK: Black



BLOCKS



Set, 5 pcs.
TMSTB



High pitch **MPE5NG** Medium pitch **MPE3BK** Low pitch **MPE4R** Low pitch **MPE4BK**



Set, 5 pcs.
TMWTB



TMWB-XS **TMWB-S** **TMWB-L**



COMBINATION WOOD BLOCK AND HAND CLAP EFFECT

MWBHC



WELL DEFINED FUNDAMENTAL SOUND

Large **PMWB1-L** Medium **PMWB1-M**



ROUNDED PLAYING SURFACE

Medium **MWB1BK** Large **MWB2BK**

1 SYNTHETIC TEMPLE BLOCK SET

MATERIAL PE
FEATURES 5-piece set of durable synthetic percussion blocks; Varying pitch from high (smallest block) to low (largest block); Metal frame with adjustable thumb screw mount
INCLUDES Mounting Clamp; Beater
COLOR Black

2 PERCUSSION BLOCKS

MATERIAL PE
FEATURES Ultra-durable plastic
Mountable on three sides
MPE5: High pitched sound
MPE3: Medium pitched sound
MPE4: Low pitched sound
INCLUDES Mounting Clamp
COLORS **BK**: Black
NG: Neon Green
R: Red

3 WOOD TEMPLE BLOCK SET

MATERIAL Baltic Birch (*Betula pendula*)
FEATURES 5-piece tonally matched wood temple block set; 100% Baltic birch construction for natural wood tone; Rear mount fits any standard drum hardware; Tuning from low to high: D5, F5, A5, C6, D6
INCLUDES Two soft rubber head mallets

4 WOOD TEMPLE BLOCKS

MATERIAL Baltic Birch (*Betula pendula*)
TUNING **TMWB-XS**: D6
TMWB-S: C6
TMWB-L: F5
FEATURES Natural wood tone; Fits a variety of musical situations
INCLUDES Wood block holder

5 WOOD BLOCK HAND CLAP

MATERIAL Baltic Birch (*Betula pendula*)

FEATURES Combination wood block and hand clap effect; Padded surface to play with drumsticks

6 PROFESSIONAL WOOD BLOCKS

SIZES **M**: Medium
L: Large
MATERIALS Select Hardwood top
Siam Oak body
(*Hevea brasiliensis* Muell.-Arg.)
FEATURE Well defined fundamental sound
INCLUDES Wooden beater

7 WOOD BLOCKS

SIZES **MWB1BK**: Medium
MWB2BK: Large
MATERIAL Siam Oak (*Hevea brasiliensis* Muell.-Arg.)
FEATURE Rounded playing surface
INCLUDES Wooden beater
COLOR **BK**: Black, matte

LATIN INSTRUMENTS



8 PORTS FOR MORE VOLUME (PATENTED)

X-Small
PCA5BK-XS

Small
CA5BK-S

Medium
CA5BK

Large
CA5BK-L

9 ADJUSTABLE NET FOR VARIOUS TENSIONS AND SOUND OPTIONS

CA7BR

10

SH-R **SHR-BR** **SHK**

NEARLY UNBREAKABLE

11

RO3BK

12 TRUE SKIN BUFFALO HEADS

11"
MTA1SNT-M

13 HEAVY-DUTY STAND CAN BE TILTED

8" & 9"
HCG89NT

14

X-Small
MGU4

Small
MGU3

Large
MGU1

COMES WITH SCRAPER

15

MGU1

8" & 9"
HCG89NT

8 TURBO CABASAS (PATENTED)
SIZES **PCA5BK-XS**: X-Small; **CA5BK-S**: Small
CA5BK: Medium; **CA5BK-L**: Large
MATERIALS Steel chain and stainless steel cylinder
CA: Wooden handle with padded soft grip
PCA: Synthetic grip
FEATURE 5 sound ports on each side for more volume (CN, US patent)
COLOR **BK**: Black

9 CABASA, FIBERGLASS
MATERIAL Premium fiberglass
FEATURES Adjustable net for various tensions and sound options; Equals a traditional gourd calabash
COLOR **BR**: Brown

10 SHEKERES
SIZES **SH-R, SHR-BR**: Medium
SHK: Traditional

MATERIALS **SH-R, SHR-BR**: Premium fiberglass
SHK: Gourd
COLORS **BR**: Brown
R: Red

11 THE ROAR
MATERIAL Wood
FEATURE Rattling sustain

12 TAMBORA
SIZE 11"
MATERIALS Siam Oak (*Hevea brasiliensis* Muell.-Arg.)
True Skin Buffalo Heads
FEATURE Black powder coated hardware
INCLUDES Nylon strap; Wooden beaters; Tuning key
COLOR **SNT-M**: Super Natural
FINISH Matte

13 WOOD CONGUITAS
SIZES 8" & 9"

MATERIALS Siam Oak (*Hevea brasiliensis* Muell.-Arg.)
Hand selected buffalo heads
INCLUDES Height adjustable tilting double braced tripod stand; Tuning key; Wrench
COLOR **NT**: Natural
FINISH High gloss

14 MERENGUE GÜIRAS
SIZES **MGU4**: X-Small; **MGU3**: Small;
MGU1: Large
MATERIAL Brushed steel
FEATURE One-piece metal grip with welded flanges
INCLUDES ABS scraper MGS2

15 MERENGUE GÜIRA SHAKER
MATERIAL Brushed steel
FEATURE Filling inside to produce a cutting shaker effect
INCLUDES ABS scraper MGS2

LATIN INSTRUMENTS

CAJONS



The cajón is a versatile and dynamic percussion instrument rooted in Afro-Peruvian traditions and widely used across various musical genres. Its simple wooden box design delivers deep bass tones and sharp, snappy highs, making it perfect for both acoustic and amplified performances. Whether you're playing flamenco, Latin, or contemporary music, the cajón offers a rich rhythmic foundation. Ideal for drummers and percussionists alike, its portability and range of sounds make it an essential addition to any setup. Explore the rhythmic possibilities of the cajón and bring a new dimension to your music.



Mint Artisan Edition

HANDCRAFTED MASTERSHIP

MADE IN SPAIN

BY PEPOTE

ARTISAN EDITION CAJONS

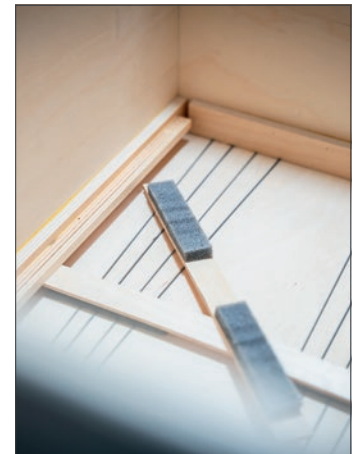
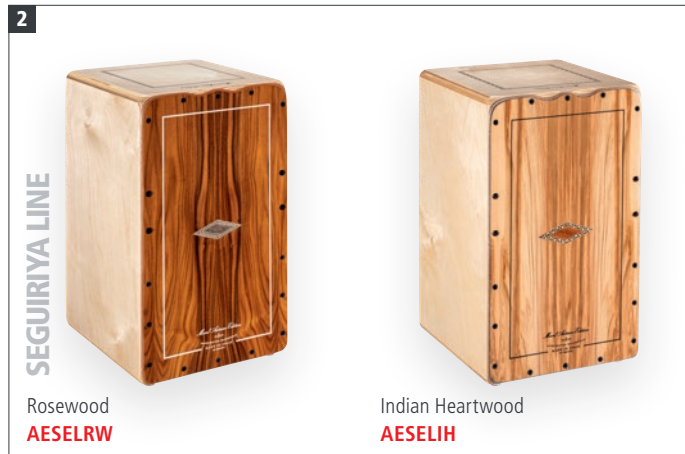

NEW ADJUSTABLE TENSION SYSTEM – INVENTED BY PEPOTE

All Artisan Edition Cajons now feature a newly developed Adjustable Tension System, designed by master cajon builder Pepote himself. This innovative mechanism allows players to fine-tune the side tension, enabling a clear separation between deep bass tones and crisp, sensitive snare sounds.

The system operates via internal adjustable braces, each equipped with high-quality foam padding that gently presses against the cajon's internal structure. This ensures a more controlled response, refined tonal definition, and an elevated level of customization for every playing style.

Depending on the line, the number of adjustable braces varies:

- Tano Line and Soleá Line: 2 adjustable internal bracings
- Bulería Line and Cantina Line: 3 adjustable internal bracings
- Seguriya Line and Martinete Line: 4 adjustable internal bracings

With this feature, players can achieve their perfect sound balance – from warm, resonant lows to articulate snare textures – making every Artisan Edition Cajon a truly professional and versatile instrument.



ARTISAN EDITION CAJONS

FEATURES Rounded corners and thumb notches for optimal playing comfort and sound
Ergonomically rounded frontplate with convex contact
Specially formulated soft rubber feet
Martinete, Seguriya, Cantina Line: Extra thick wooden sound port ring for compression
Two tuning screws to adjust the tension for each set of strings
Pop filter on soundhole
Seguriya, Cantina, Minera, Bulería, Soleá, Tango Line: Elegant heat-branding on resonating body

1 MARTINETE LINE

SIZE 11 1/2" W x 19" H x 12 3/4" D
MATERIALS Resonating body: Solid Wood (15 mm) Tulip Poplar (*Liriodendron tulipifera*)
Frontplate: Brazilian Ironwood (*Phoebe porosa*) with Ukola Woodframe
FEATURES Two sets of 10 adjustable strings (Separately per side)
6 specially formulated soft rubber feet
INCLUDES Tuning key

2 SEGURIYA LINE

SIZE 11 1/4" W x 19" H x 11 3/4" D
MATERIALS Resonating body: 9-Ply (12 mm) Baltic Birch (*Betula Pendula*)
AESELIH Frontplate: Indian Heartwood
AESELRW Frontplate: Rosewood
FEATURE Two sets of 8 adjustable strings (Separately per side)
INCLUDES Tuning key

3 CANTINA LINE

SIZE **AECLBE, AECLLI** 11 1/4" W x 19" H x 11 3/4" D
AECLWN 12 1/2" W x 18 1/2" H x 12 1/2" D
MATERIALS Resonating body: 9-Ply (12 mm) Baltic Birch (*Betula Pendula*)
AECLBE Frontplate: Brown Eucalyptus
AECLLI Frontplate: Limba
AECLWN Frontplate: Walnut
AECLBE, AECLLI
FEATURES Forward projecting sound port
Two sets of 6 pre-tuned strings
AECLWN
Two sets of 8 adjustable strings from the top (Separately per side)
Decorative wood inlay
INCLUDES Tuning key

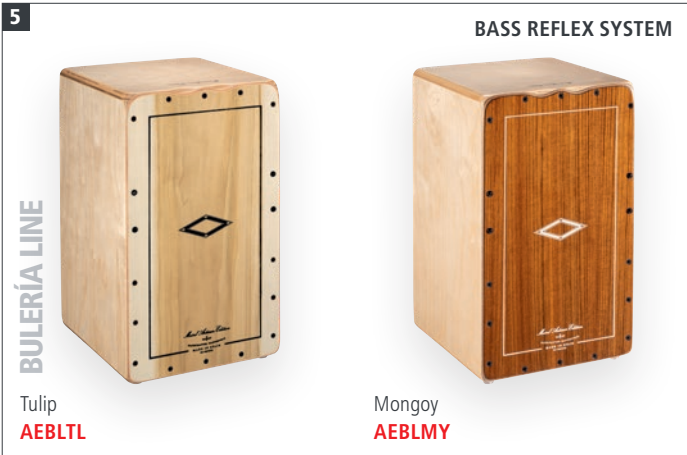

4 MINERA LINE
SIZE 11 1/4" W x 19" H x 11 3/4" D
MATERIALS Resonating body: 9-Ply (12 mm) Baltic Birch (*Betula Pendula*)
AEMILLI Frontplate: Limba
AEMILBE Frontplate: Brown Eucalyptus
FEATURE Two sets of 4 pre-tuned strings
INCLUDES Tuning key

5 BULERÍA LINE
SIZE 11 1/4" W x 19" H x 11 3/4" D
MATERIALS Resonating body: 9-Ply (12 mm) Baltic Birch (*Betula Pendula*)
AEBLMY Frontplate: Mongoy
AEBLTL Frontplate: Tulip

FEATURES Two sets of 5 adjustable strings (Separately per side)
 Tuning screw to adjust string tension
 Pop filter on soundhole
 Bass reflex system
INCLUDES Tuning key

6 SOLEÁ LINE
SIZE 11 1/4" W x 19" H x 11 3/4" D
MATERIALS Resonating body: 9-Ply (12 mm) Baltic Birch (*Betula Pendula*)
 Frontplate: Selected wood
FEATURES Two sets of 5 pre-tuned strings
 Bass reflex system
FINISHES **AESLEB** Frontplate: Espresso Burst
AESLEYB Frontplate: Ebony Burst
AESLRB Frontplate: Dark Red Burst

7 TANGO LINE
SIZE 11 1/4" W x 19" H x 11 3/4" D
MATERIALS Resonating body: 7-Ply (9 mm) Baltic Birch (*Betula Pendula*)
AETLBE Frontplate: Brown Eucalyptus
AETLBF Frontplate: Selected wood
AETLGE Frontplate: Grey Eucalyptus
AETLLE Frontplate: Light Eucalyptus
AETLLI Frontplate: Limba
AETLRF Frontplate: Selected wood
AETLSBK Frontplate: Selected wood
FEATURE Two sets of 3 pre-tuned strings
FINISHES **AETLBF** Frontplate: Blue Fade
AETLRF Frontplate: Red Fade
AETLSBK Frontplate: Satin Black

WOODCRAFT & HEADLINER® CAJONS



WOODCRAFT CAJONS **1** **2**

SIZE 11 3/4" W x 19 3/4" H x 12" D
FEATURES Custom micro-coiled steel cajon strings; Baltic birch construction; Rounded corners for added comfort; Rubber feet and rear sound port

1 WOODCRAFT PROFESSIONAL CAJONS

MATERIALS Resonating body: 9-Ply (12 mm) Baltic Birch (*Betula pendula*)
WCP100MB Frontplate: Makah-Burl
WCP100MH Frontplate: Mahogany

2 WOODCRAFT CAJONS

MATERIALS Resonating body: 7-Ply (9 mm) Baltic Birch (*Betula pendula*)
WC100B Frontplate: Baltic Birch (*Betula pendula*)
WC100EB Frontplate: Espresso Burst

3 HEADLINER® SERIES STRING CAJONS

SIZES **HCAJ1:** 11 3/4" W x 18" H x 12 1/4" D
HCAJ3: 11 3/4" W x 19 3/4" H x 12" D

MATERIALS **HCAJ1AWA, HCAJ3AWA**
 Resonating body: Eco-friendly medium density fiberboard
 Frontplate: Stained American White Ash (*Fraxinus Americana* L.)

HCAJ1NT
 Resonating body: Baltic Birch (*Betula pendula*)
 Frontplate: Baltic Birch (*Betula pendula*)

HCAJ3LJ
 Resonating body: Eco-friendly medium density fiberboard
 Frontplate: Baltic Birch (*Betula pendula*)

FEATURES Adjustable top corners; Adjustable sizzle effect; Internal fixed cajon strings; Wide sound options
HCAJ1: Anti-slip sitting surface

INCLUDES Hex key
FINISH **AWA, NT:** Matte
LJ: Lumberjack

4 HEADLINER® SERIES SNARE CAJONS

SIZE 11 3/4" W x 18" H x 11 3/4" D
MATERIALS Resonating body: Eco-friendly medium density fiberboard
MA Frontplate: Maple
CBF, LPF, PBF, SAF, TRF Frontplate: American White Ash (*Fraxinus Americana* L.)

FEATURES Dual internal fixed snare wires; Adjustable top corner; Wide sound options
FINISHES **CBF** Frontplate: Charcoal Black Fade
LPF Frontplate: Lilac Purple Fade
MA Frontplate: Natural
PBF Frontplate: Pacific Blue Fade
SAF Frontplate: Sonoran Amber Fade
TRF Frontplate: Tango Red Fade

SNARECRAFT CAJONS



5 FOOT ACTIVATED SNARE SWITCH SNARE SWITCH KNOB



American White Ash
SCP100AWA Walnut
SCP100WN

6



Almond Birch
SC80AB Almond Birch
SC100AB



Baltic Birch
SC80AB-B Baltic Birch
SC100AB-B



Baltic Birch
SC80B Baltic Birch
SC100B



Burl Wood
SC80BW Burl Wood
SC100BW



Heart Ash
SC80HA Heart Ash
SC100HA



Blue Burst
SC100BLB



Brown Burst
SC100BRB



Green Burst
SC100GRB



Red Burst
SC100RDB

5 SNARECRAFT PROFESSIONAL CAJONS

SIZE 11 3/4" W x 19 3/4" H x 12" D
MATERIALS Resonating body: 9-Ply (12 mm) Baltic Birch (*Betula pendula*)
SCP100AWA Frontplate: American White Ash (*Fraxinus Americana* L.)
SCP100WN Frontplate: Walnut
FEATURES Adjustable snare for both Flamenco and Peruvian styles; Baltic birch construction; Rounded corners for added comfort; Rubber feet and rear sound port
SCP100AWA Equipped with a foot activated snare switch
SCP100WN Equipped with a snare switch knob on the side of the cajon

6 SNARECRAFT CAJONS

SIZES **SC80:** 11 3/4" W x 18" H x 11 3/4" D
SC100: 11 3/4" W x 19 3/4" H x 11 3/4" D
MATERIALS **SC80AB, SC100AB** Resonating body: 7-Ply (9 mm) Baltic Birch (*Betula pendula*) Frontplate: Almond Birch (*Betula pendula*)
SC80AB-B, SC100AB-B Resonating body: 7-Ply (9 mm) Almond Birch (*Betula pendula*) Frontplate: Baltic Birch (*Betula pendula*)
SC80B, SC100B, SC100BLB, SC100BRB, SC100GRB, SC100RDB Resonating body: 7-Ply (9 mm) Baltic Birch (*Betula pendula*) Frontplate: Baltic Birch (*Betula pendula*)
SC80BW, SC100BW Resonating body: 7-Ply (9 mm) Baltic Birch (*Betula pendula*) Frontplate: Burl Wood

SC80HA, SC100HA

Resonating body: 7-Ply (9 mm) Baltic Birch (*Betula pendula*)
Frontplate: Heart Ash
FEATURES Dual internal fixed snare wires; Baltic birch construction; Rounded corners for added comfort; Rubber feet and rear sound port
FINISHES **BLB** Frontplate: Blue Burst
BRB Frontplate: Brown Burst
GRB Frontplate: Green Burst
RDB Frontplate: Red Burst

CAJONS



4 FORWARD FACING SOUND PORTS



1 JAM CAJONS

SIZE 10 1/2" W x 15" H x 10 1/4" D

MATERIALS **JC50AB** Resonating body: 7-Ply (9 mm) Baltic Birch (*Betula pendula*)
Frontplate: Almond Birch (*Betula pendula*)
JC50AB-B Resonating body: 7-Ply (9 mm) Almond Birch (*Betula pendula*)
Frontplate: Baltic Birch (*Betula pendula*)
JC50B Resonating body: 7-Ply (9 mm) Baltic Birch (*Betula pendula*)
Frontplate: Baltic Birch (*Betula pendula*)
JC50BW Resonating body: 7-Ply (9 mm) Baltic Birch (*Betula pendula*)
Frontplate: Burl Wood
JC50HA Resonating body: 7-Ply (9 mm) Baltic Birch (*Betula pendula*)
Frontplate: Heart Ash

FEATURES Compact size; Baltic birch construction; Dual internal fixed snare wires; Rubber feet and rear sound port

2 SLAPTOP CAJONS (PATENTED)

SIZES **TOPCAJ1MB** 14 1/2" W x 8 3/4" H x 5 3/4" D
TOPCAJ2WN (Turbo Slaptop) 14 1/2" W x 10" H x 5 3/4" D

MATERIALS **TOPCAJ1MB** Resonating body: Eco-friendly medium density fiberboard; Playing surface: Makah-Burl
TOPCAJ2WN (Turbo Slaptop) Resonating body: Eco-friendly medium density fiberboard; Playing surface: Walnut (*Juglans regia* L.)

FEATURES Comfortable upright playing style; Forward facing sound ports; Dual internal fixed snare wires; Deep bass and cutting slap tones
TOPCAJ2WN (Turbo Slaptop) Snares on both sides

3 HYBRID SLAPTOP CAJON

SIZE 14 1/2" W x 10" H x 5 3/4" D

MATERIAL Baltic Birch (*Betula pendula*)

FEATURES Comfortable and unique X-design; Forward sound projection; Dual internal fixed snare wires for a snare cajon sound on one side; Bongo cajon sound on the opposite side

4 TRAVEL SLAPTOP CAJON

SIZE 18 3/4" W x 2 3/4" H x 9 1/2" D

MATERIALS Resonating body: Eco-friendly medium density fiberboard; Playing surface: Maple

FEATURES Comfortable upright playing style; Forward facing sound ports; Dual internal fixed snare wires; Crisp snare cajon sound

6 INTERNAL SNARE WIRES



Natural/Ebony Black, matte
BCA2NT/EBK-M

DIFFERENT SIZED CHAMBERS ENABLE AN AUTHENTIC BONGO EFFECT



Super Natural, matte
BCA1SNT-M

7 TWO SOUND OPTIONS



TMBX

8



Makah-Burl, matte
SUBCAJ6MB-M

VERTICAL FORWARD FACING SOUND PORTS



9



Walnut, matte
SUBCAJ5WN

JUMBO BASS SUBWOOFER CAJON



American White Ash, matte
SUBCAJ1AWA

SUPER LOW FREQUENCY

5 TRAVEL CAJON
 SIZE 11 3/4"
 MATERIAL Siam Oak (*Hevea brasiliensis* Muell.-Arg.)
 FEATURES Internal snare wires; Compact design

6 BONGO CAJONS
 SIZE 15 3/4" W x 6 3/4" H x 7 1/4" D
 MATERIAL Siam Oak (*Hevea brasiliensis* Muell.-Arg.)
 FEATURES High and low pitch playing surface; Compact size and light weight
BCA2: Dual internal fixed snare wires

7 BOXITO
 SIZE 11" W x 8 1/2" H x 5 3/4" D
 MATERIALS Resonating body: Baltic Birch (*Betula pendula*); Playing surface: Baltic Birch (*Betula pendula*), Exotic Zebrano
 FEATURES Dual playing surfaces bongo/snare; Internal fixed snare wires; Natural wood tone

8 VERTICAL SUBWOOFER CAJON
 SIZE 15 1/2" W x 19 1/4" H x 11 3/4" D
 MATERIALS Resonating body: Eco-friendly medium density fiberboard; Frontplate: Makah-Burl
 FEATURE Dual internal fixed snare wires and bass reflex channel

9 SUBWOOFER CAJONS
 SIZES **SUBCAJ1AWA** 11 3/4" W x 19 3/4" H x 12 1/4" D
SUBCAJ5WN 13 1/2" W x 19 3/4" H x 13 3/4" D
 MATERIALS Resonating body: Eco-friendly medium density fiberboard
SUBCAJ1AWA Frontplate: American White Ash (*Fraxinus Americana* L.)
SUBCAJ5WN Frontplate: Walnut (*Juglans regia* L.)
 FEATURES Forward projecting sound port; Dual internal fixed snare wires

PICKUP CAJONS

1 **PIEZO PICKUP WITH VOLUME AND TONE CONTROL**



SOLEÁ LINE

Dark Olive Burst
PAESLDOB

2



Baltic Birch
PWC100B

Makah-Burl
PWCP100MB

3



Baltic Birch
PSC100NT

Baltic Birch
PSC100B

4



Baltic Birch
PJC50B

5



Baltic Birch
PSUBCAJ6B

6 **INDIVIDUAL SNARE AND BASS CONTROL**



Walnut
PTOPCAJ2WN

Mahogany
PTOPCAJ4MH-M

1 ARTISAN EDITION PICKUP CAJON, SOLEÁ LINE

SIZE 11 1/4" W x 19" H x 11 3/4" D
MATERIALS Resonating body: 9-Ply (12 mm) Baltic Birch (*Betula Pendula*)
 Frontplate: Dark Olive Burst
FEATURES Piezo pickup with volume and tone control; Two sets of 5 pre-tuned strings; Rounded corners and thumb notches for optimal playing comfort and sound; Ergonomically rounded frontplate with convex contact; Bass reflex system

2 PICKUP WOODCRAFT SERIES CAJONS

SIZES **PWC100B** (Woodcraft) 11 3/4" W x 19 3/4" H x 12" D
PWCP100MB (Woodcraft Professional) 11 3/4" W x 19 3/4" H x 12" D
MATERIALS Resonating body: Baltic Birch (*Betula pendula*)

FEATURES Three Piezo pickups for snare and bass sounds; Rubber feet and rear sound port
COLORS **PWC100B** Resonating body: Natural
PWCP100MB Resonating body: Black

3 PICKUP SNARECRAFT SERIES CAJONS

SIZE 11 3/4" W x 19 3/4" H x 11 3/4" D
MATERIALS Resonating body: Baltic Birch (*Betula pendula*)
 Frontplate: Baltic Birch (*Betula pendula*)
FEATURES Three Piezo pickups for snare and bass sounds; Baltic birch construction
COLORS **PSC100B** Resonating body: Black

PSC100NT
 Resonating body: Natural

4 PICKUP JAM CAJON

SIZE 10 1/2" W x 15" H x 10" D
MATERIALS Resonating body: Baltic Birch (*Betula pendula*)
 Frontplate: Baltic Birch (*Betula pendula*)
FEATURES Compact size; Dual internal fixed snare wires; Piezo pickup with volume control
COLOR Natural

5 PICKUP VERTICAL SUBWOOFER CAJON

SIZE 15 1/2" W x 19 1/4" H x 11 3/4" D
MATERIALS Resonating body: Eco-friendly medium density fiberboard
 Frontplate: Baltic Birch (*Betula pendula*)
FEATURES Vertical forward-facing sound ports; Piezo pickup with volume and tone control; Dual internal fixed snare wires



7



Birch Wood
MPDC1

DIGITAL CAJON FOR EXPANDED SOUND OPTIONS AND SILENT PRACTICE

DIGITAL CAJON SOUNDS

- 0 - MEINL Subwoofer Cajon + MEINL Tambourine
- 1 - MEINL Snarecraft Cajon + MEINL Splash Cymbal
- 2 - MEINL Cantina Line Artisan Cajon + MEINL Closed Hihat Cymbal
- 3 - MEINL Slaptop Cajon + Hand Clap
- 4 - MEINL Woodcraft Cajon + MEINL Crash Cymbal
- 5 - Rock Drum Kit + MEINL Closed Hihat Cymbal
- 6 - Drum Machine + MEINL Ride Cymbal
- 7 - MEINL Marathon® Classic Congas
- 8 - MEINL Fibercraft Bongos + MEINL Percussion Block
- 9 - MEINL Diego Galé Signature Timbales + MEINL Steel Craft Cowbell

9



Baltic Birch
MMCS



CAJON MICROPHONE STAND (SEE PAGE 120)
CMS

8

TWO 4.5" 20-WATT SPEAKERS



Baltic Birch
MPSCAJ

PRACTICE TO MUSIC OR INCORPORATE LOOPS IN YOUR PERFORMANCES

10



MIC-PERC

11



PA-CAJ

MICROPHONE CAJON CLAMP
(SEE PAGE 127)



MPMCC

6 PICKUP SLAPTOP CAJONS (PATENTED)

SIZES **PTOPCAJ2WN** (Turbo Slaptop)
14 1/2" W x 10" H x 5 3/4" D
PTOPCAJ4MH-M
15 1/2" W x 8 1/2" H x 7 1/2" D

MATERIALS **PTOPCAJ2WN** (Turbo Slaptop)
Resonating body: Baltic Birch (*Betula pendula*)
Playing surface: Walnut (*Juglans regia* L.)
PTOPCAJ4MH-M
Resonating body: Eco-friendly medium density fiberboard
Playing surface: Mahogany

FEATURES Passive pickup system with high quality output jack; Individual snare, bass, and tone control; Playing surface with dual internal fixed snare wires; Forward facing sound ports
PTOPCAJ2WN (Turbo Slaptop)
Snares on both sides

7 DIGITAL CAJON

SIZE 12" W x 20" H x 12" D

MATERIALS Resonating body: Birch Wood
Playing surface: Open cell acoustic foam

FEATURES Four rubber trigger pads in a natural cajon playing position; Ten pre-programmed digital sounds

INCLUDES Power supply; Foot switch

COLOR Black

8 SPEAKER CAJON

SIZE 11 3/4" W x 19 3/4" H x 11 3/4" D

MATERIALS Resonating body: Baltic Birch (*Betula pendula*)
Frontplate: Baltic Birch (*Betula pendula*)

FEATURES Practice to music or incorporate loops in your performances; Supports wireless connection with your phone

INCLUDES Micro SD card

COLOR Resonating body: Black

9 MINI CAJON SPEAKER

SIZE 5 3/4" W x 8 3/4" H x 5 3/4" D

MATERIALS Resonating body: 5-Ply (6 mm) Baltic Birch (*Betula pendula*)
Frontplate: Baltic Birch (*Betula pendula*)

FEATURES Listen to your favorite music or podcast; Supports wireless, USB and auxiliary connection; Great gift idea for percussionists

10 PERCUSSION MICROPHONE

FEATURES Low-profile condenser microphone with adhesive backing; Great for cajons, congas, djembes or frame drums

INCLUDES Eighth-inch cable to quarter-inch adapter

11 CAJON PREAMP

FEATURES Robust Cajon Pickup/Preamp; Wide range tone control; High-quality signal output; Fits most cajons

MINI & MAKE YOUR OWN CAJONS

1

MINIATURE SIZE OF A CAJON WITH INTERNAL FIXED SNARE WIRES



Almond Birch
MC1AB

Baltic Birch
MC1AB-B

Baltic Birch
MC1B

Burl Wood
MC1BW

Heart Ash
MC1HA



2

ALL NEEDED TOOLS INCLUDED



Burl Wood
DMYO-CAJ-BU

DELUXE MODEL
FEATURES LARGER SIZE

3



Baltic Birch
MYO-CAJ

4

POPS UP FROM A FLAT PIECE INTO A FULL SIZE CAJON



Cajon2Go
VR-CAJ2GO

5



Baltic Birch
MYO-BCAJ

3



Ovangkol
MYO-CAJ-OV

ASSEMBLY INSTRUCTION COMES
IN DIFFERENT LANGUAGES

6



MYO-TOOLS

<p>1 MINI CAJONS</p> <p>SIZE 5 3/4" W x 8 3/4" H x 5 3/4" D</p> <p>MATERIALS MC1AB Resonating body: 5-Ply (6 mm) Baltic Birch (<i>Betula pendula</i>) Frontplate: Almond Birch (<i>Betula pendula</i>)</p> <p>MC1AB-B Resonating body: 5-Ply (6 mm) Almond Birch (<i>Betula pendula</i>) Frontplate: Baltic Birch (<i>Betula pendula</i>)</p> <p>MC1B Resonating body: 5-Ply (6 mm) Baltic Birch (<i>Betula pendula</i>) Frontplate: Baltic Birch (<i>Betula pendula</i>)</p> <p>MC1BW Resonating body: 5-Ply (6 mm) Baltic Birch (<i>Betula pendula</i>) Frontplate: Burl Wood</p>	<p>MC1HA Resonating body: 5-Ply (6 mm) Baltic Birch (<i>Betula pendula</i>) Frontplate: Heart Ash</p> <p>FEATURES Internal fixed snare wires; Miniature size; Birch construction; Great gift idea</p> <p>MAKE YOUR OWN 2 3 4</p> <p>CONTAINS All of the materials and assembly instructions for completing the cajon</p> <p>2 DELUXE MAKE YOUR OWN CAJON</p> <p>SIZE 12" W x 19 1/4" H x 12" D</p> <p>MATERIALS Resonating body: Baltic Birch (<i>Betula pendula</i>) Frontplate: Burl Wood</p> <p>INCLUDES All of the tools for completing the cajon</p>	<p>3 MAKE YOUR OWN CAJONS</p> <p>SIZE 11 3/4" W x 18" H x 11 3/4" D</p> <p>MATERIALS Resonating body: Baltic Birch (<i>Betula pendula</i>) MYO-CAJ Frontplate: Baltic Birch (<i>Betula pendula</i>) MYO-CAJ-OV Frontplate: Ovangkol (<i>Guibourtia ehie</i>) Steel snare wires</p> <p>COLOR Natural</p> <p>4 CAJON2GO</p> <p>SIZE 13 1/2" W x 18" H x 12 1/2" D</p> <p>MATERIAL Cardboard</p> <p>FEATURES Folds from a single flat piece into a full size cajon; Internal fixed set of snare wires; Comfortably holds up to 150 kg / 330 lbs; Naturally deep bass and crisp snare sounds</p>
--	--	--

CAJON PEDALS



7

SPECIALLY POSITIONED CURVED STEEL BAR WITH DIRECT DRIVE



TMSTCP

8

CAN BE PLAYED WITH YOUR HEEL OR TOES

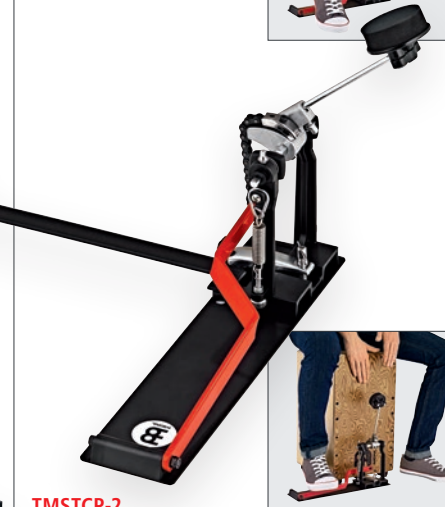

TMSTCP-2

9



TMCP-2

BASSBOX / SNAREBOX PEDAL
(SEE PAGE 63)



TMBP

10

FOR PRONOUNCED KICK SOUND



Foam rubber
CPB1

11

ADJUSTABLE BRASS JINGLES



Soft foam
CPB2

12

DELIVERS HEAVY, FULL STROKES



Polymer bristles
CPB3

13

FOR DEEP AND PUNCHY NOTES



Soft foam
CPB4

14

GREAT FOR LOW VOLUME SETTINGS



Artificial fur
CPB5

5 MAKE YOUR OWN BONGO CAJON

SIZE 15 3/4" W x 6 3/4" H x 7 1/4" D
MATERIAL Baltic Birch (*Betula pendula*)
COLOR Natural

6 MAKE YOUR OWN CAJON TOOL BOX

CONTAINS 1 x screwdriver; 1 x wood glue; 2 x tension straps; 2 x sanding pads (coarse and fine)
FEATURE One-stop shop for all necessary tools to complete the Meinl Make Your Own Cajons and Bongo Cajon

7 DIRECT DRIVE CAJON PEDAL

MATERIAL Steel
FEATURES Cradle-like mount fits all common cajons; Adjustable spring tension; Natural foot position for ease of use

8 DIRECT DRIVE HEEL ACTIVATED CAJON PEDAL

MATERIAL Steel
FEATURES Simple design for steady bass drum rhythms; Cradle-like mount fits most cajons

9 PROFESSIONAL CAJON PEDAL

MATERIAL Steel
FEATURES Position anywhere for optimal playability; For right and left-footed players

10 HAMMER HEAD CAJON & BASS DRUM BEATER

MATERIAL Foam rubber
FEATURES Soft foam rubber draws a deep bass sound from cajons; Dual playing surfaces for a variety of boom and punch

11 JINGLE CONTACT CAJON & BASS DRUM BEATER

MATERIALS Soft foam rubber; Brass jingles
FEATURE Easily turn the jingles on or off as desired throughout your set

12 BRUSH CAJON & BASS DRUM BEATER

MATERIAL Rippled polymer bristles
FEATURES Extra thick set of wavy polymer bristles; Two adjustable control rings; Warm, slightly mellow attack

13 STANDARD CAJON & BASS DRUM BEATER

MATERIAL Soft foam rubber

14 WOOLLY MAMMOTH CAJON BEATER

MATERIALS Artificial fur; Soft foam

CAJON DRUM SETS

1



MORE INFO

MAY BE EASILY ARRANGED FOR RIGHT OR LEFT HANDED PLAYERS

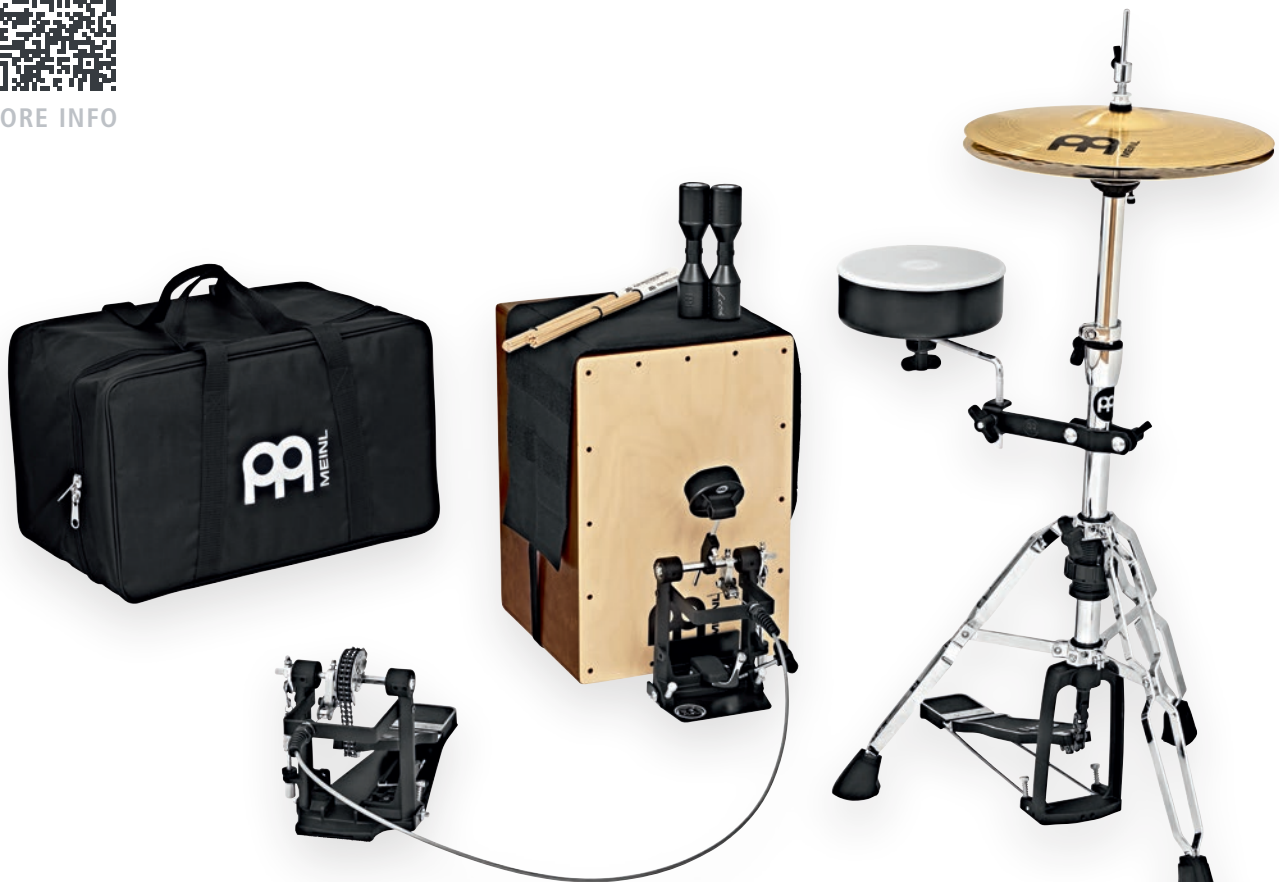

Set
CAJ-DRUMSET

PORTABLE RHYTHM STATION



2



MDTK

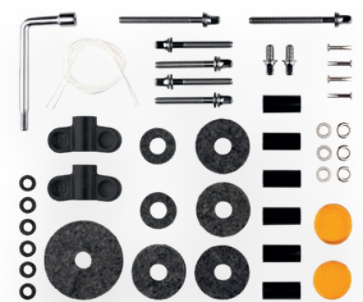

1 CAJON DRUM SET

CONTAINS Birch wood cajon without snares for enhanced bass
Cajon Pedal
Mountable Cajon Snare including silicone protection cover
Multi-Clamp
HCS 13" hi-hat cymbal pair with Low Hat
Bamboo Flex Multi-Rods for Cajon
Cajon Blanket with pockets for accessories
Luis Conte Live Shaker
Cajon Gig Bag

FEATURES

May be easily arranged for right or left handed players
This set includes everything needed for players looking to perform their normal drum set rhythms in smaller, intimate acoustic settings
The elements of this set give you the same feeling as sitting down at a drum kit

2 DRUM TECH KIT

CONTAINS 1 x L-Shaped Drum Key
4 x Drum Honey Gel Pads
6 x Synthetic Cymbal Sleeves
4 x Steel Cymbal Rivets
4 x Cymbal Felts
2 x Hi-hat Clutch Felts
1 x Hi-hat Base Felt
2 x 8 mm Wing Nuts
6 x Metal Washers
6 x Synthetic Washers
2 x Nylon Snare Cords
2 x Short Tension Rods
4 x Medium Tension Rods
2 x Long Tension Rods

FEATURES

Includes 14 of the most common and important tools for drummers and techs; For gig emergencies, routine maintenance, restoration or replacing lost parts

INCLUDES

Storage container for organization

3

CONVERTS ANY STANDARD CAJON INTO A BASS DRUM



MORE INFO



Set
CAJ-KIT

4

CUTTING SNARE SOUND



MCS1-BK



5

SHIELDS YOUR SNARE CAJON FROM STICK MARKS OR SCRATCHES



SCOVER



3 CAJON DRUM SET CONVERSION KIT

- CONTAINS** Direct Drive Cajon Pedal
Mountable Cajon Snare including silicone protection cover
Multi-Clamp
HCS 13" hihat cymbal pair with Low Hat
Bamboo Flex Multi-Rods for Cajon
Cajon Blanket with pockets for accessories
Luis Conte Live Shaker
Cajon Gig Bag
- FEATURES** Converts any standard cajon into a bass drum (cajon not included)
Expand your cajon into a small, reduced volume drum set
Low-key stage footprint
Perfect for acoustic shows, jam sessions, or street performances

4 MOUNTABLE CAJON SNARE

- SIZE** 7 1/2"
- MATERIAL** Siam Oak (*Hevea brasiliensis* Muell.-Arg.)
- FEATURES** Internal Snare Wires
Standard 3/8" rod mounting bracket
- INCLUDES** L-shaped rod with knurled surface
- COLOR** **BK**: Black

5 SILICONE PROTECTION COVER

- SIZE** 7 1/2"
- MATERIAL** Silicone
- FEATURES** Shields your snare cajon from stick marks or scratches
Removable at any time

CAJON DRUM SETS



1 COCKTAIL CAJON KIT

CONTAINS Cocktail Cajon; Tom Tap; Snare Tap; Bongo Cajon Tap; Husk Brush (SB307); Foot Pedal (TMBP); Pedal Beater (CPB4); 3 x L-shaped rod (MC-R5); Splitter

2 KICK DRUM CAJON

SIZE 11 3/4" W x 19 3/4" H x 11 3/4" D
MATERIALS Resonating body: 7-Ply (9 mm) Baltic Birch (*Betula pendula*)
Frontplate: Baltic Birch (*Betula pendula*)
FEATURES Multiple attachments to build an acoustic drum setup; Full size cajon without snares or strings for pure bass tone
INCLUDES Cymbal arm; Z-shape rod (plus mounts); pedal attachment plate; cajon beater

3 COMPACT PERCUSSION PAD

SIZE 6 1/2"
MATERIAL ABS

FEATURES 5 pre-programmed sounds; Ideal for multi-instrumentalists and percussionists; Sensitive rubber surface for responsive hand and stick notes

INCLUDES Rechargeable battery and USB-C cable 9000, SDS & 808 Snare, Tambourine, Hand Clap

4 THE ULTIMATE PERCUSSION SAMPLE BOX

MATERIAL Aluminum
FEATURES Converts the input signal into percussion sound effects; Can use any analog stomp box or electronic trigger pad as signal generator; Controller for volume, sound selection, touch response; High-quality 1/4" TRS input and output jack; 3/8" eye bolt mount; Rechargeable battery and USB-C included (cable not included); Built-in OLED screen

5 MERGER

MATERIAL Aluminum
FEATURES Combine multiple percussion audio signals into one output; Contains 6 inputs, 1 XLR output and 1 AUX input

6 INSTRUMENT CABLES

SIZES **MPIC-5:** 5 ft / 1.5 m
MPIC-10: 10 ft / 3 m
MPIC-15: 15 ft / 4.5 m
MPIC-20: 20 ft / 6 m
MPIC-30: 30 ft / 9 m
FEATURES 8 mm diameter with high-quality 1/4" straight connectors; Wire gauge: 24 AWG

7 COCKTAIL CAJON INSTRUMENT CABLE SET

CONTAINS 4 x 5 ft Instrument Cable (MPIC-5)
1 x 30 ft Instrument Cable (MPIC-30)
FEATURE 5-piece Meinl Percussion Instrument Cable set for the Meinl Cocktail Cajon Kit

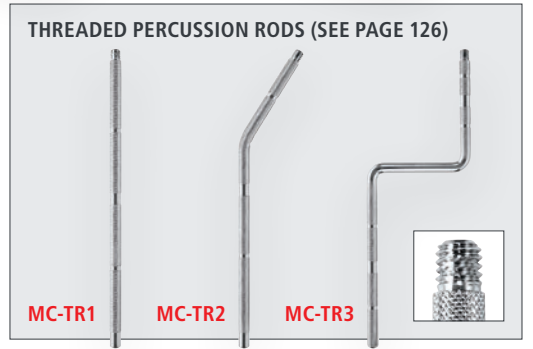
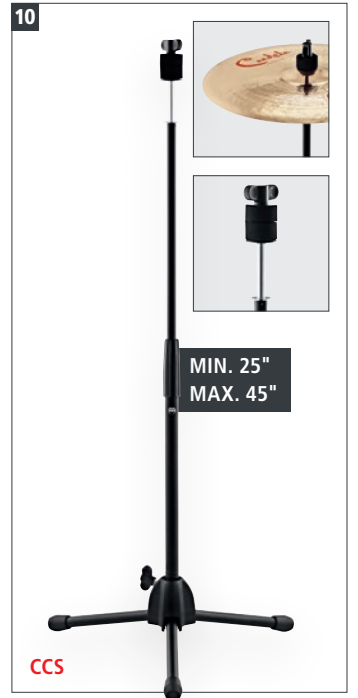
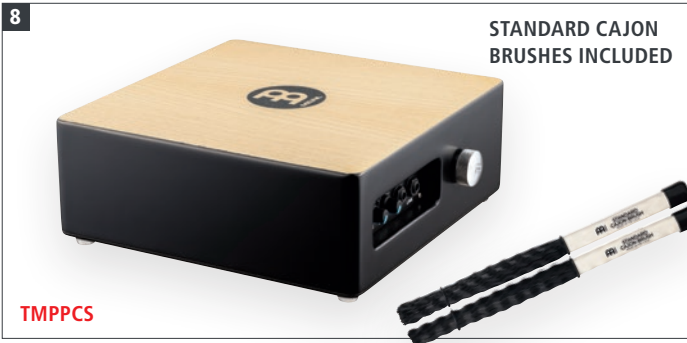

8 PROFESSIONAL PICKUP CAJON SNARE
 SIZE 13" W x 6" H x 13" D
 MATERIALS Resonating body: MDF
 Playing surface: American White Ash (*Fraxinus Americana* L.)
 INCLUDES Standard Cajon Brushes (SB305)

CAJON DRUM SET STANDS 9 10 11
 MATERIAL Black powder coated steel
 FEATURE Foldable legs, height adjustable

9 CAJON HIHAT STAND
 FEATURES Standard hihat clutch and padded seat;
 Fixed internal rod for closed hihat sound

10 CAJON CYMBAL STAND
 FEATURES Standard cymbal stand top;
 Use with any cymbal type

11 CAJON ADD-ON STAND
 FEATURE 3/8" threaded connector top

CAJON TAPS 12 13 14
 SIZE 5 3/4"
 MATERIAL Siam Oak (*Hevea brasiliensis* Muell.-Arg.)
 FEATURE Threaded 3/8" connection underneath
 FINISH Black

12 CAJON JINGLE TAP
 FEATURE Stainless steel jingles for bright accents

13 CAJON SNARE TAP
 FEATURE Internal snares for high pitched snare cajon sound

14 CAJON TOM TAP
 FEATURE Hollow inside for a high pitched "tom" sound

15 MOUNTABLE CAJON SNARE WITH THREADED 3/8" CONNECTION
 SIZE 7 1/2"
 MATERIAL Siam Oak (*Hevea brasiliensis* Muell.-Arg.)
 INCLUDES Silicone Protection Cover
 COLOR BK: Black

CAJON ADD-ONS



1 CAJON SIDE MOUNT

MATERIAL Siam Oak (*Hevea brasiliensis* Muell.-Arg.)
FEATURES Easy handling; Hook and loop fastener goes on any surface; Offers better cajon accessory placement
COLOR Black

2 CAJON CASTANET

MATERIAL Siam Oak (*Hevea brasiliensis* Muell.-Arg.)
FEATURES Spring-opened; Hook and loop fastener goes on any surface
COLOR Black
FINISH Matte

3 CAJON JINGLE CASTANET

MATERIAL Siam Oak (*Hevea brasiliensis* Muell.-Arg.)
FEATURES Spring-opened; Hook and loop fastener goes on any surface; Stainless steel jingles
COLOR Black
FINISH Matte

4 JINGLE TAP

MATERIAL Siam Oak (*Hevea brasiliensis* Muell.-Arg.)
FEATURES Stainless steel jingles; Hook and loop fastener goes on any surface
COLOR **BK:** Black

5 WOOD SIDE SNARE

MATERIAL Siam Oak (*Hevea brasiliensis* Muell.-Arg.)
FEATURES Internal snare effect; Hook and loop fastener attaches to Cajon body; Ergonomic shape; Unobtrusive low profile
COLOR **BK:** Black
FINISH Matte

6 CAJON TURBO CABASAS

SIZES **CCAB-S:** Small
CCAB: Medium (traditional size)
MATERIALS Steel chain and stainless steel cylinder
FEATURES Add cabasa or loose hihat effects to cajon grooves; Five sound ports for extra projection

7 CAJON BLANKET

MATERIAL Heavy-duty nylon
FEATURES Fits on any cajon; Hook and loop fastener to mount additional add-ons
COLOR Black

8 CAJON KINETIC TUNING KEY

MATERIAL Molded ABS
FEATURES Adjust cajon string tension and cajon frontplate screws; Dual crosshead screw-driver and hex key; Wide wing Meinl logo designed for a firm grip



9 KNEE PAD JINGLE TAP & KNEE PAD SNARE TAP

MATERIAL Siam Oak (*Hevea brasiliensis* Muell.-Arg.)
FEATURES Strap with hook and loop fastener to mount on your leg
KP-JT-BK: Stainless steel jingles
KP-ST-BK: Snare effect
COLOR **BK:** Black

10 MOTION SHAKER

MATERIAL Synthetic
FEATURES Comfortable to wear on your fingers; Cutting shaker sound
COLOR **BK:** Black

11 CAJON RING CASTANETS

MATERIALS **CRC1BK:** Siam Oak (*Hevea brasiliensis* Muell.-Arg.)
PCRC1BK: Synthetic
COLOR **BK:** Black

12 FINGER JINGLES

MATERIALS Siam Oak (*Hevea brasiliensis* Muell.-Arg.)
FJS1A: Aluminum jingles
FJS1S: Stainless steel jingles

13 CAJON PEDAL MOUNT

MATERIAL Baltic Birch (*Betula pendula*)
FEATURES Play your cajon just like a kick drum; Accommodates any size cajon; Fits all bass drum pedals; Adjustable wooden plate secures your cajon

14 SYNTHETIC LEATHER CAJON SEATS

MATERIAL Sleek faux leather
FINISHES **GR:** Grey
VBR: Vintage Brown

15 DELUXE CAJON SEATS

SIZE 9 3/4" x 9 1/2"
MATERIALS Inner material foam
 Outer material leatherette
FEATURES Provides comfort while sitting on your cajon; Filled with extra-thick padding; Elegant cross-stitching for high-end look and durability; Special underside surface grips any cajon (no adhesives necessary)
COLORS **DCS:** Black
DCS-R: Bordeaux

16 CAJON PAD

SIZE 10" x 10"
MATERIAL Soft foam

17 CAJON PERC PACK

CONTAINS Cajon Pad; Compact Foot Tambourine; Motion Shaker; Cajon Castanet, large; Luis Conte Live Shaker

STOMP BOXES & EFFECTS PEDALS

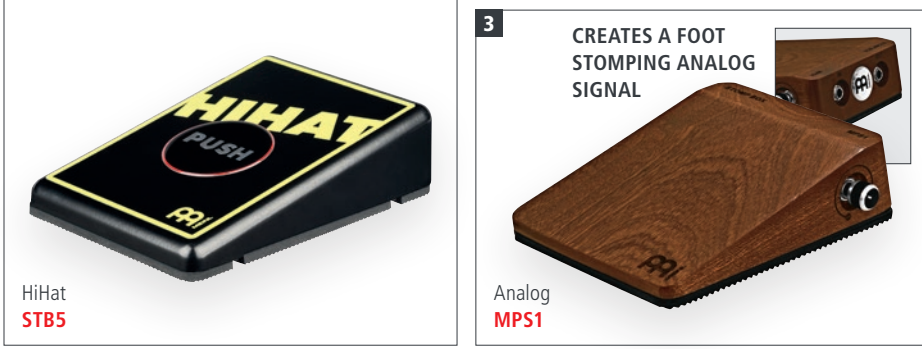
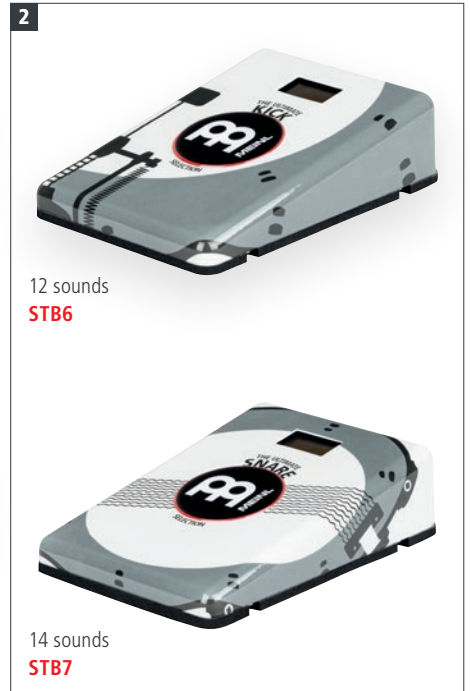

1 PERCUSSION STOMP BOXES
MATERIAL Aluminum
FEATURES Create hands-free beats by tapping your foot; Pre-programmed percussion sound effect; Perfect for cajon players, guitarists and multi-instrumentalists; High-quality 1/4" output jack
SOUNDS **STB1:** Kick
STB2: Cowbell
STB3: Clap
STB4: Tambourine
STB5: HiHat

2 THE ULTIMATE STOMP BOXES
MATERIAL Aluminum
FEATURES Create hands-free beats by tapping your foot; Perfect for cajon players, guitarists or multi-instrumentalists; High-quality 1/4" TRS input and output jack; Runs with 2 x AA 1.5V batteries (not included)

3 PERCUSSION STOMP BOX, ANALOG
MATERIAL Solid Mahogany body
FEATURES Perfect for percussionists and multi-instrumentalists; 1/4" input and output jacks; Creates a foot stomping analog signal; Built-in Piezo pickups with volume control

4 EFFECTS PEDALS
MATERIALS ABS; Steel
FEATURES Ideal for multi-instrumentalists and percussionists
FX5: 5 pre-programmed sounds; Hands-free beats
FX20: Ten pre-programmed percussion samples and ten custom samples; Weighted body for a sturdy feel; Highly dynamic pedal with smooth spring back an no sound interference
INCLUDES **FX5:** Rechargeable battery, USB-C cable
FX20: Micro SD card and power supply with international adapters
SOUNDS **FX5:** Pop; Doom; SDS; 808 Sub; Soft Kick
FX20: Kick Bass; Soft Kick; 808 Bass; 808 Snare; HiHat; Clave; Hand Clap; Cowbell; Straight Tambourine; Shaker

SOUNDS **STB6:** Kick Bass; Pop Kick; Soft Kick; 808 Bass; 909 Bass; SDS Bass; Cannon Kick; Doom Kick; Bass 'n' Ride; Oriental; Doumbek Bass; 808 Subkick
STB7: Soul Snare; 9000 Snare; 909 Snare; 808 Snare; Brass Snare; SDS Snare; Pop Snare; Doumbek Slap; HipHop Snare; Reggae Snare; Snare + Clap; Snare + Tambourine; Brush Snare; Sidestick
STB8: Tambourine; Cowbell; Clap; Shaker; Pedal Hihat; Woodblock; Bongo; Conga; Darbuka; Timbale; Djembe; Slight Bell; Maracas; Claves; Guiro; Crasher

INCLUDES L-shaped soft foam beater

BASSBOXES & SNAREBOXES



FOOT PERCUSSION

6 ALUMINUM RAIL TO MOUNT ANY COMMON FOOT PEDAL

Bassbox
BASSBOX

IMMENSE BASS SOUND

Pickup Bassbox
PBASSBOX

L-SHAPED SOFT FOAM BEATER INCLUDED

7 TWO INTERNAL SNARE WIRES

Snarebox
SNAREBOX

CRISP SNARE SOUND

Pickup Snarebox
PSNAREBOX

L-SHAPED FELT BEATER INCLUDED

8

Soft foam
BBB2

9

Felt
SBB1

10

Brass jingles
BBB1

11

Foam rubber
BBB3

12

Artificial fur
BBB4



13

PERFECT FOR THE MEINL BASSBOX AND SNAREBOX

TMBP



5 TRIGGER PEDAL
MATERIAL ABS; Steel
FEATURES Pedal activated trigger; Transmits sounds from your sound module; Hands-free use

6 BASSBOX & PICKUP BASSBOX
SIZE 17 1/2" W x 6 3/4" H x 11 3/4" D
MATERIAL Resonating body: Baltic Birch (*Betula pendula*)
FEATURES Perfect for guitarists and singers; Immense bass sound
PBASSBOX: Piezo pickup with high quality output jack
INCLUDES L-shaped soft foam beater
COLOR Black
FINISH Matte

FEATURES Perfect for guitarists and singers
PSNAREBOX: Piezo pickup with high quality output jack
INCLUDES L-shaped felt beater
COLOR Black
FINISH Matte

8 BASSBOX BEATER
MATERIAL Soft foam rubber
FEATURE Punchy response

9 SNAREBOX BEATER
MATERIAL Felt
FEATURE Crisp snare response

10 JINGLE CONTACT BASSBOX/SNAREBOX BEATER
MATERIALS Soft foam rubber; Brass jingles
FEATURE Soft L-shaped foam rubber beater with adjustable brass jingles

11 HAMMER HEAD BASSBOX/SNAREBOX BEATER
MATERIAL Foam rubber
FEATURES Hammer Head shape for a pronounced kick sound; Dual playing surfaces for boom or punch; Draws out a naturally deep tone

12 WOOLLY MAMMOTH BASSBOX/SNAREBOX BEATER
MATERIALS Artificial fur; Soft foam
FEATURES Woolly Mammoth beater produces a soft kick sound; Delivers a mellow attack for low volume and texture

13 BASSBOX/SNAREBOX PEDAL
MATERIAL Steel
FEATURE Adjustable spring tension to dial in your comfort zone

FOOT PERCUSSION



Stainless steel jingles
FJS2S-BK



Stainless steel jingles
CFJS2S-BK



Stainless steel jingles
CFT5-BK



Synthetic
FS-BK



Siam Oak, Synthetic
CFC-BK



Stainless steel jingles
HTA



Stainless steel jingles
PHTA



Synthetic
HSH

1 FOOT TAMBOURINE

MATERIALS Siam Oak (*Hevea brasiliensis* Muell.-Arg.)
Stainless steel jingles
FEATURE Hassle-free mounting

2 COMPACT FOOT TAMBOURINE

MATERIALS Synthetic
Stainless steel jingles
FEATURE Attaches quickly and easily to foot via elastic strap

3 CAJON FOOT TAMBOURINE

MATERIALS Siam Oak (*Hevea brasiliensis* Muell.-Arg.)
Stainless steel jingles
FEATURES 5 pairs of stainless steel jingles
Easily mountable

4 FOOT SHAKER

MATERIAL Synthetic
FEATURES Easy mountable
Shaker mounted at a special angle for precise control

5 CAJON FOOT CASTANET

MATERIALS Siam Oak (*Hevea brasiliensis* Muell.-Arg.)
Synthetic
FEATURES Traditional castanet sound
Easily mountable
Pair of synthetic castanets

6 HEEL TAMBOURINE

MATERIALS Siam Oak (*Hevea brasiliensis* Muell.-Arg.)
Synthetic
Stainless steel jingles
FEATURES Stainless steel jingles for a bright full sound
Shoehorn design fits comfortably against your heel
Great accessory for hands free playing

7 PROFESSIONAL HEEL TAMBOURINE

MATERIALS Siam Oak (*Hevea brasiliensis* Muell.-Arg.)
Synthetic
Stainless steel jingles
FEATURES Stainless steel jingles for a bright, full sound
Adjustable mounting system fits perfectly against your heel
Great accessory for hands-free playing



Siam Oak
FR1NT



Bendo seeds
FR1B



BENNY GREB SIGNATURE TAMBOSTEP
(SEE PAGE 82)



BG-TS



Kenen seeds
FR1K



Pangi seeds
FR1P

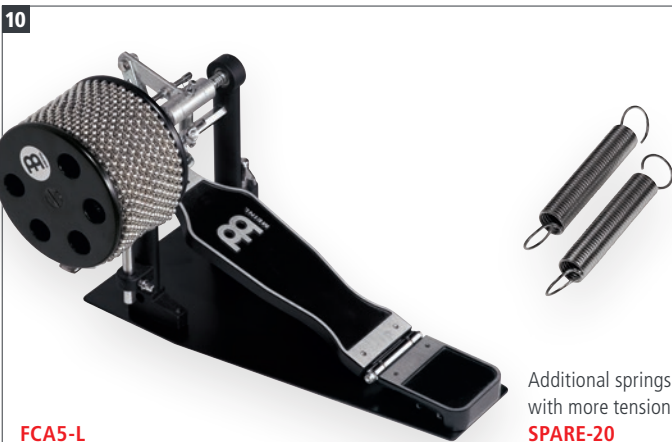

FCA5-L



Additional springs
with more tension
SPARE-20



Set, 2 pcs.
MPHS

USE YOUR FOOT TO EASILY
TAP ON THE TAMBOURINE

8 HEEL SHAKER

MATERIAL Synthetic
FEATURES Great accessory for hands-free playing
Shoehorn design fits comfortably against
your heel

9 FOOT RATTLES

MATERIALS **FR1NT:** Siam Oak
(*Hevea brasiliensis* Muell.-Arg.)
FR1B: Bendo seed nutshells
FR1K: Kenen seed nutshells
FR1P: Pangi seed nutshells
FEATURES Hands-free – straps securely and comfortably around your ankle
Creates a hollow wooden shaker effect with warmth and depth
Equipped with hook-and-loop strap for a universally adjustable fit

10 FOOT CABASA (PATENTED)

SIZE Large
MATERIALS Steel chain and stainless steel cylinder
Wooden body
Black powder coated pedal
FEATURES Optional single or double-stroke setting
5 sound ports on each side for more volume
INCLUDES Drum key
Foot pedal

11 TAMBOURINE HOLDER SET

MATERIAL Baltic Birch (*Betula pendula*)
CONTAINS Tambourine Holder
Headliner® Series Hand Held ABS
Tambourine (HTBK)
FEATURE Perfect for cajon players, guitarists and singers

DJEMBES





The djembe is a powerful and expressive hand drum with origins in West African culture, known for its rich tonal range and deep cultural significance. Crafted traditionally from wood and goat skin, this versatile instrument can produce booming bass, sharp slaps, and resonant tones, making it perfect for dynamic performances and drum circles. Whether you're playing traditional African rhythms or blending it into modern music, the djembe's voice adds an authentic, earthy energy. Easy to play yet full of depth, the djembe is a must-have for percussionists seeking to connect with rhythmic roots and global traditions.



ROPE TUNED TRAVEL & JR. DJEMBES

1 **PHARAOH'S SCRIPT**

SYNTHETIC HEAD 



14" **PADJ1-XL-F** 12" **PADJ1-L-F** 10" **PADJ1-M-F** 8" **PADJ1-S-F**

1 **KENYAN QUILT**

SYNTHETIC HEAD 



14" **PADJ2-XL-F** 12" **PADJ2-L-F** 10" **PADJ2-M-F** 8" **PADJ2-S-F**

1 **SIMBRA**

SYNTHETIC HEAD 



12" **PADJ5-L-F** 10" **PADJ5-M-F**

1 **KANGA SARONG**

SYNTHETIC HEAD 



12" **PADJ6-L-F** 10" **PADJ6-M-F**

1 **DAY OF THE DEAD**

SYNTHETIC HEAD 



12" **PADJ7-L-F** 10" **PADJ7-M-F**

1 ROPE TUNED TRAVEL SERIES DJEMBES, SYNTHETIC HEAD (PATENTED)

- SIZES**
- S:** 8" diameter, 16" tall
 - M:** 10" diameter, 20" tall
 - L:** 12" diameter, 24" tall
 - XL:** 14" diameter, 26" tall
- HTP ROPES**
- S:** 4 mm thickness, 20 runners
 - M:** 4 mm thickness, 25 runners
 - L:** 4 mm thickness, 30 runners
 - XL:** 5 mm thickness, 35 runners

- MATERIALS** Synthetic shell; Synthetic head
- FEATURES** 100% synthetic heads and shells are perfect for outdoor playing; Ultra light weight makes them easy to carry; Pre-stretched HTP nylon ropes; Produces sharp slaps and deep bass tones; Non-slip rubber bottom to protect the drum from scratches

- FINISHES**
- PADJ1:** Pharaoh's Script
 - PADJ2:** Kenyan Quilt
 - PADJ5:** Simbra
 - PADJ6:** Kanga Sarong
 - PADJ7:** Day of the Dead



2

HAND SELECTED GOATSKIN HEAD

HAND SELECTED GOATSKIN HEAD

PHARAOH'S SCRIPT

KENYAN QUILT

14" PADJ1-XL-G 12" PADJ1-L-G 10" PADJ1-M-G 8" PADJ1-S-G 14" PADJ2-XL-G 12" PADJ2-L-G 10" PADJ2-M-G 8" PADJ2-S-G



BLACK COLORED HAND SELECTED GOATSKIN HEAD

PHANTOM BLACK

12" PADJ4-L-G 10" PADJ4-M-G



3

Blue JRD-B Green JRD-G Yellow JRD-Y Orange JRD-O Red JRD-R

Black JRD-BK Twisted Amber JRD-TA Simbra JRD-SI Pharaoh's Script JRD-PS Kenyan Quilt JRD-KQ

2 ROPE TUNED TRAVEL SERIES DJEMBES, GOATSKIN HEAD (PATENTED)

- SIZES **S:** 8" diameter, 16" tall
M: 10" diameter, 20" tall
L: 12" diameter, 24" tall
XL: 14" diameter, 26" tall
- HTP ROPES **S:** 4 mm thickness, 20 runners
M: 4 mm thickness, 25 runners
L: 4 mm thickness, 30 runners
XL: 5 mm thickness, 35 runners
- MATERIALS Synthetic shell
PADJ1, PADJ2 Hand selected goatskin head
PADJ4 Black colored hand selected goatskin head

- FEATURES Goatskin heads give you authentic sound and feel; Synthetic shells are perfect for outdoor playing; Ultra light weight makes them easy to carry; Pre-stretched HTP nylon ropes; Produces sharp slaps and deep bass tones; Non-slip rubber bottom to protect the drum from scratches
- FINISHES **PADJ1:** Pharaoh's Script
PADJ2: Kenyan Quilt
PADJ4: Phantom Black

3 JR. DJEMBES

- SIZE 7" diameter, 12 1/2" tall
- ROPE 14 runners
- MATERIALS Synthetic shell; Synthetic head
- FEATURES Grab-and-go for any occasion, indoors or outside; Compact size and lightweight shell; Pre-stretched ropes; Produces sharp slaps and deep bass tones; 100% synthetic head and shell are perfect for outdoor playing
- COLORS **B:** Blue
BK: Black
G: Green
O: Orange
R: Red
Y: Yellow
- FINISHES **KQ:** Kenyan Quilt
PS: Pharaoh's Script
SI: Simbra
TA: Twisted Amber

JUMBO DJEMBES & COMMUNITY DRUMS



1 JUMBO DJEMBE SYNTHETIC HEADS

SIZES HEAD-JD10: 10"
HEAD-JD12: 12"
HEAD-JD14: 14"

MATERIALS Synthetic head

FEATURES For the Meinl Jumbo Djembe
100% synthetic all-weather head

FINISHES WH: White Fiberskin
Y: Yellow Fiberskin

2 JUMBO DJEMBES

SIZES JD10: 10" diameter, 20 1/2" tall
JD12: 12" diameter, 24" tall
JD14: 14" diameter, 26" tall

MATERIALS Synthetic shell
Synthetic head

FEATURES Jumbo size for deep bass tone
100% all-weather synthetic shell and head
Easy to use mechanical tuning system
Lightweight construction to travel easily

FINISHES BW: Barnwood
DA: Day of the Dead
SI: Simbra

3 COMMUNITY CONGAS

SIZES TU10SI: 10" diameter, 25 1/2" tall
TU12SI: 12" diameter, 25 1/2" tall
TU14SI: 14" diameter, 25 1/2" tall

MATERIALS Synthetic shell
Synthetic head

FEATURES Great for drum circles and students
Warm open tones
Indoor/outdoor
Easy to play and tune

FINISH SI: Simbra

4 COMMUNITY TIMBAU

SIZE 12" diameter, 23 1/2" tall

MATERIALS Synthetic shell
Synthetic head

FEATURES Great for drum circles and students
Warm open tones
Indoor/outdoor
Easy to play and tune

FINISH SI: Simbra

5 COMMUNITY TIMBA

SIZE 14" diameter, 39 1/2" tall

MATERIALS Synthetic shell
Synthetic head

FEATURES Great for drum circles and students
Warm open tones
Indoor/outdoor
Easy to play and tune

FINISH SI: Simbra

ALPINE & 3-IN-1 DJEMBES



DJEMBES & COMMUNITY DRUMS

1



BARNWOOD

12" **ADJ12-BW** 10" **ADJ10-BW**



DAY OF THE DEAD

12" **ADJ12-DA** 10" **ADJ10-DA**



KANGA SARONG

12" **ADJ12-KA** 10" **ADJ10-KA**



SIMBRA

12" **ADJ12-SI** 10" **ADJ10-SI**

2 PIEZO PICKUP AND VOLUME CONTROL



BARNWOOD

12" **PADJ12-BW**

3 MAY BE PLAYED BY THEMSELVES AS A SMALL HAND DRUM



12" **VR-POH12-SH** 10" **VR-POH10-SH**

12" **VR-POH12-NH** 10" **VR-POH10-NH**

4 STACKABLE FOR EASY STORAGE AND TRANSPORTATION



BOOM SERIES

Set, 3 pcs. **VR-SDJSET-SH**



SOFT SOUND SERIES

Set, 3 pcs. **VR-SDJSET-NH**

1 ALPINE SERIES DJEMBES

SIZES **ADJ10:** 10" diameter, 20" tall
ADJ12: 12" diameter, 24" tall

MATERIALS Synthetic shell
 Synthetic head

FEATURES Durable, synthetic head and shell
 Ultra light weight
 Mechanical tuning system
 Perfect for travel and outdoor performance

FINISHES **BW:** Barnwood
DA: Day of the Dead
KA: Kanga Sarong
SI: Simbra

FEATURES 100% synthetic djembe; Piezo pickup and volume control; Mechanically tuned head; Great for outdoor performances

FINISH **BW:** Barnwood

3 POP OFF HEADS

SIZES **VR-POH10:** 10" head diameter
VR-POH12: 12" head diameter

MATERIALS **SH:** Synthetic head
NH: Napa head

FEATURES Available as Napa style (soft sound) or standard synthetic (sharp sounds)
 Instantly take on or off your Meinl Pop Off Djembe
 May be played by themselves as a small hand drum
 Nylon-loop for easy removal
 Pre-tuned

4 3-IN-1 DJEMBES

SIZES 8" head diameter, 16 1/4" tall
 10" head diameter, 19 1/2" tall
 12" head diameter, 23" tall

MATERIALS Synthetic shell
SH: Synthetic head
NH: Napa head

FEATURES Synthetic shell is perfect for outdoor playing
 Non-slip rubber bottom
 Great for any skill level or style
 Stackable for easy storage and transportation
SH: Pre-tuned synthetic head for cutting sounds with sharp attack
NH: Pre-tuned Napa head creates softer, warmer sound

2 PICKUP ALPINE SERIES DJEMBE

SIZE 12" diameter, 24" tall

MATERIALS Synthetic shell
 Synthetic head

ROPE TUNED HEADLINER® WOOD DJEMBES



ROPE TUNED HEADLINER® SERIES WOOD DJEMBES 1 2 3 4

SIZES

- S:** 8" diameter, 15 3/4" tall
- M:** 10" diameter, 20" tall
- L:** 12" diameter, 24" tall
- XL:** 13" diameter, 25" tall

PP ROPES

- S:** 4 mm thickness, 16 runners
- M:** 4 mm thickness, 18 runners
- L:** 5 mm thickness, 20 runners
- XL:** 6 mm thickness, 24 runners

1 NILE SERIES

MATERIALS Mahogany Wood (*Swietenia macrophylla*)
Hand selected goatskin heads

FEATURES Carved from one solid piece of plantation grown Mahogany Wood
Pre-stretched PP nylon ropes
Hand carved shells

COLOR Brown

2 BLACK RIVER SERIES

MATERIALS Mahogany Wood (*Swietenia macrophylla*)
Hand selected goatskin heads

FEATURES Carved from one solid piece of plantation grown Mahogany Wood
Pre-stretched PP nylon ropes
Hand carved shells

COLOR Black

3 ARTIFACT SERIES

MATERIALS Mahogany Wood (*Swietenia macrophylla*)
Hand selected goatskin heads

FEATURES Carved from one solid piece of plantation grown Mahogany Wood
Pre-stretched PP nylon ropes
Hand carved shells

COLOR Brown

4 CONGO SERIES

MATERIALS Mahogany Wood (*Swietenia macrophylla*)
Hand selected goatskin heads

FEATURES Carved from one solid piece of plantation grown Mahogany Wood
Pre-stretched PP nylon ropes
Hand carved shells
Ornamental carving

COLOR Dark Brown

ROPE TUNED WOOD DJEMBES



5

BLACK COLORED HAND
SELECTED GOATSKIN HEADS

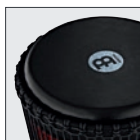

FIRE RHYTHM SERIES



13"
ADJ7-XL

12"
ADJ7-L

10"
ADJ7-M



WOOD DJEMBES

WATER RHYTHM SERIES



13", bundle with bag
ADJ2-XL+BAG

12", bundle with bag
ADJ2-L+BAG

10", bundle with bag
ADJ2-M+BAG

EARTH RHYTHM SERIES



13", bundle with bag
ADJ3-XL+BAG

12", bundle with bag
ADJ3-L+BAG

10", bundle with bag
ADJ3-M+BAG

5 ORIGINAL AFRICAN STYLE ROPE TUNED WOOD DJEMBES

SIZES
M: 10" (9 1/4" - 10 1/4") diameter, 20" tall
L: 12" (10 3/4" - 12 1/4") diameter, 24" tall
XL: 13" (12 3/4" - 13 3/4") diameter, 25" tall

HTP ROPES
M: 4 mm thickness, 25 runners
L: 4 mm thickness, 35 runners
XL: 5 mm thickness, 35 runners

MATERIALS
 Mahogany Wood (*Swietenia macrophylla*)
 Hand selected goatskin heads

FEATURES
 Carved from one solid piece of plantation grown Mahogany Wood
 Pre-stretched HTP nylon ropes
 Hand carved shells
 Ornamental carving

ADJ7

Black colored hand selected goatskin heads
 Colored rope wrapping

INCLUDES ADJ2, ADJ3
 Professional Djembe Bag made out of heavy-duty padded nylon

COLORS
ADJ2: Brown
ADJ3: Brown/Black
ADJ7: Black

PROFESSIONAL, ARTISAN EDITION & MINI DJEMBES

1 SPECIAL "VILLAGE" CARVING  **NEW**



12" **PROADJ2-L** 10" **PROADJ2-M** 12" **PROADJ5-L** 10" **PROADJ5-M**

2 COLORED ORNAMENTAL CARVING 



12" **AE-DJTC2-L**

3 

DJTH

4



Python Design, 4 1/2" **HDJ5-XXS** Dark Serpent Design, 4 1/2" **HDJ6-XXS**

Gecko Design, 4 1/2" **HDJ7-XXS** Flower Design, 4 1/2" **HDJ8-XXS**

STANDARD DJEMBE BAGS (SEE PAGE 131)



MSTDJB10 **MSTDJB12**



1 PROFESSIONAL AFRICAN STYLE DJEMBES

SIZES **M:** 10" (9 1/4" - 10 1/4") diameter, 20" tall
L: 12" (10 3/4" - 12 1/4") diameter, 24" tall

HTP ROPES **M:** 4 mm thickness, 25 runners
L: 4 mm thickness, 35 runners

MATERIALS Mahogany Wood (*Swietenia macrophylla*)
Hand selected goatskin heads

FEATURES Carved from one solid piece of plantation grown Mahogany Wood; Pre-stretched HTP nylon ropes

COLORS **PROADJ2:** "Village" carving
PROADJ2: Brown
PROADJ5: Natural

FEATURES Carved from one solid piece of plantation grown Mahogany Wood; Pre-stretched HTP nylon ropes; Hand carved shell; Colored ornamental carving

COLOR Brown

FINISHES **HDJ5:** Python Design
HDJ6: Dark Serpent Design
HDJ7: Gecko Design
HDJ8: Flower Design

2 ARTISAN EDITION TONGO CARVED DJEMBE

SIZE 12" (10 3/4" - 12 1/4") diameter, 24" tall

HTP ROPE 5 mm thickness, 30 runners

MATERIALS Mahogany Wood (*Swietenia macrophylla*)
Hand selected goatskin head

3 DJEMBE TUNING HAMMER

MATERIAL Baltic Birch (*Betula pendula*)

FEATURES Use to tighten the tension on rope tuned djembes; Great for on-the-spot tuning adjustments

5 HEADLINER® SERIES WOOD DJEMBES

SIZE 12 1/2" diameter, 25 1/4" tall

MATERIALS Siam Oak (*Hevea brasiliensis* Muell.-Arg.)
Hand selected goatskin head

FEATURES 8 mm strong tuning lugs; 2.6 mm rounded rims; Original Meinl style tuning brackets; Black powder coated hardware; Sleek Hourglass shape for more comfort

INCLUDES Tuning key

COLORS **NT:** Natural, high gloss
VWB-M: Vintage Wine Barrel, matte

4 AFRICAN STYLE MINI DJEMBES

SIZE 4 1/2" (4 1/4" - 4 3/4") diameter, 8" tall

PP ROPE 3 mm thickness, 10 runners

MATERIALS Mahogany Wood (*Swietenia macrophylla*)
Hand selected goatskin head

FEATURES Carved from one solid piece of plantation grown Mahogany Wood; High quality PP nylon rope; Hand painted shell

HEADLINER® & FLOATUNE WOOD DJEMBES



WOOD DJEMBES

5 ORIGINAL MEINL STYLE TUNING BRACKETS

Vintage Wine Barrel, 12 1/2" **HDJ500VWB-M**

Natural, 12 1/2" **HDJ500NT**

6 FLOATUNE TUNING AVOIDS THE NEED TO DRILL THROUGH THE SHELL

Gold Amber Sunburst, 12" **DJW3GAB-M**

Natural, 12" **DJW3NT**

7 FLOATUNE TUNING SYSTEM

Zebra Finished Ash, 12" **DJW3ZFA-M**

8 DESIGNER DJEMBE STRAPS

Day of the Dead **MDJS1DA** Kanga Sarong **MDJS1KA** Kenyan Quilt **MDJS1KQ** Pharaoh's Script **MDJS1PS** Simbra **MDJS1SI**

9 PROFESSIONAL SHOULDER STRAP

MDJS2

6 FLOATUNE SERIES WOOD DJEMBES
SIZE 12" diameter, 24 1/4" tall
MATERIALS Siam Oak (*Hevea brasiliensis* Muell.-Arg.) True Skin Goat Head
FEATURES 8 mm strong tuning lugs; 3 mm rounded SSR-Rims; Easy tuning and comfortable change of heads; Rubber pads and lug placement offer perfect playing comfort; Floatune Tuning System; Chrome plated hardware
INCLUDES Accessory pouch; L-shaped tuning key; Tune Up Oil
COLORS **GAB-M:** Gold Amber Sunburst, matte **NT:** Natural, high gloss

FEATURES 8 mm strong tuning lugs; 3 mm rounded SSR-Rims; Easy tuning and comfortable change of heads; Rubber pads and lug placement offer perfect playing comfort; Floatune Tuning System; Chrome plated hardware
INCLUDES Accessory pouch; L-shaped tuning key; Tune Up Oil
COLOR Zebra Finished Ash, matte

COLORS **DA:** Day of the Dead **KA:** Kanga Sarong **KQ:** Kenyan Quilt **PS:** Pharaoh's Script **SI:** Simbra

7 FLOATUNE SERIES WOODCRAFT DJEMBE
SIZE 12" diameter, 24 1/4" tall
MATERIALS American White Ash (*Fraxinus americana* L.) True Skin Goat Head

8 DESIGNER DJEMBE STRAPS
MATERIAL Heavy-duty nylon
FEATURES Holds your djembe in a secure playing position; For standing djembe players; Heavy-duty synthetic fabric that lasts; Adjustable webbed PP straps for a comfortable fit

9 PROFESSIONAL SHOULDER STRAP
MATERIAL Heavy-duty nylon
FEATURES Holds any djembe or other drums in perfect playing position; Length adjustable; Adjustable shoulder padding; Quick change hook
COLOR Black

TAMBOURINES FRAME DRUMS

Tambourines and frame drums are timeless percussion instruments found in cultures around the world, known for their simplicity and expressive sound. The tambourine, with its jingling metal zills, adds a bright, rhythmic shimmer to any musical ensemble, while the frame drum, often featuring a single drumhead, produces deep, resonant tones. Both instruments are incredibly versatile, used in everything from folk and classical music to contemporary styles. Whether you're looking to add a rhythmic accent or a rich, earthy foundation, tambourines and frame drums offer dynamic, hand-played percussion for musicians of all levels.



COMPACT WOOD TAMBOURINES

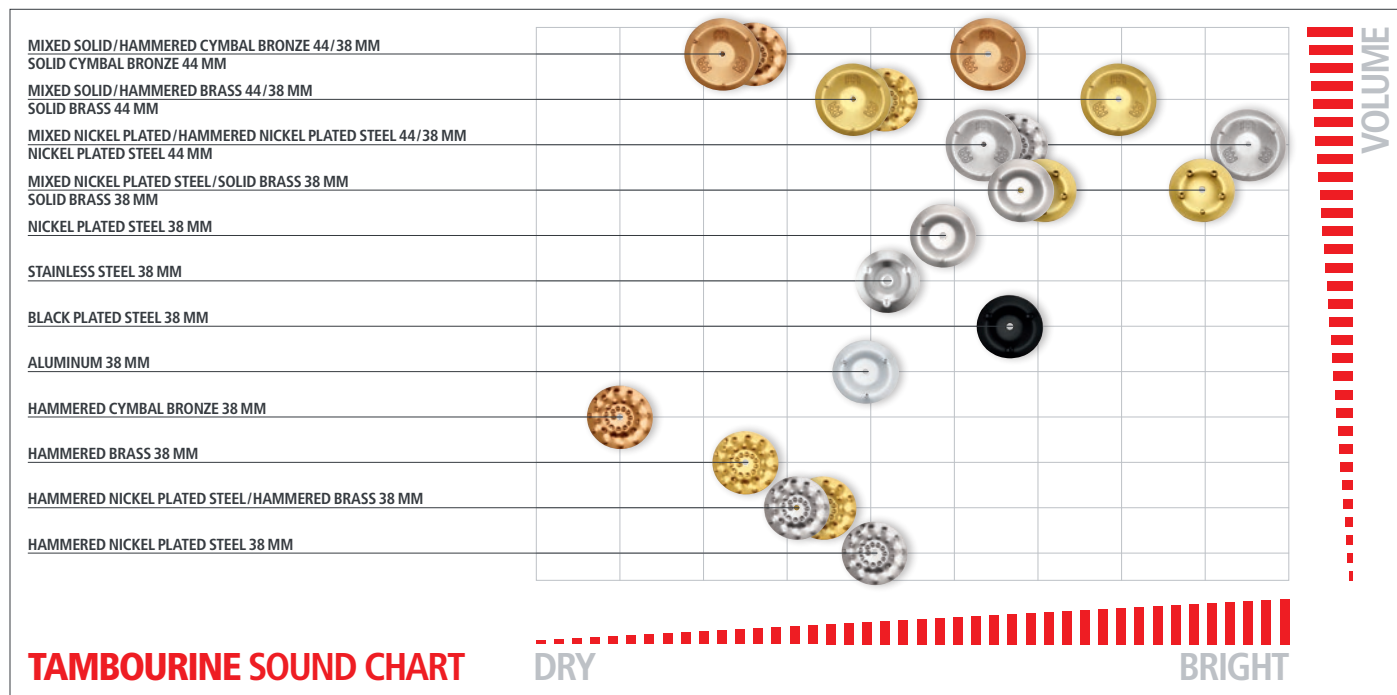

<p>1</p>  <p>HAMMERED CYMBAL BRONZE</p> <p>3 rows AE-CMTA3BO</p>	<p>2</p>  <p>SOLID BRASS</p> <p>2 rows CTA2B-BK</p>	 <p>MIXED NICKEL PLATED STEEL / SOLID BRASS</p> <p>2 rows CTA2M-BK</p>	 <p>NICKEL PLATED STEEL</p> <p>2 rows CTA2S-BK</p>
 <p>HAMMERED BRASS</p> <p>3 rows AE-CMTA3B</p>	 <p>HAMMERED NICKEL PLATED STEEL</p> <p>3 rows AE-CATA3S</p>	 <p>MIXED HAMMERED NICKEL PLATED STEEL / BRASS</p> <p>2 rows CTA2VM-WB</p>	 <p>STAINLESS STEEL</p> <p>2 rows CTA2WB</p>

1 ARTISAN EDITION COMPACT TAMBOURINES

SIZE 8"

MATERIALS **AE-CATA3:** American White Ash (*Fraxinus americana* L.)
AE-CMTA3: Maple (*Adcer* sp.)
B: Hammered brass jingles
BO: Hammered cymbal bronze jingles
S: Hammered nickel plated steel jingles

FEATURES Total unique tambourine sounds; Resounding jingle accents; Special profile jingles; Ergonomic hand grip; Detailed with ornamental heat-branded logo; 3 rows of hammered jingles; Extra narrow jingle slots for precise playing

2 COMPACT WOOD TAMBOURINES

SIZE 8"

MATERIALS Wooden frame
CTA2B-BK: Solid brass jingles
CTA2M-BK: Nickel plated steel / solid brass jingles
CTA2S-BK: Nickel plated steel jingles
CTA2VM-WB: Hammered nickel plated steel / hammered brass jingles
CTA2WB: Stainless steel jingles

FEATURES Compact size; 2 row version

COLORS **BK:** Black
WB: Walnut Brown

3 ARTISAN EDITION TAMBOURINES

SIZE 10"

MATERIALS **AE-ATA:** American White Ash (*Fraxinus americana* L.)
AE-MTA: Maple (*Adcer* sp.)
B: Solid brass jingles
BO: Solid cymbal bronze jingles
S: Nickel plated steel jingles

FEATURES Total unique tambourine sounds; Resounding tambourine accents; Special profile jingles; Ergonomic hand grip; Detailed with ornamental heat-branded logo; 1 row and 2 row version

WOOD TAMBOURINES



TAMBOURINES

3

1 row
AE-MTA1B0

2 rows
AE-MTA2B0

SOLID CYMBAL
BRONZE 44 MM

1 row
AE-MTA1B

2 rows
AE-MTA2B

SOLID BRASS 44 MM

1 row
AE-ATA1S

2 rows
AE-ATA2S

NICKEL PLATED
STEEL 44 MM

4

1 row
TA1V-WB

2 rows
TA2V-WB

HAMMERED BRASS

1 row
TA1B-AB

2 rows
TA2B-AB

SOLID BRASS

1 row
TA1AB

2 rows
TA2AB

NICKEL
PLATED STEEL

1 row
TA1VM-WB

2 rows
TA2VM-WB

MIXED
HAMMERED NICKEL
PLATED STEEL / BRASS

1 row
TA1WB

2 rows
TA2WB

STAINLESS STEEL

1 row
TA1A-AB

2 rows
TA2A-AB

ALUMINUM

6

1 row
TA1M-SNT

2 rows
TA2M-SNT

MIXED
NICKEL PLATED
STEEL / SOLID BRASS

4 VINTAGE WOOD TAMBOURINES

SIZE 10"

MATERIALS Wooden frame
TA1V: Hammered brass jingles
TA1VM: Hammered nickel plated steel / hammered brass jingles

FEATURES Legendary tambourine sound; Special profile jingles; Detailed with heat-branded logo; 1 row and 2 row version

COLOR **WB:** Walnut Brown

5 TRADITIONAL WOOD TAMBOURINES

SIZE 10"

MATERIALS Wooden frame
TA1A-AB, TA2A-AB: Aluminum jingles
TA1B-AB, TA2B-AB: Solid brass jingles
TA1AB, TA2AB: Nickel plated steel jingles
TA1WB, TA2WB: Stainless steel jingles

FEATURES 1 row and 2 row version
TA1WB, TA2WB: Detailed with heat-branded logo

COLORS **AB:** Antique Brown
WB: Walnut Brown

6 RECORDING-COMBO WOOD TAMBOURINES

SIZE 10"

MATERIALS Wooden frame
 Nickel plated steel / solid brass jingles

FEATURES Dual-alloy jingles; 1 row and 2 row version

COLOR **SNT:** Super Natural

HEADED WOOD TAMBOURINES

<p>1</p>  <p>MIXED SOLID / HAMMERED CYMBAL BRONZE</p> <p>2 rows AE-MTAH2BO</p>	 <p>MIXED SOLID / HAMMERED BRASS</p> <p>2 rows AE-MTAH2B</p>	 <p>MIXED NICKEL PLATED / HAMMERED NICKEL PLATED STEEL</p> <p>2 rows AE-ATAH2S</p>	<p>2</p>  <p>TAMBURELLO</p> <p>2 rows FD12TAM</p> <p>ALUMINUM</p>
<p>3</p>  <p>HAMMERED BRASS</p> <p>1 row TAH1V-WB</p> <p>2 rows TAH2V-WB</p>	<p>4</p>  <p>BLACK PLATED STEEL</p> <p>1 row TAH1BK-R-TF</p> <p>2 rows TAH2BK-R-TF</p>	<p>5</p>  <p>MIXED NICKEL PLATED STEEL / SOLID BRASS</p> <p>1 row TAH1M-SNT</p> <p>2 rows TAH2M-SNT</p>	
<p>6</p>  <p>SOLID BRASS</p> <p>1 row TAH1B-AB</p> <p>2 rows TAH2B-AB</p>	 <p>NICKEL PLATED STEEL</p> <p>1 row TAH1AB</p> <p>2 rows TAH2AB</p>	 <p>STAINLESS STEEL</p> <p>1 row TAH1WB</p> <p>2 rows TAH2WB</p>	 <p>ALUMINUM</p> <p>1 row TAH1A-AB</p> <p>2 rows TAH2A-AB</p>

1 HEADED ARTISAN EDITION TAMBOURINES

SIZE 10"

MATERIALS Hand selected calfskin heads
AE-ATAH: American White Ash (*Fraxinus americana* L.)
AE-MTAH: Maple (*Adcer sp.*)
B: Solid / hammered brass jingles
BO: Solid / hammered cymbal bronze jingles
S: Nickel plated / hammered nickel plated steel jingles

FEATURES Total unique tambourine sounds; Resounding jingle accents; Two different profile jingles; Ergonomic hand grip; Detailed with ornamental heat-branded logo; Prepared with Resin

2 TAMBURELLO

SIZE 12"

MATERIALS Wooden frame; Hand selected goatskin head; Aluminum jingles

FEATURES 2 row version; Detailed with heat-branded logo; Total unique tambourine sounds

3 VINTAGE GOATSKIN WOOD TAMBOURINES

SIZE 10"

MATERIALS Wooden frame; Hand selected goatskin heads; Hammered brass jingles

FEATURES 1 row and 2 row version; Detailed with heat-branded logo

COLOR **WB:** Walnut Brown

4 TOURING SYNTHETIC HEAD WOOD TAMBOURINES

SIZE 10"

MATERIALS Wooden frame; True Feel synthetic heads; Black plated steel jingles

FEATURE 1 row and 2 row version
COLOR **R:** Red

5 RECORDING-COMBO GOATSKIN WOOD TAMBOURINES

SIZE 10"

MATERIALS Wooden frame; Hand selected goatskin heads; Nickel plated steel / solid brass jingles

FEATURES Dual-alloy jingles; 1 row and 2 row version

COLOR **SNT:** Super Natural

6 TRADITIONAL GOATSKIN WOOD TAMBOURINES

SIZE 10"

MATERIALS Wooden frame; Hand selected goatskin heads
TAH1A-AB, TAH2A-AB: Aluminum jingles

HAND HELD ABS TAMBOURINES



TAMBOURINES

7



1 row, 8"
HTT8BK

2 rows, 10"
HTT10BK



1 row, 8"
HTT8R

2 rows, 10"
HTT10R



1 row, 8"
HTT8WH

2 rows, 10"
HTT10WH

STAINLESS STEEL

8



1 row
HTBK

2 rows
HTMT1BK



1 row
HTR

2 rows
HTMT1R



1 row
HTWH

2 rows
HTMT1WH

STAINLESS STEEL

9



2 rows
TMT1B-BK

SOLID BRASS



2 rows
TMT1BK

NICKEL PLATED STEEL



2 rows
TMT1R

NICKEL PLATED STEEL



2 rows
TMT1A-B

ALUMINUM

10



2 rows
TMT1M-BK

MIXED NICKEL PLATED STEEL / SOLID BRASS



2 rows
TMT1M-WH

TAH1B-AB, TAH2B-AB:

Solid brass jingles

TAH1AB, TAH2AB:

Nickel plated steel jingles

TAH1WB, TAH2WB:

Stainless steel jingles

FEATURES 1 row and 2 row version

TAH1WB, TAH2WB: Detailed with heat-branded logo

COLORS **AB:** Antique Brown

WB: Walnut Brown

7 HEADLINER® SERIES TOUR TAMBOURINES

SIZES **HTT8:** 8"
HTT10: 10"

MATERIALS Molded ABS; Stainless steel jingles

FEATURES Handheld; Extra wide grip; Bright, cutting sound; Durable frame

HTT8: 1 row version; Compact size

HTT10: 2 row version

COLORS **BK:** Black
R: Red
WH: White

8 HEADLINER® SERIES HAND HELD ABS TAMBOURINES

MATERIALS Molded ABS; Stainless steel jingles

FEATURES Ergonomic hand grip for more playing comfort; Güiro style playing surface; Penetrating jingle sound

HT: 1 row version

HTMT1: 2 row version

COLORS **BK:** Black
R: Red
WH: White

9 TRADITIONAL HAND HELD ABS TAMBOURINES

MATERIALS Molded ABS
TMT1A-B: Aluminum jingles

TMT1B-BK: Solid brass jingles

TMT1BK, TMT1R: Nickel plated steel jingles

FEATURES Padded soft grip for more playing comfort; Ergonomic design; Güiro style playing surface; "Sandwich" construction

COLORS **B:** Blue
BK: Black
R: Red

10 RECORDING-COMBO HAND HELD ABS TAMBOURINES

MATERIALS Molded ABS; Nickel plated steel / solid brass jingles

FEATURES Padded soft grip for more playing comfort; Ergonomic design; Güiro style playing surface; "Sandwich" construction

COLORS **BK:** Black
WH: White

MOUNTABLE ABS TAMBOURINES

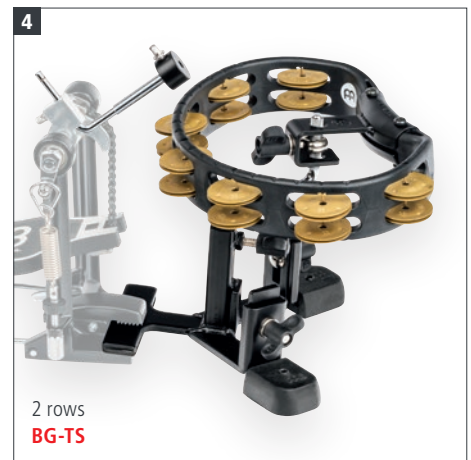
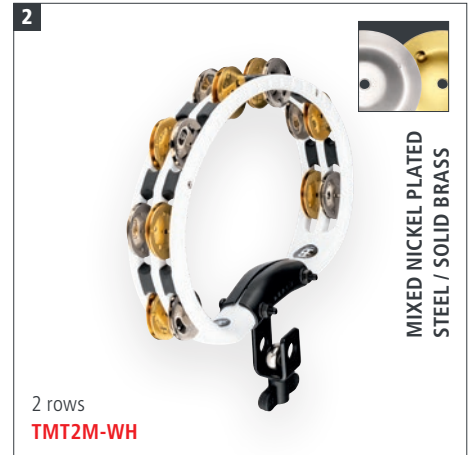

1 HEADLINER® SERIES MOUNTABLE ABS TAMBOURINES

MATERIALS Molded ABS
Stainless steel jingles

FEATURES Easy mountable
Güiro style playing surface
Penetrating jingle sound

COLORS **BK:** Black
R: Red
WH: White

2 RECORDING-COMBO MOUNTABLE ABS TAMBOURINE

MATERIALS Molded ABS
Nickel plated steel / solid brass jingles

FEATURES Easily mountable
Ergonomic design
Güiro style playing surface
"Sandwich" construction

COLOR **WH:** White

3 TRADITIONAL MOUNTABLE ABS TAMBOURINES

MATERIALS Molded ABS
TMT2A-B: Aluminum jingles
TMT2B-BK: Solid brass jingles
TMT2BK, TMT2R: Nickel plated steel jingles

FEATURES Easily mountable
Ergonomic design
Güiro style playing surface
"Sandwich" construction

COLORS **B:** Blue
BK: Black
R: Red

4 BENNY GREB SIGNATURE TAMBOSTEP

MATERIAL Sand blasted brass jingles

FEATURES Designed with Benny Greb
Hands-free tambourine
Great for multi-instrumentalists, guitarists, and cajon players

INCLUDES Pedal Mount (PM-1); Special designed Z-shaped rod and beater

CHING RINGS & HIHAT TAMBOURINES



TAMBOURINES

1



Ching Ring
CRING

STAINLESS STEEL



Dry Ching Ring
DCRING

ZINC



Soft Ching Ring
SCRING

STAINLESS STEEL

2



SFHHT

3



1 row
HTHH1B-BK

HAMMERED BRASS



2 rows
HTHH2B-BK

HAMMERED BRASS

4



1 row
THH1B-BK

SOLID BRASS



1 row
HTHH1BK

STAINLESS STEEL



2 rows
HTHH2BK

STAINLESS STEEL

4



1 row
THH1BK

STAINLESS STEEL

5



1 row
HTHHBG

SAND HIHAT TAMBOURINE
DESIGNED WITH BENNY GREB

6



TMTH

STAINLESS STEEL

1 CHING RINGS

SIZE 6"

MATERIALS **CRING**
Steel ring
5 pairs of stainless steel jingles

DCRING
Steel ring
5 pairs of zinc jingles

SCRING
Foam ring
6 pairs of stainless steel jingles

FEATURES Fits on most cymbals
Quick setup

2 SUPER FLEX HIHAT TAMBOURINE

SIZE 4.3" inner diameter, 9.5" outer diameter

MATERIALS Mylar frame
10 pairs of stainless steel jingles

FEATURES Super flex frame produces enhanced hihat tambourine accents

10 pairs of stainless steel jingles deliver a clear and bright sound
Extra-wide 9.5" shape gives you outstanding foot response
Shines through the mix to easily blend a tambourine effect into your grooves

3 HEADLINER® SERIES HIHAT TAMBOURINES

SIZE 5"

MATERIALS **HTHH1BK, HTHH2BK:**
Stainless steel jingles
HTHH1B-BK, HTHH2B-BK:
Hammered brass jingles

FEATURE 1 row and 2 row version

4 PROFESSIONAL SERIES HIHAT TAMBOURINES

SIZE 5"

MATERIALS **THH1BK:** Stainless steel jingles
THH1B-BK: Solid brass jingles

FEATURE Rubber padded surface

5 BENNY GREB SAND HIHAT TAMBOURINE

SIZE 5"

MATERIAL Sand blasted brass jingles

FEATURES Benny Greb signature hihat tambourine
Eight pairs of sand blasted brass jingles
Dry, vintage sound with unique matte appearance
Blends easily into your natural drum set or percussion mix
Wing nut design fits on any hihat rod

6 TAMBOURINE HIHAT

SIZE 5"

MATERIAL Stainless steel jingles

FEATURES Top and bottom pieces work like hihats
Great for low volume kits
Sturdy steel frame

CRASHERS, BACKBEAT TAMBOURINES & JINGLE STICKS



1 TURBO CRASHERS

SIZES **CRASHER-M**: Medium
CRASHER: Large

MATERIAL Steel

FEATURES Güiro style playing surface; Cutting sound; Easy mountable

2 BACKBEAT TAMBOURINES

SIZES **BBT1-BK**: For 10" and 12" drums
BBT2-BK: For 13" and 14" drums

MATERIALS Eco-friendly medium density fiberboard; Stainless steel jingles

FEATURES Fits on any standard drum; Adds a tambourine sound to the groove; Hook and loop fastener

COLOR **BK**: Black

3 BACKBEAT PRO TAMBOURINE

SIZE 14"

MATERIALS Cymbal brass alloy ring; Solid brass jingles

FEATURES Blackened brass ring made from Meinl Cymbal Alloy; Eight pairs of solid brass jingles

4 HEADLINER® SERIES JINGLE STICKS

MATERIALS Molded ABS; Stainless steel jingles

COLORS **BK**: Black
R: Red

5 PROFESSIONAL SERIES JINGLE STICKS

MATERIALS Molded ABS
JG1: Nickel plated steel jingles
JG1A: Aluminum jingles
JG1B: Solid brass jingles
JG1M: Nickel plated steel / solid brass jingles

FEATURES Padded grip; Güiro style playing surface

6 MULTI-JINGLE STICK

MATERIALS Molded ABS; Nickel plated steel / solid brass jingles

FEATURES Jingles mounted on two intersecting planes
Padded grip; Special playing techniques

ARTISAN EDITION RIQ DRUM & PANDEIROS



1

Synthetic head, 8 3/4"
AERIQ1

2

CHROME PLATED STEEL JINGLES

Clear Mylar head, 10"
PA10ABS-BK

Napa head, 10"
PA10ABS-BK-NH

3

CHROME PLATED STEEL JINGLES

Poplar Wood, 10"
PA10PW-M

Siam Oak, 10"
PA10CN-M

PANDEROS DE PLENA
(SEE PAGE 39)

10"
PL10CW

12"
PL12CW

14"
PL14CW

4

HAND-HAMMERED BRASS JINGLES

Goatskin head, 10"
PA10AB-M

Siam Oak, 12"
PA12CN-M

5

UNIQUE SHAKER PODS

Napa head, 10"
PAS10PW-NH

6

EASY MOUNTABLE

Napa head, 10"
PA10A-BK-NH-H

- 1 ARTISAN EDITION RIQ DRUM**
 SIZE 8 3/4"
 MATERIALS Wooden frame; Synthetic head;
 Ten pairs of brass jingles
 FEATURES Artisan sounds for Arabic folk and
 classical music; Five tuning lugs
 INCLUDES Tuning key; Bag
 FINISH White Pearl Mosaic Royale
- 2 TRADITIONAL ABS PANDEIROS**
 SIZE 10"
 MATERIALS Molded ABS; Chrome plated steel jingles
PA10ABS-BK
 Replaceable synthetic head
PA10ABS-BK-NH
 Replaceable Napa head
 FEATURES Countersunk bolt lugs
PA10ABS-BK: Logo applied from under-
 neath the head (CN, TH, US patent)
PA10ABS-BK-NH: Reduced overtones

- INCLUDES Tuning key
 COLOR **BK:** Black
- 3 TRADITIONAL WOOD PANDEIROS**
 SIZES **PA10:** 10"
PA12: 12"
 MATERIALS Replaceable hand selected goatskin head;
 Chrome plated steel jingles
PA10CN-M, PA12CN-M
 Siam Oak (*Hevea brasiliensis* Muell.-Arg.)
PA10PW-M
 Poplar Wood (*Populus*)
 INCLUDES Tuning key
 COLOR **CN-M:** Chestnut, matte
- 4 SHELL-TUNED PANDEIRO**
 SIZE 10"
 MATERIALS Siam Oak (*Hevea brasiliensis* Muell.-Arg.)
 Hand selected goatskin head;
 Hand-hammered brass jingles

- INCLUDES Hex key
 COLOR **AB-M:** Antique Brown, matte
- 5 SHAKER PANDEIRO**
 SIZE 10"
 MATERIALS Poplar Wood (*Populus*); Replaceable
 Napa head; Aluminum shaker pods
 FEATURE Countersunk bolt lugs
 INCLUDES Tuning key
- 6 TRADITIONAL ABS PANDEIRO WITH HOLDER**
 SIZE 10"
 MATERIALS Molded ABS; Replaceable Napa head;
 Chrome plated steel jingles
 FEATURES Countersunk bolt lugs; Reduced overtones;
 Easy mountable
 INCLUDES Tuning key
 COLOR **BK:** Black

FRAME DRUMS



1 HAND DRUMS

SIZES **HD10:** 10"; **HD12:** 12"; **HD14:** 14";
HD16: 16"; **HD18:** 18"

MATERIALS Siam Oak (*Hevea brasiliensis* Muell.-Arg.)
AB: Hand selected goatskin head
AB-TF: True Feel synthetic head

COLOR Antique Brown

2 TARS

SIZES **FD16:** 16", 2 1/2" deep
FD18: 18", 2 1/2" deep
FD20: 20", 2 1/2" deep
FD22: 22", 2 1/2" deep

MATERIALS Siam Oak (*Hevea brasiliensis* Muell.-Arg.)
T: Hand selected goatskin head
T-TF: True Feel synthetic head

FEATURE Internal tuning system

INCLUDES Hex key

COLOR Antique Brown, matte

3 ARTISAN EDITION TARS (PATENTED)

SIZES **AE-FD14:** 14", 2 1/2" deep
AE-FD18: 18", 2 1/2" deep
AE-FD22: 22", 2 1/2" deep

MATERIALS Siam Oak (*Hevea brasiliensis* Muell.-Arg.)
Hand selected goatskin head

FEATURES Special designed bearing edge (DE, US patent); Internal tuning system

INCLUDES Hex key

COLOR Walnut Brown, matte

4 SEA DRUMS

SIZES **FD16:** 16", 2 3/4" deep
FD18: 18", 2 3/4" deep
FD20: 20", 2 3/4" deep
FD22: 22", 2 3/4" deep

MATERIALS Siam Oak (*Hevea brasiliensis* Muell.-Arg.)
Transparent synthetic head and
SD: Hand selected goatskin head
SD-TF: True Feel synthetic head

FEATURES Steel balls inside; Sealable filling port

COLOR Antique Brown, matte

5 MIZHARS

SIZES **FD14:** 14", 4" deep
FD18: 18", 4" deep

MATERIALS Siam Oak (*Hevea brasiliensis* Muell.-Arg.)
T-D: Hand selected goatskin head
T-D-TF: True Feel synthetic head

FEATURES Deep shell construction for full sound development; Internal tuning system

INCLUDES Hex key

COLOR Brown Burl, matte

6 ARTISAN EDITION MIZHARS (PATENTED)

SIZES **AE-FD14:** 14", 4" deep
AE-FD18: 18", 4" deep
AE-FD22: 22", 4" deep

MATERIALS Siam Oak (*Hevea brasiliensis* Muell.-Arg.)
Hand selected goatskin head

5 **HAND SELECTED GOATSKIN HEADS**

18" x 4"
FD18T-D

14" x 4"
FD14T-D

TRUE FEEL SYNTHETIC HEADS

18" x 4"
FD18T-D-TF

14" x 4"
FD14T-D-TF

6

22" x 4"
AE-FD22T-D

18" x 4"
AE-FD18T-D

14" x 4"
AE-FD14T-D

7 **HAND SELECTED GOATSKIN HEADS**

16" x 2 1/2"
FD16BE

14" x 4"
FD14BE

TRUE FEEL SYNTHETIC HEADS

16" x 2 1/2"
FD16BE-TF

14" x 4"
FD14BE-TF

8 **METAL RINGS FOR SPECIAL EFFECTS**

20" x 2 1/2"
FD20D-TF

9 **CROSS BAR**

18" x 4"
FD18B0

10 **DAMPENING LAYER FOR LESS OVERTONES**

14" x 6"
FD14IB0

11 **TUNING KEY INCLUDED**

7 1/2"
FD7KA

12 **NYLON BAG INCLUDED**

Set, 4 pcs.
PL-SET

FEATURES Special designed bearing edge (DE, US patent); Internal tuning system
INCLUDES Hex key
COLOR Walnut Brown, matte

7 BENDIRS

SIZES **FD14:** 14", 4" deep
FD16: 16", 2 1/2" deep
MATERIALS Siam Oak (*Hevea brasiliensis* Muell.-Arg.)
BE: Hand selected goatskin head
BE-TF: True Feel synthetic head
FEATURES Internal tuning system; Buzzing effect
INCLUDES Hex key
COLOR Antique Brown, matte

8 DAF

SIZE 20", 2 1/2" deep
MATERIALS Siam Oak (*Hevea brasiliensis* Muell.-Arg.)
 True Feel synthetic head

FEATURE Metal rings for special effects
COLOR Antique Brown, matte

BODHRANS 9 10

MATERIALS Siam Oak (*Hevea brasiliensis* Muell.-Arg.)
 Hand selected goatskin head
INCLUDES Hex key

9 CELTIC BODHRAN

SIZE 18", 4" deep
FEATURES Cross bar; Internal tuning system
COLOR Antique Brown, matte

10 IRISH BODHRAN

SIZE 14", 6" deep
FEATURES Extra deep shell for full sound development; Dampening layer around rim for reduced overtones
COLOR Brown Burl, matte

11 KANJIRA

SIZE 7 1/2", 2 1/4" deep
MATERIALS Siam Oak (*Hevea brasiliensis* Muell.-Arg.)
 Hand selected goatskin head
FEATURES Many sound options; Set of 3 jingles
INCLUDES Hex key
COLOR Antique Brown, matte

12 PLENERA SET

SIZES 8" Quinto; 10" Seguidor; 12" Tumbador
MATERIALS ABS molded frames; Goatskin heads
FEATURE External mechanical lug tuning
INCLUDES Nylon Bag; Tuning Key

HAND PERCUSSION



Hand percussion instruments like shakers, kalimbas, castanets, and chimes bring subtle yet essential rhythms to a wide range of musical styles. These small, easy-to-play instruments offer a delicate and precise way to enhance the groove, adding texture and color to your sound. From the crisp shake of a maraca to the sharp click of claves, hand percussion creates dynamic layers that enrich both live performances and studio recordings. Whether you're a seasoned percussionist or a beginner, these instruments are perfect for adding a rhythmic pulse and driving the energy of any musical piece.



SHAKERS & TAMBOURINES

1

<p>SOFT: STUDIO</p> <p>Studio shaker, Red SH5R</p> <p>72 - 76 DB</p>	<p>MEDIUM: LIVE</p> <p>Live shaker, Black SH4BK</p> <p>79 - 81 DB</p>	<p>MEDIUM: LIVE</p> <p>Live shaker, Creamsicle SH4CS</p>	<p>MEDIUM: LIVE</p> <p>Live shaker, Electric Coral SH4EC</p>
<p>MEDIUM: LIVE</p> <p>Live shaker, Glacier Blue SH4GB</p>	<p>MEDIUM: LIVE</p> <p>Live shaker, Seafoam Green SH4SF</p>	<p>MEDIUM: LIVE</p> <p>Live shaker, White SH4WH</p>	<p>LOUD: STADIUM</p> <p>Stadium shaker, Grey SH45GR</p> <p>88 - 93 DB</p>

2

MSS

3

Set, 3 pcs.
PP-1

4

Set, 4 pcs.
ES-SET-2

5

SOFT

MEDIUM

LOUD

EXTRA LOUD

Set, 4 pcs.
ES-SET

6

COMES IN A SET OF TWO

Black **ES2-BK**

Red **ES2-R**

Blue **ES2-B**

Yellow **ES2-Y**

Green **ES2-GREEN**

1 ARTIST SERIES SHAKERS LUIS CONTE

SIZE Medium

MATERIAL Synthetic

FEATURES Two individual shakers connected as one instrument

SH4: Perfect for live playing

SH45: Perfect for stadium situations

SH5: Perfect for studio recordings

COLORS

BK: Black

CS: Creamsicle

EC: Electric Coral

GB: Glacier Blue

GR: Grey

R: Red

SF: Seafoam Green

WH: White

2 LUIS CONTE SHAKER WITH STRAPS

SIZE Medium

MATERIAL Synthetic

FEATURES Strap to a drumstick to get shaker sounds as you play

Add new sonic layers to your drum set grooves

COLOR **BK:** Black

INCLUDES Two durable rubber straps

3 PERC PACK

CONTAINS Compact Foot Tambourine

Luis Conte Live Shaker

Classic Wood Claves

FEATURES Compact Foot Tambourine for hands free use

Luis Conte Live Shaker for smooth sound

Classic Wood Claves for traditional rhythms

4 EGG SHAKER ASSORTMENT

MATERIAL Synthetic

FEATURES Four-piece egg shaker set ideal for any percussion set up

Designed for four different volume levels

Color coded for easy identification

Easily transportable

5 EGG SHAKER SET

MATERIAL Synthetic

FEATURE Range of volume from soft to extra loud

6 EGG SHAKER PAIRS

MATERIAL Synthetic

FEATURE Comes in a set of two

COLORS

B: Blue

BK: Black

GREEN: Green

R: Red

Y: Yellow



Set, 24 pcs.
ES-SET24-BK

Set, 24 pcs.
ES-SET24-MC



Set, 60 pcs.
ES-BOX



Happy Face
FACE-H

Laughing Face
FACE-L

Face Shaker Assortment, 24 pcs.
FSA1

Face Shaker Assortment, 4 pcs.
FSA4

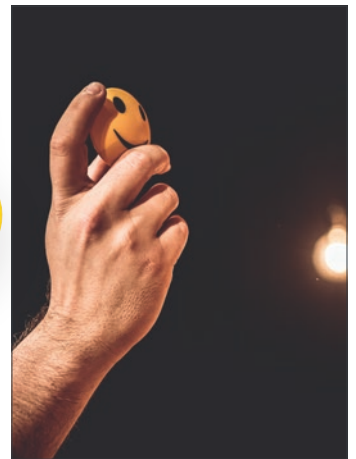

Key Ring Tambourine, Red
KRT-R

Key Ring Tambourine, Black
KRT-BK

Key Ring Shaker and Tambourine Assortment
KRA1

Key Ring Shaker, Grey
KRS-GR

Key Ring Shaker, Black
KRS-BK

7 EGG SHAKER SETS OF 24 PCS.

MATERIAL Synthetic
FEATURES Crystal clear shaker sounds
Durable shells
Great for group or classroom percussion
COLORS **BK:** Black
MC: Multi-color

8 EGG SHAKER BOX

CONTAINS Holds 60 Egg Shakers:
20 x Egg Shaker, Blue (B)
10 x Egg Shaker, Black (BK)
10 x Egg Shaker, Green (GREEN)
10 x Egg Shaker, Red (R)
10 x Egg Shaker, Yellow (Y)

9 FACE SHAKERS

MATERIAL Molded ABS
CONTAINS **FSA1**
6 x Happy Face
6 x Laughing Face
6 x Poop Face
6 x Sad Face
FSA4
1 x Happy Face
1 x Laughing Face
1 x Poop Face
1 x Sad Face
FEATURES Made of durable molded ABS
Loud filling projects clearly
Great accent for live and studio applications
INCLUDES **FSA1:** Fishbowl
GRAPHICS **FACE-H:** Happy Face
FACE-L: Laughing Face

10 KEY RING SHAKERS & KEY RING TAMBOURINES

MATERIALS Molded ABS
KRT: Nickel plated steel
CONTAINS **KRA1**
10 x Key Ring Shaker
8 x Key Ring Tambourine
FEATURES Easily detach when it's time to play
Perfect for acoustic shows or jam sessions
INCLUDES **KRA1:** Fishbowl
FINISHES **BK:** Black
GR: Grey
R: Red

SHAKERS

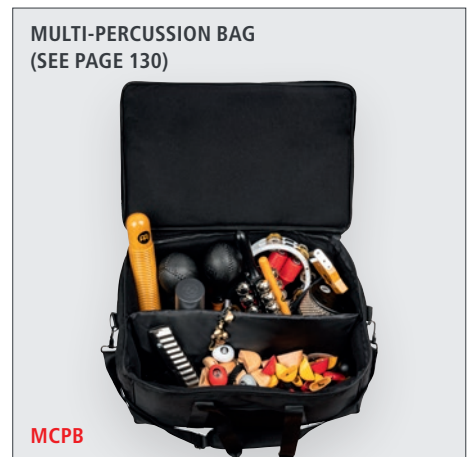
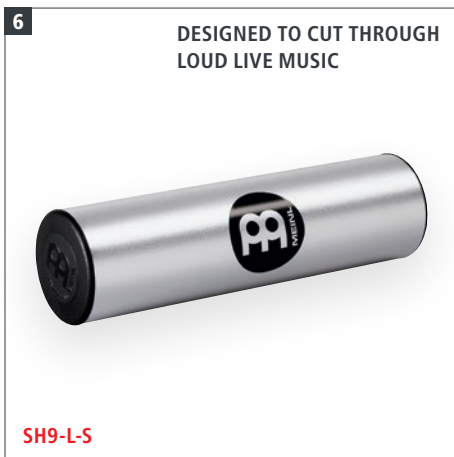
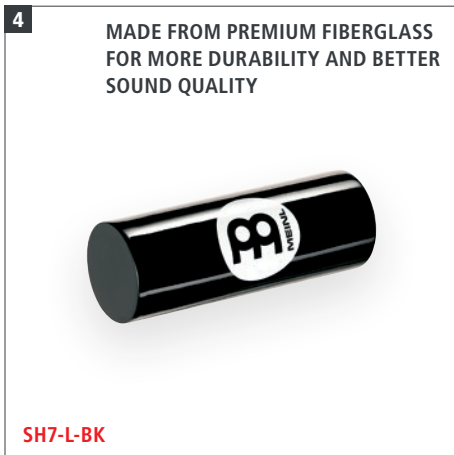

1 STUDIO SHAKERS

SIZES **SH10-M-BK**: Medium
SH10-L-BK: Large

MATERIAL Synthetic

FEATURE Deliver a very tasteful and delicate shaker sound with a warm tone and well balanced frequency spectrum

COLOR **BK**: Black

2 STUDIOMIX SHAKERS

SIZES **SH12-M-BK**: Medium
SH12-L-BK: Large

MATERIAL Synthetic

FEATURE Textured surface for special sound and positive grip

COLOR **BK**: Black

3 CRYSTAL SHAKERS

SIZE Large

MATERIALS Synthetic; Acrylic

FEATURES Shapes any groove with clarity and feel
SH26-L-L: Perfect for live playing
SH26-L-S: Perfect for studio recordings

4 FIBERGLASS SHAKER

SIZE Large

MATERIAL Premium fiberglass

FEATURE Made from premium fiberglass for more durability and better sound quality

COLOR **BK**: Black

5 ALUMINUM SHAKERS, OCTAGONAL

SIZES **SH8BK**: Small
SH88BK: Medium
SH888BK: Large

MATERIAL Aluminum

FEATURE Provides a broad dynamic range with lots of volume

COLOR **BK**: Black

6 ALUMINUM SHAKER, ROUND

SIZE Large

MATERIAL Anodized aluminum

FEATURE Designed to cut through loud live music

COLOR **S**: Silver

8 CIRCULAR MOTION ENABLES A UNIQUE RATTLING



Spark shaker
SH16

SENSATIONAL EFFECTS ARE PRODUCED WHEN COMBINED WITH ANOTHER SPARK SHAKER



9 SCREW-MOUNTED DISC ENABLES A TUNABLE PITCH



Spin spark
SH17

10



Headed spark
SH18

MOTION SHAKER
(SEE PAGE 61)



MS-BK

11



Medium
SH20BK

BY COVERING AND UNCOVERING THE SOUND HOLE, A "WAH-WAH" EFFECT CAN BE ACHIEVED

12 LOUD AND PENETRATING SOUND DUE TO THE MANY HOLES



SH3BK

13



Black
SH21BK

7 PROJECTION SHAKER

SIZE Large
MATERIAL Anodized aluminum
FEATURES For comfort and volume; Shimmering, cutting pitch; Exceptional for live playing
COLOR **S:** Silver

9 ORIGINAL SPARK SHAKER

SIZE Medium
MATERIALS Shaker: Coated steel
Pellets: Coated steel
FEATURES Circular motion enables a unique rattling; Spark Shakers may be played in pairs
FINISH Black nickel

10 SPIN SPARK SHAKER

SIZE Medium
MATERIALS Shaker: Coated steel
Pellets: Coated steel
FEATURE Screw-mounted disc enables a tunable pitch
FINISH Black nickel

11 HEADED SPARK SHAKER

SIZE Medium
MATERIALS Shaker: Coated steel
Pellets: Coated steel
Goatskin head
FEATURES Premium goatskin and a steel shell provide a rattling combination; Swirling effect; Variable pitch
FINISH Black nickel

12 WAKAH SHAKER

SIZE Medium
MATERIALS Wooden body and synthetic chamber
FEATURE By covering and uncovering the sound hole, a "wah-wah" effect can be achieved
COLOR **BK:** Black

13 LOOP SHAKER

SIZE Medium
MATERIAL Synthetic
FEATURE Loud and penetrating sound due to the many holes
COLOR **BK:** Black

14 U.F.O. SHAKER

SIZE Medium
MATERIAL Synthetic
COLOR **BK:** Black

SHAKERS

1



Baltic Birch
SH50

Ovangkol
SH51

CUTTING SHAKER SOUND

2



Set, 3 pcs.
SH50-SET

DIFFERENT FILLINGS

3

EXOTIC ZEBRANO TOP AND BOTTOM



Small
SH53-S

Medium
SH53-M

4



Burl Wood
SH60

DUAL INTERNAL CHAMBERS

5

SOFT



Lime
SH56



6



Double Shaker
D01

Ganza
GA2

MEDIUM

LOUD



Beech
SH58

Oak
SH59

7



Small
CAX1

Medium
CAX2

Large
CAX3

1 MINI CAJON SHAKERS

SIZE 2" W x 2 3/4" H x 2" D

MATERIALS Resonating body: Baltic Birch (*Betula pendula*)
SH50
Frontplate: Baltic Birch (*Betula pendula*)
SH51

FEATURES Compact size; Cutting shaker sound; Miniature size of a Meinl cajon

2 MINI CAJON SHAKER SET

MATERIALS Resonating body: Baltic Birch (*Betula pendula*)
Frontplates: Exotic Zebrano, Burl Wood, Baltic Birch (*Betula pendula*)

FEATURES Three unique timbres for multiple sound options; Various frontplates for easy identification

3 WOOD SHAKERS, RECTANGLE

SIZES **S:** Small
M: Medium

MATERIALS Baltic Birch (*Betula pendula*)
Top and Bottom: Exotic Zebrano

FEATURES Wide sound options; Rectangle shaped

4 DUAL CHAMBER SHAKER

MATERIAL Baltic Birch Plywood (*Betula pendula*)
Top and Bottom: Burl Wood

FEATURES Dual internal chambers for greater shaker control; Easier to play consistent shaker patterns; Ultra-smooth sound

5 WOOD SHAKERS, ROUND

SIZE 4" length, 1 3/4" diameter

MATERIALS **SH56:** Lime
SH58: Beech
SH59: Oak

FEATURES Made from three wood species for different volume; Fits comfortably in your hand
SH56: Soft
SH58: Medium
SH59: Loud

6 DOUBLE SHAKER & GANZA

MATERIALS Rattan with coconut bottom

FEATURES **D01:** Offers two different sounds in one instrument
GA2: Crystal clear sound, high pitched with a great projection

7 CAXIXIS

SIZES **CAX1:** Small
CAX2: Medium
CAX3: Large

MATERIALS Rattan with coconut bottom

FEATURES Crystal clear sound, high pitched with a great projection; Woven by hand

KALIMBAS & CASTANETS



Small
KA5-S

Medium
KA9-M

Medium
KA7-M-BK



WIDE OPENING FOR GREAT WAH-WAH EFFECTS

KA9WW-BK



Coral Reef
KA17CR

Lava
KA17LV

Sun
KA17SU



BUILT-IN PICKUP

PKA17AW



SEPARATELY ADJUSTABLE

CM2

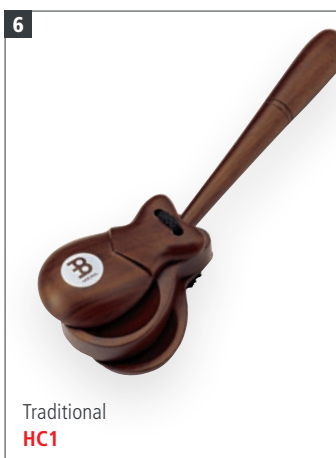

Traditional
HC1



Traditional
FC1

Concert
FC2

1 SOLID KALIMBAS

SIZES **KA5-S**: Small
KA7-M-BK, KA9-M: Medium
MATERIALS New Zealand Pine (*Pinus radiata*)
TUNING **KA5-S**: g#, c', f', f', c''
KA7-M-BK: e', g, d'', e, c', a, a'
KA9-M: a', c', c', a', A, f', e', e'', b'
FEATURES **KA5-S, KA9-M**: Heat-branded logo
KA7-M-BK: Extra wide tongues

2 WAH-WAH KALIMBA

MATERIALS New Zealand Pine (*Pinus radiata*)
TUNING a', c', c', a', A, f', e', e'', b'
COLOR **BK**: Black

3 SOUND HOLE DESIGNER KALIMBAS

MATERIALS **KA17CR, KA17LV**: Acacia
KA17SU: Sapele
TUNING C Major: d'', b', g', e', c', a, f, d, c, e, g, b, d', f', a', c'', e'' (17 notes)
FEATURES Easy for all skill levels
INCLUDES Travel case; Microfiber cleaning cloth; Tuning hammer
DESIGNS **CR**: Coral Reef; **LV**: Lava; **SU**: Sun

4 SOLID PICKUP KALIMBA

MATERIALS American Walnut
TUNING C Major: d'', b', g', e', c', a, f, d, c, e, g, b, d', f', a', c'', e'' (17 notes)
FEATURES Easy for all skill levels; Built-in pickup
INCLUDES Travel case; Microfiber cleaning cloth; Tuning hammer

5 CASTANET MACHINE

SIZE 7 1/2" x 5"
MATERIAL Indian Rosewood
FEATURES Separately adjustable; Full and cutting resonance

6 TRADITIONAL HAND CASTANET

SIZE Traditional
MATERIAL Indian Rosewood

7 FINGER CASTANETS

SIZES **FC1**: Traditional
FC2: Concert
MATERIAL Indian Rosewood

SOUND EFFECTS

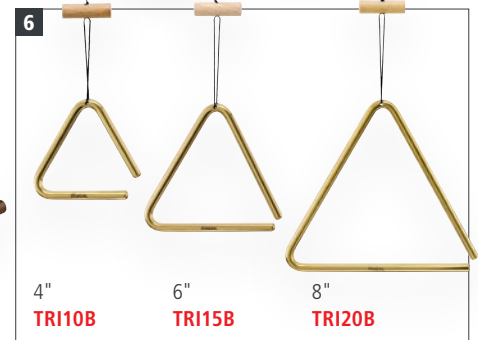

1 BIRDS & WATERFALLS

MATERIALS **B15:** Bendo seed nutshells
WA5: Pangi seed nutshells
B17RY, WA7BK: Premium fiberglass
B11NT, WA1NT, B12NT, WA2NT: Siam Oak (*Hevea brasiliensis* Muell.-Arg.)

FEATURES Durable cord
BI: Realistically imitate the sound of a flock of birds; Bright sound with big dynamic range
WA: Realistically imitate the sound of a rippling waterfall; Clear, crisp sound

COLORS **BK:** Black
B15, WA5: Brown
NT: Natural
RY: Red/Yellow

2 AJUCH BELLS

SIZES 30" long
MABS: Small bells
MABM: Medium bells
MABL: Large bells

MATERIAL Brass and synthetic wax

FEATURES Cast bells; Solid hook for easy attachment; Synthetic wax rope

INCLUDES Canvas pouch for safe and simple storage

COLORS **MABS:** Brown and Turquoise
MABM: Black
MABL: Dark Red and Gold

3 KOKIRIKO

MATERIAL Wood

FEATURES Ergonomically shaped handle; Durable cord

COLOR **AM:** Amber

4 ORCHESTRA RATCHET

MATERIALS Chrome plated steel
Hood Pine Tines

FEATURES Produce quick notes like a cabasa or long-sustaining rattle effects; Wooden internal paddles project clearly; Easy to grip metal hand crank; Mountable on a stand

5 WOODEN FROGS

SIZES **M:** Medium; **L:** Large

FEATURE Authentic "ribbit" sound

6 TRIANGLES

SIZES **TRI10B:** 4"
TRI15B: 6"
TRI20B: 8"

MATERIAL Solid brass

INCLUDES Wooden holder with braided nylon cord
Metal beater



27 bells
BT27



14 bells
BT14



FICY-14

SPECIAL BRONZE ALLOY

SOUND EFFECTS



PFICY-2



FICY-2



BOWL



GALAXY

VERY FUNKY



TRIL

FILLED WITH WATER



WW2BK



25 bells
SLB25

12 bells
SLB12

7 bells
SLB7

STEEL BELLS



N11AM

7 STAND ALONE BELL TREE

MATERIAL Solid brass bells
FEATURE Adjustable metal stand
INCLUDES Striker

8 HAND HELD BELL TREE

MATERIAL Solid brass bells
INCLUDES Striker

9 HANGING FINGER CYMBALS

SIZES 2 3/8" diameter
MATERIAL Special bronze alloy
FEATURES Shimmering sound; Durable cord

10 PROFESSIONAL FINGER CYMBALS

SIZE 2 5/8" diameter
MATERIAL Special bronze alloy
FEATURES Identical, high pitched sound; Durable cord

11 ORIENTAL FINGER CYMBALS

SIZE 2 3/8" diameter
MATERIAL Special bronze alloy

BILL SARAGOSA LINE 12 13 14

MATERIAL Special steel alloy
FEATURE Wide sound spectrum
INCLUDES Metal beater
FINISH Black nickel

12 HELIX BOWL

FEATURES Wonderful instrument consisting of a steel helix welded to a resonating chamber; Deep resonating wah-wah effect

13 GALAXY

FEATURES Two resonant liquid chambers are connected by a long steel spiral liquid; Inside the two chambers exerts variable dampening on the steel resonator plates

14 LIQUID TRIANGLE

FEATURES Special steel alloy, filled with water

15 WAH-WAH TUBE

SIZE Large (low pitch)
MATERIAL Aluminum
INCLUDES Rubber mallet
COLOR **BK:** Black

16 SLEIGH BELLS

SIZES **SLB7:** 7 bells; **SLB12:** 12 bells; **SLB25:** 25 bells
MATERIALS Steel bells; Wooden handle
FEATURES Ergonomic grip; True sleigh bell sound

17 THE NIGHT

MATERIALS Solid steel balls and cylinder
Wooden body
COLOR **AM:** Amber

CHIMES

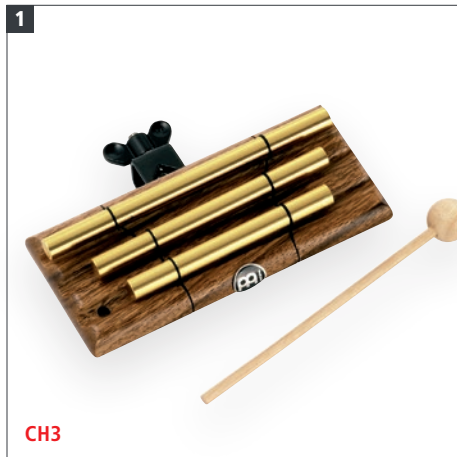

CH3



12 bars
CH-H12

18 bars
CH-H18

24 bars
CH-H24



12 pegs
CH-HPEG



27 bars, single row
HCH1R



33 bars, single row
HCH2BK

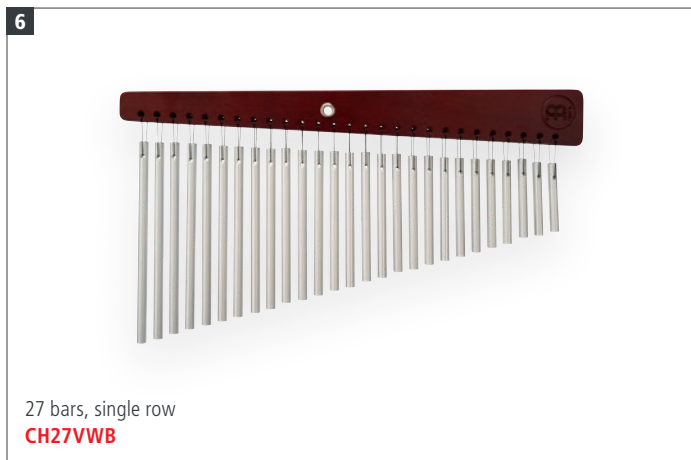

27 bars, single row
CH27VWB



33 bars, single row
CH33VWB

1 TRI TONE CHIMES

- MATERIAL** Gold anodized aluminum alloy
- FEATURES** Three free-floating bars create a very long sustain
Tonally matched bars
Mountable on all common L-rods
- INCLUDES** Wooden beater and holder

2 HAND CHIMES

- SIZES** **CH-H12:** 12 bars
CH-H18: 18 bars
CH-H24: 24 bars
- MATERIAL** Gold anodized aluminum alloy
- FEATURES** Can easily be played by hand
Produce a full and rich sound

3 PEG CHIMES

- SIZE** 12 pegs
- MATERIAL** Gold plated steel
- FEATURE** Perfect for special accents

4 HEADLINER® SERIES CHIMES, 27 BARS

- SIZE** 27 bars, single row
- MATERIAL** Silver anodized aluminum alloy
- FEATURES** Great and affordable addition to any percussion set-up
Produce a full and warm chime sound
- COLOR** **R:** Red

5 HEADLINER® SERIES CHIMES, 33 BARS

- SIZE** 33 bars, single row
- MATERIAL** Silver anodized aluminum alloy
- FEATURE** Generate a full sound spectrum
- COLOR** **BK:** Black

6 VINTAGE CHIMES, 27 BARS

- SIZE** 27 bars, single row
- MATERIAL** Silver anodized aluminum alloy
- FEATURE** Excellent addition to any drum or percussion arrangement
- COLOR** **VWB:** Vintage Wine Barrel

7 VINTAGE CHIMES, 33 BARS

- SIZE** 33 bars, single row
- MATERIAL** Silver anodized aluminum alloy
- FEATURES** Can be used in a wide range of musical styles
Producing a sweet sparkling sound
- INCLUDES** Holder; Striker
- COLOR** **VWB:** Vintage Wine Barrel

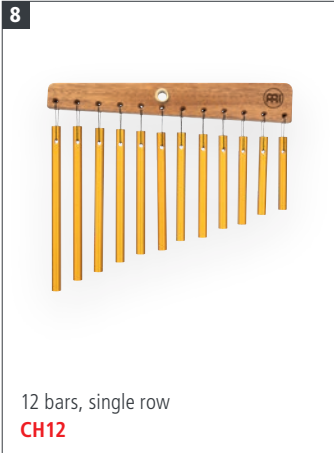

12 bars, single row
CH12

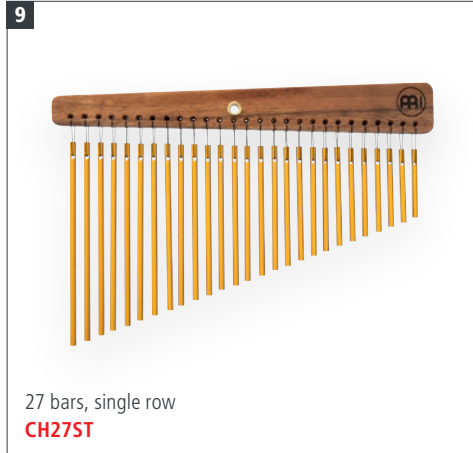

27 bars, single row
CH27ST



27 bars, single row
CH27

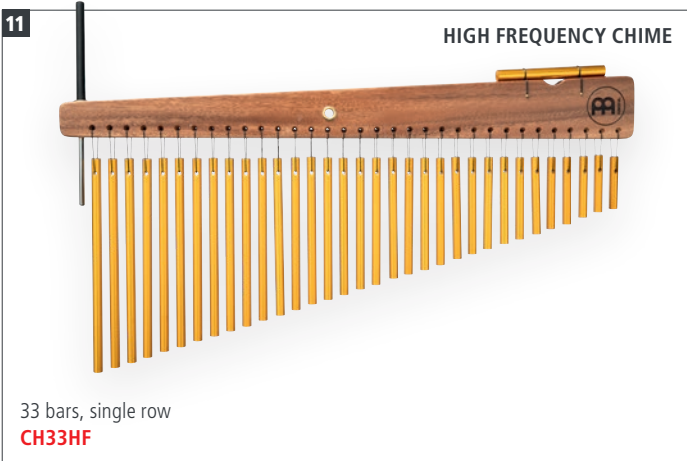

33 bars, single row
CH33HF

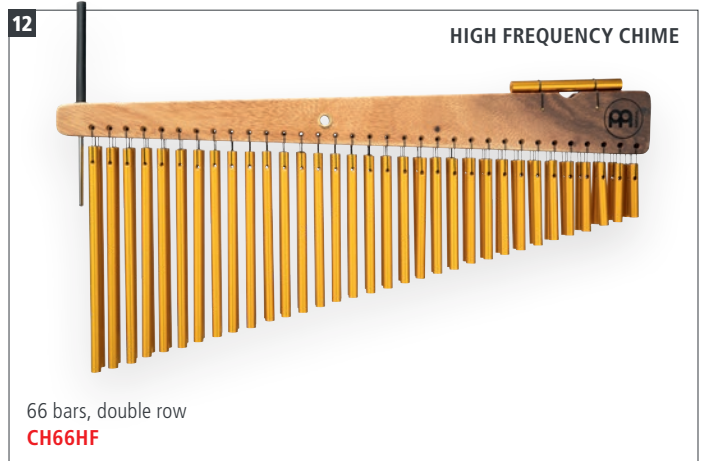

66 bars, double row
CH66HF

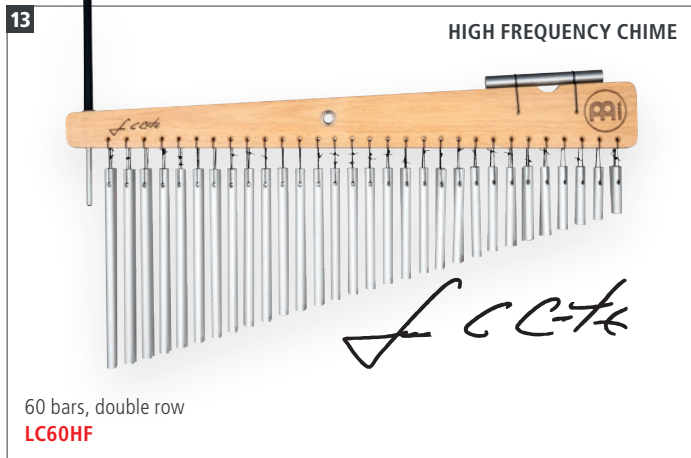

60 bars, double row
LC60HF



LUIS CONTE

8 CHIMES, 12 BARS

SIZE 12 bars, single row
MATERIAL Gold anodized aluminum alloy
FEATURES Produce a beautiful, high pitched sound
Ideal for tasteful chime accents

9 STUDIO CHIMES, 27 BARS

SIZE 27 bars, single row
MATERIAL Gold anodized aluminum alloy
FEATURE Slightly thinner bars for a full, rich and delicate sound

10 CHIMES, 27 BARS

SIZE 27 bars, single row
MATERIAL Gold anodized aluminum alloy
FEATURES Produce a full sound with a wide tonal spectrum
Ideal for smaller stages and club scenes

11 CHIMES, 33 BARS

SIZE 33 bars, single row
MATERIAL Gold anodized aluminum alloy
FEATURES Produce a very bright sound with a pronounced upper overtone spectrum
Perfect for all live situations
High frequency chime
INCLUDES Holder; Striker

12 CHIMES, 66 BARS

SIZE 66 bars, double row
MATERIAL Gold anodized aluminum alloy
FEATURES Produces a rich and full sound
Cut through any band setting
High frequency chime
INCLUDES Holder; Striker

13 ARTIST SERIES CHIMES LUIS CONTE

SIZE 60 bars, double row
MATERIAL Silver anodized aluminum alloy
FEATURES Produces a bright sound from the medium and low pitched bars
Perfect for all studio situations
High frequency chime
INCLUDES Holder; Striker

DIDGERIDOOS

1

COLORFUL HAND-PAINTED ACCENTS HARKEN TO TRADITIONAL NATIVE AUSTRALIAN DESIGNS

47" **DDG1-BK**

47" **DDG1-BR**

47" **DDG1-R**

2

51" **SDDG1-BK**

S-Shape, 51" **SDDG2-BK**

3

TWO TELESCOPING SECTIONS

36"-62" **TSDDG1-BK**

<p>1 WOOD DIDGERIDOOS</p> <p>SIZE 47"</p> <p>MATERIAL Bamboo</p> <p>TUNING DDG1-BK: E DDG1-BR: D# DDG1-R: E</p> <p>COLORS BK: Black BR: Brown R: Red</p>	<p>2 SYNTHETIC DIDGERIDOOS</p> <p>SIZE 51"</p> <p>MATERIAL Lightweight synthetic</p> <p>TUNING SDDG1-BK: D SDDG2-BK: C#</p> <p>FEATURES SDDG2-BK "S" shaped body for bigger sounds Distinctive, full drone and harmonic overtones</p> <p>COLOR BK: Black</p>	<p>3 TROMBONE DIDGERIDOO</p> <p>SIZE 36"-62"</p> <p>MATERIAL Premium fiberglass</p> <p>TUNING from: G#, G, F#, F, E, D#, D, C#, C</p> <p>FEATURE Two telescoping sections for variable pitch</p> <p>COLOR BK: Black</p>
---	---	---



60"
TSDDG2-BK



57"
PROFDDG1-BK



57"
PROSDDG1-BK



61"
SDDG1-SI



8 1/2" x 5"
DDG-BOX



SMALL IN SIZE BUT BIG IN SOUND



100% PURE BEESWAX
DDG-MP

4 SYNTHETIC SLIDE TRAVEL DIDGERIDOO
SIZE Portable: 24"; Playable: 60"
MATERIAL Lightweight synthetic
TUNING D
FEATURES Contractible body for easy travel
 Distinctive, full drone and harmonic overtones
INCLUDES Bag
COLOR **BK:** Black

5 PRO FIBERGLASS DIDGERIDOO
SIZE 57"
MATERIAL Premium fiberglass
TUNING D
COLOR **BK:** Black

6 PRO SYNTHETIC DIDGERIDOO
SIZE 57"
MATERIAL Lightweight synthetic
TUNING D
COLOR **BK:** Black

7 ARTIST SERIES DIDGERIDOO SIMON "SI" MULLUMBY
SIZE 61"
MATERIAL Premium fiberglass
TUNING F
COLOR Grey

8 TRAVEL DIDGERIDOO (US PATENT)
SIZE 8 1/2" x 5"
MATERIAL Mahogany Wood (*Swietenia macrophylla*)
TUNING C
FEATURES Heat-branded logo
 Compact size

9 DIDGERIDOO MOUTHPIECE
SIZE Inner diameter: 30 mm
 Outer diameter: 60 mm
MATERIAL Antiseptic beeswax
FEATURES Easy mountable
 100% pure beeswax
 Fits perfect on our didgeridoos

RAINSTICKS & RAINMAKER

1

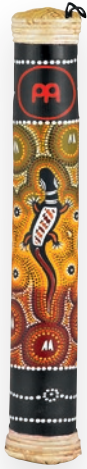

16"
RS1BK-S

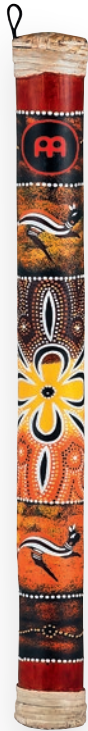

24"
RS1R-M



31 1/2"
RS1BK-M/L

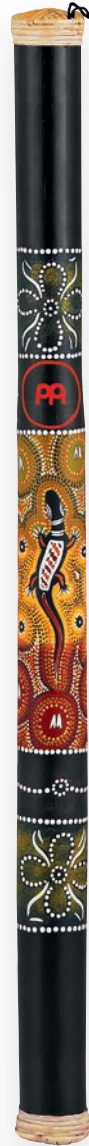

39"
RS1BK-L



47"
RS1BK-XL



60"
RS1BK-XXL



1 WOOD RAINSTICKS

SIZES
S: 16"
M: 24"
M/L: 31 1/2"
L: 39"
XL: 47"
XXL: 60"
MATERIAL Bamboo
COLORS **BK:** Black
R: Red

2 SYNTHETIC RAINSTICK

SIZE **L:** 39"
MATERIAL Lightweight synthetic
COLOR **R:** Red

3 PRO RAINSTICK

SIZE **XL:** 47"
MATERIAL Rattan wrapped Bamboo
FEATURES Long susurration
 Authentic rain sounds

4 PRO RAINMAKER

SIZE 3 3/4" W x 25 1/4" H x 3 3/4" D
MATERIAL Baltic Birch (*Betula pendula*)
FEATURES Ultra long sustain
 Authentic rain sound
 Natural birch wood construction
COLOR **NT:** Natural



SAMBA

A close-up, artistic photograph of a metal percussion instrument, likely a surdo or pandeiro. The instrument's metal body and a vertical rod are in sharp focus, while the background is filled with soft, out-of-focus bokeh lights in warm tones of gold and orange, creating a vibrant and atmospheric setting.

Samba percussion instruments are the heartbeat of Brazil's vibrant music, driving the lively rhythms that define this iconic genre. Instruments like the surdo, tamborim, and pandeiro create the powerful, syncopated beats that bring energy to Samba performances, from street parades to stage shows. Each instrument plays a unique role, blending deep, resonant bass with sharp, bright tones to form the intricate layers of Samba's rhythmic pulse. Whether you're playing in a Samba band or exploring its infectious rhythms on your own, these instruments offer an exciting, dynamic way to experience the spirit of Brazil.

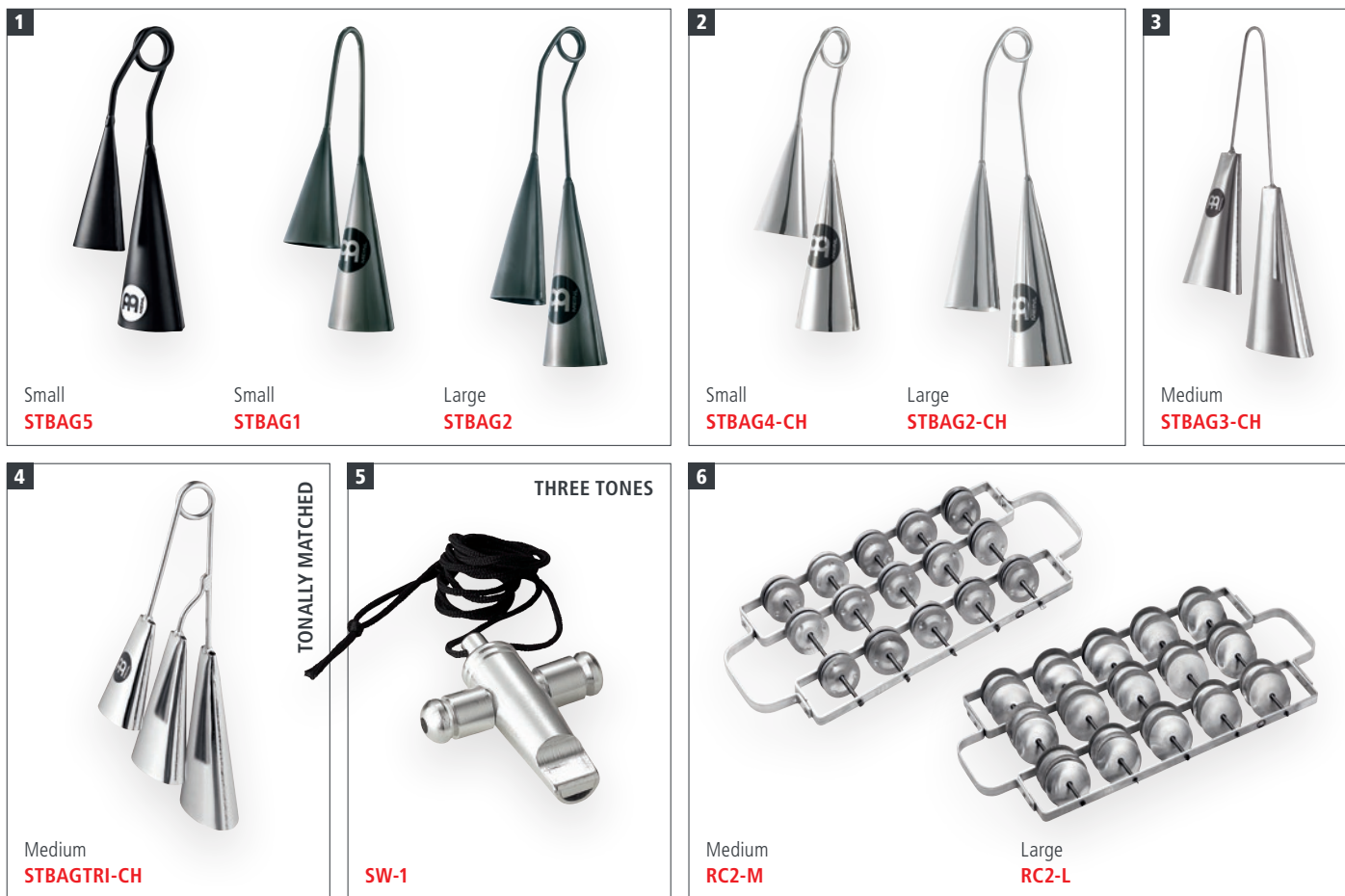

1 MODERN STYLE A-GO-GO STEEL FINISH MODELS

SIZES **STBAG1, STBAG5:** Small
STBAG2: Large
MATERIAL Special steel alloy
FEATURE Tonally matched
FINISHES **STBAG1, STBAG2:** Hand brushed steel
STBAG5: Black powder coating

2 MODERN STYLE A-GO-GO CHROME FINISH MODELS

SIZES **STBAG4:** Small; **STBAG2:** Large
MATERIAL Special steel alloy
FEATURES Flexible connection; Bright sound
FINISH High polished chrome

3 TRADITIONAL STYLE A-GO-GO BELL

SIZE Medium
MATERIAL Special steel alloy
FEATURES Traditional shape; Flexible connection
FINISH High polished chrome

4 TRIPLE A-GO-GO BELL

SIZE Medium
MATERIAL Chrome plated steel
FEATURES Traditional Shape; Three tonally matched bells in equal intervals; Spring handle enables counterpoint rhythms

5 SAMBA WHISTLE

MATERIAL Aluminum
INCLUDES Neck lanyard

6 ALUMINUM ROCARS

SIZES **RC2-M:** Medium; **RC2-L:** Large
MATERIAL Aluminum frame and jingles
FEATURES Light weight frame; Loud projection

ALUMINUM SURDOS

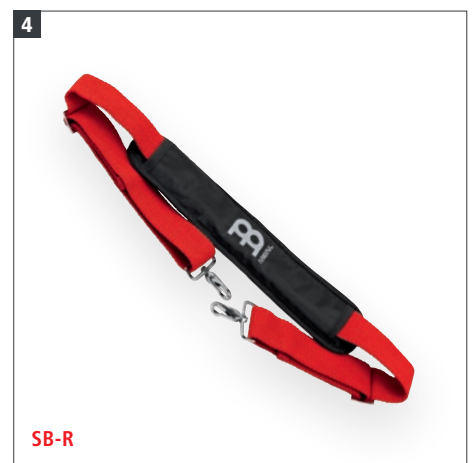

1 CLASSIC SERIES SURDOS (PATENTED)

SIZES **SUC16:** 16" diameter, 20" tall
SUC18: 18" diameter, 22" tall
SUC20: 20" diameter, 24" tall

MATERIAL Aluminum

FEATURES Countersunk bolt heads
Traditional rim
Chrome plated hardware
Traditional plain shell
8 tuning lugs (16" & 18" models)
10 tuning lugs (20" model)
Logo applied from underneath the head
(CN, TH, US patent)

INCLUDES Tuning key

2 BAHIA ALUMINUM SURDOS (PATENTED)

SIZES **SUB18:** 18" diameter, 16" tall
SUB20: 20" diameter, 16" tall
SUB22: 22" diameter, 18" tall

MATERIAL Aluminum

FEATURES Countersunk bolt heads
Chrome plated hardware
Two head options
8 tuning lugs (18" model)
10 tuning lugs (20" & 22" models)
Logo applied from underneath the head
(CN, TH, US patent)

INCLUDES Tuning key

3 TRADITIONAL ALUMINUM SURDOS (PATENTED)

SIZES **SU16:** 16" diameter, 20" tall
SU18: 18" diameter, 22" tall
SU20: 20" diameter, 24" tall
SU22: 22" diameter, 24" tall

MATERIAL Aluminum

FEATURES Countersunk bolt heads
Chrome plated hardware
Two head options
8 tuning lugs (16" & 18" models)
10 tuning lugs (20" & 22" models)
Logo applied from underneath the head
(CN, TH, US patent)
SU22-L, SU20-L, SU18-L, SU16-L:
Height adjustable legs

INCLUDES Tuning key

5

22" **HEAD-69** 20" **HEAD-68** 18" **HEAD-67** 16" **HEAD-66**

6

SHORTER SHELLS ENABLE WEARING IN LOWER POSITION

22" **SUB22AB-M** 20" **SUB20AB-M** 18" **SUB18AB-M**

7

22" **SU22AB-M** 20" **SU20AB-M** 18" **SU18AB-M** 16" **SU16AB-M**

22" **SU22-L-AB-M** 20" **SU20-L-AB-M** 18" **SU18-L-AB-M** 16" **SU16-L-AB-M**

SIX-PLY HARDWOOD SHELLS FOR A FULL AND WARM SOUND

HEIGHT ADJUSTABLE LEGS

SAMBA BEATERS (SEE PAGE 129)

SB1-2 **SB4** **SB5**

SURDO BEATER HOLDER (SEE PAGE 129)

SBH

4 SAMBA BELT
MATERIAL Cotton
FEATURES Length adjustable
 Adjustable shoulder padding
 Strong attachment hooks
COLOR **R:** Red

5 SURDO NAPA HEADS
SIZES **HEAD-66:** 16"
HEAD-67: 18"
HEAD-68: 20"
HEAD-69: 22"
MATERIALS Nylon and leather cloth
FEATURE Bonded in a hoop
COLOR Black

6 BAHIA WOOD SURDOS (PATENTED)
SIZES **SUB18:** 18" diameter, 16" tall
SUB20: 20" diameter, 16" tall
SUB22: 22" diameter, 18" tall
MATERIAL Six-ply hardwood shells
FEATURES Countersunk bolt heads
 Chrome plated hardware
 Two head options
 8 tuning lugs (18" model)
 10 tuning lugs (20" & 22" models)
 Logo applied from underneath the head (CN, TH, US patent)
INCLUDES Tuning key
COLOR **AB:** Antique Brown
FINISH Matte

7 TRADITIONAL WOOD SURDOS (PATENTED)
SIZES **SU16:** 16" diameter, 20" tall
SU18: 18" diameter, 22" tall
SU20: 20" diameter, 24" tall
SU22: 22" diameter, 24" tall
MATERIAL Six-ply hardwood shells
FEATURES Countersunk bolt heads
 Chrome plated hardware
 Two head options
 8 tuning lugs (16" & 18" models)
 10 tuning lugs (20" & 22" models)
 Logo applied from underneath the head (CN, TH, US patent)
SU22-L, SU20-L, SU18-L, SU16-L:
 Height adjustable legs
INCLUDES Tuning key
COLOR **AB:** Antique Brown
FINISH Matte

TIMBAS, TANTAM, REBOLO, REPINIQUES & CUICAS



1 TIMBAS (PATENTED)

SIZES **TIM1428:** 14" diameter, 28" tall
TIM1435: 14" diameter, 35" tall

MATERIALS Poplar Wood (*Populus*)
Replaceable synthetic head

FEATURES Lightweight shell; Chrome plated hardware; Comfortable rounded rim; Strong hook to carry it on a belt; Logo applied from underneath the head (CN, TH, US patent)

INCLUDES Tuning key

COLOR **AB-M:** Antique Brown, matte

2 TANTAM

SIZE 14" diameter, 28" tall

MATERIALS Poplar Wood (*Populus*)
Replaceable synthetic Napa head

FEATURES Lightweight shell; Chrome plated hardware; Strong hooks to carry it on a belt

INCLUDES Tuning key

COLOR **AB-M:** Antique Brown, matte

3 REBOLO

SIZE 12" diameter, 18" tall

MATERIALS Poplar Wood (*Populus*)
Replaceable synthetic Napa head

FEATURES Lightweight shell; Chrome plated hardware; Mechanical lug tuning; Strong hooks to carry it on a belt

INCLUDES Tuning key

COLOR **AB-M:** Antique Brown, matte

4 ALUMINUM REPINIQUES (PATENTED)

SIZES **RE10:** 10" diameter, 10" tall
RE12: 12" diameter, 12" tall

MATERIALS Aluminum
Replaceable synthetic heads

FEATURES Countersunk bolt heads; Chrome plated hardware; 6 tuning lugs (10" model); 8 tuning lugs (12" model); Logo applied from underneath the head (CN, TH, US patent)

INCLUDES Tuning key

5 ALUMINUM CUICAS

SIZES **QW6:** 6" diameter
QW10: 10" diameter

MATERIALS Aluminum
Hand selected goatskin heads

FEATURE **QW10:** Countersunk bolt heads

INCLUDES Tuning key

CAIXAS, COMPACT SNARE DRUMS & TAMBORIMS



SAMBA

6 PROFESSIONAL SNARE THROW-OFF MECHANISM

14" x 4"
CA14

12" x 4 1/2"
CA12

7 TRADITIONAL STYLE WITH GUITAR STRINGS

12" x 6"
CA12T

8

Maple, 10"
MPSS

9

Maple, 10"
MPJS

10 MESH HEAD FOR SUPER LOW VOLUME PRACTICE

ABS, Black
STBR06ABS-BK

11

ABS, Black
TBR06ABS-BK

ABS, Green
TBR06ABS-GR

ABS, Red
TBR06ABS-R

ABS, Yellow
TBR06ABS-Y

Aluminum
TBR06ALU

TAMBORIM STICKS
(SEE PAGE 128)

TBR5-BK **TBR5-R**

6 ALUMINUM CAIXAS (PATENTED)
SIZES CA12: 12" diameter, 4 1/2" tall
 CA14: 14" diameter, 4" tall
MATERIALS Aluminum; Replaceable synthetic heads
FEATURES Countersunk bolt heads; Steel snare wires; Professional snare throw-off mechanism; Logo applied from underneath the head (CN, TH, US patent)
INCLUDES Tuning key

7 TRADITIONAL ALUMINUM CAIXA (PATENTED)
SIZE 12" diameter, 6" tall
MATERIALS Aluminum; Replaceable synthetic heads
FEATURES Traditional style snares made from guitar strings; Extra deep body; Countersunk bolt heads; Logo applied from underneath the head (CN, TH, US patent)
INCLUDES Tuning key

8 COMPACT SIDE SNARE DRUM
SIZE 10", 3.5" deep
MATERIAL Maple
COLOR Black

9 COMPACT JINGLE SNARE DRUM
SIZE 10", 4.5" deep
MATERIALS Maple shell
 Stainless steel jingles
COLOR Black

10 SILENT TAMBORIM
SIZE 6" diameter
MATERIALS Molded ABS
 Replaceable mesh head
FEATURE Floatune Tuning System; Countersunk bolt lugs; Mesh head for super low volume practice
INCLUDES Washer as tuning key
COLOR **BK**: Black

11 FLOATUNE TAMBORIMS (PATENTED)
SIZE 6" diameter
MATERIALS Replaceable synthetic heads
ABS: ABS
ALU: Aluminum
FEATURES Floatune Tuning System; Countersunk bolt lugs; Logo applied from underneath the head (CN, TH, US patent)
INCLUDES Washer as tuning key
COLORS **BK**: Black
GR: Green
R: Red
Y: Yellow

POP OFF CONGAS

1



11 1/2" VR-POH115-SH 9 1/2" VR-POH95-SH 8" VR-POH8-SH

11 1/2" VR-POH115-NH 9 1/2" VR-POH95-NH 8" VR-POH8-NH

MAY BE PLAYED BY THEMSELVES AS A SMALL HAND DRUM



2

CAN BE TAKEN OFF THE DRUM INSTANTLY WITHOUT ANY TUNING



BOOM SERIES

Set, 3 pcs.
VR-CPOSET-SH



STACKABLE FOR EASY STORAGE AND TRANSPORTATION



SOFT SOUND SERIES

Set, 3 pcs.
VR-CPOSET-NH



1 POP OFF HEADS

SIZES VR-POH8: 8" head diameter
VR-POH95: 9 1/2" head diameter
VR-POH115: 11 1/2" head diameter

MATERIALS SH: Synthetic head
NH: Napa head

FEATURES Available as Napa style (soft sound) or standard synthetic (sharp sounds); Instantly take on or off your Meinl Pop Off Conga; May be played by themselves as a small hand drum; Nylon-loop for easy removal; Pre-tuned

2 POP OFF CONGA SETS

SIZES 8" head diameter, 21" tall
9 1/2" head diameter, 23" tall
11 1/2" head diameter, 24 1/2" tall

MATERIALS Synthetic shell
SH: Synthetic head
NH: Napa head

FEATURES Synthetic shell is perfect for outdoor playing; Non-slip rubber bottom; Great for any skill level or style; Stackable for easy storage and transportation
SH: Removable, pre-tuned synthetic head for cutting sounds with sharp attack
NH: Removable, pre-tuned Napa head creates softer, warmer sound

INCLUDES Three wooden beaters

POP OFF BASS DRUMS



POP OFF CONGAS & BASS DRUMS

1 POP OFF BASS DRUM HEADS

SIZES VR-POHBD10: 10" head diameter
 VR-POHBD12: 12" head diameter
 VR-POHBD14: 14" head diameter

MATERIALS SH: Synthetic head
 NH: Napa head

FEATURES Available as Napa style (soft sound) or standard synthetic (sharp sounds); Instantly take on or off your Meinl Pop Off Bass Drum; Reverse Dot below the head for deeper sounds; May be played by themselves as a small hand drum; Nylon-loop for easy removal; Pre-tuned

2 POP OFF BASS DRUMS SETS

SIZES 10" head diameter, 18" tall
 12" head diameter, 19 1/2" tall
 14" head diameter, 23 1/2" tall

MATERIALS Synthetic shell
 SH: Synthetic head
 NH: Napa head

FEATURES Synthetic shell is perfect for outdoor playing; Non-slip rubber bottom; Great for any skill level or style; Lower tones with great resonance; Reverse Dot below the head for deeper sounds; Stackable for easy storage and transportation
 SH: Removable, pre-tuned synthetic head for cutting sounds with sharp attack
 NH: Removable, pre-tuned Napa head creates softer, warmer sound

INCLUDES Three wooden beaters

CULTURE INSTRUMENTS

A man with a beard and a light blue patterned shirt is playing a doudou drum. He is smiling and looking towards the camera. The background is a solid blue color. The drum is a large, round, shallow drum with a patterned head and a wooden body. The man is holding the drum with both hands, and his right hand is positioned to strike the head. The lighting is bright and even, highlighting the man's features and the texture of the drum.

Cultural percussion instruments like doudous, darbukas, ibo drums, and talking drums carry rich musical traditions from around the globe. The doudou and darbuka, with their roots in Middle Eastern music, offer sharp, staccato rhythms and deep, resonant tones, perfect for intricate hand drumming patterns. Ibo drums, often used in African and Latin music, bring a unique ceramic timbre, while talking drums, known for their pitch-changing capabilities, are an integral part of West African communication and storytelling traditions. These instruments not only offer diverse sounds but also connect musicians to deep cultural histories, making them a powerful addition to any percussive setup.



8 3/4"
AEE1

8 3/4"
AEE2

8 3/4"
AEE3

9"
AEE4

9"
AEE5

NEW

DOUMBEKS



9"
AEE6



Daoud Debu is a percussionist that is well known throughout the world for his unique and fun style of playing Darbuka, he's also the drummer for DEBU band (a Sufi Music group), and the cofounder of "Serikat Darbuka Indonesia", which is now the largest Darbuka community in the world, with over 6000 members, and he is always happy to be given a chance to share his talents with anyone that wants to listen.



8 3/4", White
HEAD-136

8 3/4", Black
HEAD-137

8 3/4", Clear
HEAD-138

9", Clear
HEAD-142



8 1/2"
HE-3030

HAND HAMMERED SHELL



8 1/2"
HE-3000

LEATHERETTE COVERED SHELL



STANDARD DOUMBEK BAG
(SEE PAGE 134)

MSTDOB

1 ARTISAN EDITION EGYPT DOUMBEKS

SIZES **AEE1, AEE2, AEE3:** 8 3/4" diameter, 17" tall
AEE4, AEE5: 9" diameter, 18 3/4" tall

MATERIALS Aluminum shell; Synthetic head; Mother of pearl inlays

AEE1, AEE2, AEE4: White Pearl
AEE3, AEE5: Blue Pearl

FEATURES Authentic Egyptian mosaic inlays; Produces outstanding dums and taks (teks)

INCLUDES Tuning key

DESIGNS **AEE1:** Mosaic Royale
AEE2: Mosaic Imperial
AEE3: Mosaic Palace
AEE4: Mosaic Queen
AEE5: Mosaic Blue Lagon

2 DAOD DEBU SIGNATURE ARTISAN EDITION DOUMBEK

SIZE 9" diameter, 18 3/4" tall

MATERIALS Aluminum shell; Synthetic head; Signature mother of pearl inlays; White Pearl

FEATURES Authentic Egyptian mosaic inlays; Produces outstanding dums and taks (teks)

INCLUDES Tuning key

3 ARTISAN EDITION EGYPT DOUMBEK HEADS

SIZES **HEAD-136, HEAD-137, HEAD-138:** 8 3/4" diameter
HEAD-142: 9" diameter

MATERIAL Synthetic head

FEATURES Designed for the Meinl Artisan Edition Doumbeks

COLORS **HEAD-136:** White
HEAD-137: Black
HEAD-138, HEAD-142: Clear

4 ALUMINUM DOUMBEK, HAND HAMMERED

SIZE 8 1/2" diameter, 17 1/8" tall

MATERIALS Aluminum shell; Synthetic head

INCLUDES Tuning key

5 ALUMINUM DOUMBEK

SIZE 8 1/2" diameter, 17 1/8" tall

MATERIALS Aluminum shell (leatherette covered); Synthetic head

INCLUDES Tuning key

COLOR Black

DARBUKAS

1



8"
HE-114



7 1/4"
HE-113



PROFESSIONAL DARBUKA BAG
(SEE PAGE 134)



MDAB

2



8"
HE-104



7 1/4"
HE-103



6 1/2"
HE-102



5 7/8"
HE-101



5 1/3"
HE-100



1 ALUMINUM DARBUKAS, HAND HAMMERED

SIZES **HE-113:** 7 1/4" diameter, 13 1/3" tall
HE-114: 8" diameter, 14 1/2" tall

MATERIALS Aluminum shell; Synthetic head

FEATURE Hand hammered shell

INCLUDES Tuning key

2 ALUMINUM DARBUKAS, PLAIN

SIZES **HE-100:** 5 1/3" diameter, 9 1/4" tall

HE-101: 5 7/8" diameter, 11" tall

HE-102: 6 1/2" diameter, 12 3/4" tall

HE-103: 7 1/4" diameter, 13 1/3" tall

HE-104: 8" diameter, 14 1/2" tall

MATERIALS Aluminum shell; Synthetic head

INCLUDES Tuning key



BE1R



8 1/2" Bayan & 5 1/2" Dayan
TABLA



MADE BY MASTER CRAFTSMEN IN INDIA

9" Bayan & 5 1/2" Dayan
PRO-TABLA



TRADITIONAL TTR-RIMS

6 3/4" & 12" Iya
BA3BK

5 3/4" & 8 3/4" Itotele
BA2BK

5 1/4" & 8" Okonkolo
BA1BK

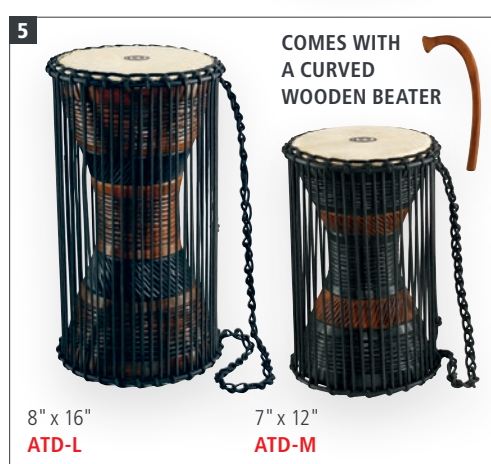

COMES WITH A CURVED WOODEN BEATER

8" x 16"
ATD-L

7" x 12"
ATD-M



White
ID10WH



RAWHIDE PLAYING SURFACE

ID3GO

EXTRA FIBERGLASS PLAYING SURFACE

ID4BKO



THE FIBERGLASS LIQUID IBO DRUM IS FILLED WITH WATER

ID9BK/WH

1 BERIMBAU

MATERIAL Premium fiberglass
INCLUDES Small Caxixi; Metal plate; Wooden stick; Carrying bag
COLOR **R**: Red

2 TABLA SET

SIZES 5 1/2" Dayan & 8 1/2" Bayan
MATERIALS Chrome plated copper with goatskin head; Mahogany with goatskin head
FEATURE Nylon straps for longer durability
INCLUDES Padded support rings; Tuning hammer

3 ARTISAN EDITION TABLA SET

SIZES 5 1/2" Dayan & 9" Bayan
MATERIALS Copper with goatskin head; Mahogany with goatskin head
FEATURES Traditional tuning system; Rawhide thongs
INCLUDES Tuning hammer and wooden tuning dowel; Ring pads; Protective head covers

4 BATAS

SIZES **BA1**: 5 1/4" & 8" Okonkolo
BA2: 5 3/4" & 8 3/4" Itotele
BA3: 6 3/4" & 12" Iya
MATERIALS Premium fiberglass
Hand selected buffalo heads
INCLUDES Nylon strap; Tuning key

5 AFRICAN WOOD TALKING DRUMS

SIZES **M**: 7" diameter, 12" tall
L: 8" diameter, 16" tall
PP ROPES **M**: 3 mm thickness, 23 runners
L: 3 mm thickness, 28 runners
MATERIALS Mahogany Wood (*Swietenia macrophylla*)
Hand selected goatskin heads
INCLUDES Curved wooden beater

6 QUINTO IBO DRUM

SIZE Small
MATERIAL Ceramic

FEATURE Built-in microphone hole
COLOR **WH**: White

7 FIBERGLASS TRI SOUND IBO DRUMS

SIZE Large
MATERIAL Premium fiberglass
FEATURES Built-in microphone hole
ID3GO: Rawhide playing surface
ID4BKO: Extra fiberglass playing surface
INCLUDES Foam padded base
COLOR **BKO**: Black Ornament
GO: Gold Ornament

8 FIBERGLASS LIQUID IBO DRUM

SIZE Large
MATERIAL Premium fiberglass
FEATURES Special bottom, filled with water; Built-in microphone hole
INCLUDES Foam padded base
COLOR **BK/WH**: Black/White

HARD WARE



Our percussion hardware collection offers a wide range of sturdy stands, clamps, and accessories designed for durability and performance. Built to withstand the rigors of live shows and studio sessions, these pieces provide rock-solid support for your instruments, ensuring stability and precision. Whether you need adjustable conga stands, reliable clamps for your tambourines or shakers, or versatile mounts for your cymbals and drums, our hardware is crafted with high-quality materials to meet the demands of professional percussionists. Experience the confidence of using robust, well-engineered accessories that keep your setup secure and your focus on the music.



STANDS

1



Black powder coated

Black powder coated

For Marathon® Classic Series
For Marathon® Designer Series
For Luis Conte Artist Series

ST-MCC11BK: 11"
ST-MCC1134BK: 11 3/4"
ST-MCC1212BK: 12 1/2"



Chrome plated

Gold tone

Chrome plated

For Marathon® Exclusive Series

ST-MEC11CH: 11"
ST-MEC1134CH: 11 3/4"
ST-MEC1212CH: 12 1/2"

For Professional Series
For Fibercraft Series

ST-MP11CH: 11"
ST-MP1134CH: 11 3/4"
ST-MP1212CH: 12 1/2"

For Floatune Series

ST-FL10CH: 10"
ST-FL11CH: 11"
ST-FL12CH: 12"

ST-FL13CH: 13"

For Woodcraft Series

ST-WC11CH: 11"
ST-WC1134CH: 11 3/4"
ST-WC1212CH: 12 1/2"

Gold tone

For Marathon® Exclusive Series

ST-MEC11G: 11"
ST-MEC1134G: 11 3/4"
ST-MEC1212G: 12 1/2"

For Mongo Santamaria Artist Series

ST-MSA11G: 11"
ST-MSA1134G: 11 3/4"
ST-MSA1212G: 12 1/2"

**QUICK AND EASY HEIGHT
ADJUSTABILITY (DE PATENT)**

2

EASY HEIGHT EXTENSION

Black powder coated
ST-HEBK

Chrome plated
ST-HECH

Gold tone
ST-HEG



3



MIN. 43"
MAX. 52 3/4"

For Headliner® congas
HDSTAND

For MCC congas
TMDS

4

**THE LIGHTWEIGHT STAND
CAN BE FOLDED TO A
COMPACT UNIT WHICH
REQUIRES LITTLE SPACE**



Chrome plated
TMC-CH

COMPATIBLE FOR ALL SIZES!

5



Chrome plated
TMPDS

1 STEELY II CONGA STANDS (PATENTED)

MATERIAL Steel

FEATURES Metal spike attachment on each leg; L-shaped legs (DE, TH, US patent); U-shaped notch for quick set up and breakdown (US patent); Ergonomic arched rubber bracing for more stability (CN, DE, TH, US patent); Notches for quick height adjustability (DE patent)

INCLUDES Hex key

2 STEELY II CONGA STAND HEIGHT EXPANDER SETS (DE PATENT)

MATERIAL Steel

FEATURE Easy and effective height extension

INCLUDES Mounting screws; Hex key

FINISHES **BK:** Black powder coated
CH: Chrome plated
G: Gold tone

3 CONGA DOUBLE STANDS

MATERIAL Steel

FEATURES Height adjustable; Double braced tripod legs

INCLUDES Hex key; Memory locks; Brackets; Set of screws, nuts, and washers; Mounting instructions

4 PROFESSIONAL CONGA STAND

MATERIAL Chrome plated steel

FEATURES Unique design (DE patent); Rubber padded crossbeams; Fully height adjustable; Folds up to a compact unit

INCLUDES Hex key; Memory locks

5 PROFESSIONAL CONGA DOUBLE STAND WITH WHEELS

MATERIAL Chrome plated steel

FEATURES

Height adjustable; Heavy construction; Double braced tripod legs; Lockable high-quality wheels; Padded separators for adjustable angle; Mounting instructions

INCLUDES

Two mounting brackets

6 PROFESSIONAL CONGA STAND WITH WHEELS

MATERIAL Chrome plated steel

FEATURES Adjustable padded stops fit any conga size; Height adjustable legs; Lockable wheels

7 CONGA SOUND PLATE

SIZE 13 1/4"

MATERIAL Siam Oak (*Hevea brasiliensis* Muell.-Arg.)

FEATURE Provides a hard sound reflective surface under your conga

6 **STURDY LOCKABLE WHEELS MAKE IT EASY TO MOVE THE STAND INTO POSITION**

Chrome plated
TMPC

8

Chrome plated
MCH-CH

Gold tone
MCH-G

FOR ANY CONGA

7 **FITS UNDER ANY CONGA**

CSP

9

For HDSTAND and TMDS
THBM

EASY MOUNTABLE

10

MIN. 34 1/2" MAX. 50"

Black powder coated
THBS-BK

Chrome plated
THBS

AN INNOVATIVE BRACKET DESIGN ENABLES QUICK SET UP (PATENTED)

11 **PADDED T-SHAPED TUBE FOR MORE STABILITY**

MIN. 31 1/2" MAX. 52 3/4"

Chrome plated
TMB

12 **A STABLE METAL CLAMP HOLDS THE ENTIRE UNIT IN PLACE**

MIN. 12 1/4" MAX. 20"

Chrome plated
TMB-S

LOW HEIGHT FOR SEATED PLAYERS

13 **PERFECT HEIGHT FOR CAJON PLAYERS**

MIN. 22 3/4" MAX. 29 1/2"

Black powder coated
THBS-S-BK

14 **DIFFERENT RODS FOR ALL NEEDS**

MIN. 31 1/2" MAX. 52 1/2"

Chrome plated
TMPS

8 CONGA HANDLES
MATERIAL Steel
FEATURES Simple and safe add-on to help transport congas; Easily mountable with instructional guide; Fits any common conga; Leaves sound unaffected
INCLUDES Mounting screws and washers; Mounting instructions
FINISHES **CH:** Chrome plated
G: Gold tone

9 BONGO MOUNT
MATERIAL Chrome plated steel
FEATURES Easy mountable on our conga double stands HDSTAND and TMDS; Holds your bongo in place; Adjustable angle

10 HEADLINER® SERIES BONGO STANDS (CN, DE, US PATENT)
MATERIAL Steel
FEATURES Quick set up; Easy handling; Reliable placement; Double braced tripod stand; Fits all common bongos
INCLUDES Wrench
FINISHES **THBS:** Chrome plated
THBS-BK: Black powder coated

11 PROFESSIONAL BONGO STAND
MATERIAL Chrome plated steel
FEATURES Padded T-shaped tube; Fully height and angle adjustable; Double braced tripod legs; Fits all common bongos
INCLUDES Hex key; Memory locks

12 PROFESSIONAL BONGO STAND FOR SEATED PLAYERS
MATERIAL Chrome plated steel
FEATURES Seated playing position possible; Padded T-shaped tube; Fully height and angle adjustable; Double braced tripod legs; Fits all common bongos
INCLUDES Hex key; Memory lock

13 CAJON HEIGHT BONGO STAND
MATERIAL Black powder coated steel
FEATURES Quick set up; Easy handling; Perfect height for cajon players; Fits all common bongos

14 PERCUSSION STAND
MATERIAL Chrome plated steel
FEATURES Height adjustable; Double braced tripod legs
INCLUDES Hex key; Memory locks; 2 straight rods; 2 angled rods; 2 Z-shaped rods

STANDS

1 COLLAPSIBLE DESIGN



Black powder coated
STDJST-BK

2



QUICK AND EASY HEIGHT ADJUSTABILITY (DE PATENT)



Chrome plated
ST-DJEMBE

3 LENGTH ADJUSTABLE FOR VARIOUS DJEMBE SIZES



MIN. 23 1/2"
MAX. 37 3/4"



Chrome plated
TMD

4 FITS ALL CAJON SIZES



MIN. 26"
MAX. 40 1/2"

Black powder coated
TMCAJ

5 NEW



TMCAJ-S

6



CMS

CAJON DRUM SET STANDS (SEE PAGE 59)



CJS CCS CAS

7



MIN. 22"
MAX. 37"

Black powder coated
CPTS

1 TRAVEL DJEMBE STAND

MATERIAL Black powder coated steel
FEATURES Collapsible design; Lightweight construction

2 STEELY II DJEMBE STAND (PATENTED)

MATERIAL Chrome plated steel
FEATURES Metal spike attached to each leg; L-shaped legs (DE, TH, US patent); U-shaped notch for quick set up and breakdown (US patent); Ergonomic arched rubber bracing for more stability (CN, DE, US patent); Notches for quick height adjustability (DE patent); Adapts to different djembe sizes

INCLUDES Hex key, 3 spacers

3 PROFESSIONAL DJEMBE STAND

MATERIAL Chrome plated steel
FEATURES Rubber padded hooks; Fully height and angle adjustable; Double braced tripod legs

INCLUDES Hex key; Memory lock

4 PROFESSIONAL CAJON STAND

MATERIAL Steel
FEATURES Quick set up; Fully height and angle adjustable; Double braced tripod stand; Fits all cajon sizes

5 PROFESSIONAL LOW CAJON STAND

MATERIALS Chrome plated steel / Black powder coated steel
FEATURES Upright posture while playing; Perfect for traditional seated cajon performance; Sturdy, low-profile design keeps your cajon secure

6 CAJON MICROPHONE STAND

MATERIAL Black powder coated aluminum
FEATURES Round base for compact setup; Solid construction; Height adjustable

7 CAJON PICKUP TAPS STAND

MATERIAL Black powder coated aluminum
FEATURES Designed to mount the Meinl Compact Percussion Pad; Low-key stage footprint; L-Shaped 3/8" rod; Foldable legs, height adjustable

8 LOW HAT

MATERIAL Chrome plated steel
FEATURES Special low height; Made just for cajon players

8 SPECIAL LOW HEIGHT

MIN. 29 1/2"
MAX. 38"

Chrome plated
MLH

9

MIN. 34"
MAX. 57"

Chrome plated
TMT

10

MIN. 34"
MAX. 57"

Chrome plated
TMPT

11 THREE-ARM BASKET HOLDS THE HAND-BALE SECURELY

Chrome plated
TMTS

12

MIN. 31 3/4"
MAX. 50 3/4"

Chrome plated
TMID

13

Black powder coated
DDG-STAND

14

Black powder coated
TMDDGS

15

Chrome plated
TMDDG

16

MIN. 30 3/4"
MAX. 67"

Chrome plated
TMCH

9 TIMBALE STAND
MATERIAL Chrome plated steel
FEATURES Double braced tripod base; Height and angle adjustable; Standard mounting rod for auxiliary percussion
INCLUDES Accessory pouch; L-shaped tuning key; Tune Up Oil

10 PROFESSIONAL TIMBALE STAND
MATERIAL Chrome plated steel
FEATURES Heavy-duty double braced tripod base; Height and angle adjustable; Standard mounting rod for auxiliary percussion
INCLUDES Accessory pouch; Tuning key; Tune Up Oil

11 HAND-BALE STAND
MATERIAL Chrome plated steel
FEATURES Quick set up; Rubber-tipped three arm basket; Easy handling; Double braced tripod stand

12 PROFESSIONAL DOUMBЕК/IBO STAND
MATERIAL Chrome plated steel
FEATURES Foam padded ring; Fully height and angle adjustable; Double braced tripod legs
INCLUDES Hex key; Memory lock

13 DIDGERIDOO STAND
MATERIAL Black powder coated aluminum
FEATURES Steady support for your didgeridoo; Stable tripod base; Soft padding; Rubber yoke for added protection
FINISH Black

14 PROFESSIONAL DIDGERIDOO STAND
MATERIAL Black powder coated aluminum
FEATURES Dual leg base and strong aluminum construction; Protective rubber yoke and soft padding; Height and angle adjustable
FINISH Black

15 PRO DIDGERIDOO STAND
MATERIAL Chrome plated steel
FEATURES Play your didgeridoo in a seated or standing position; Accommodates most didgeridoo sizes and shapes; Padded rest with adjustable strap

16 CHIMES STAND
MATERIAL Chrome plated steel
FEATURES Full angle and height adjustability; Secure angle clamps; Telescoping stem

TABLES

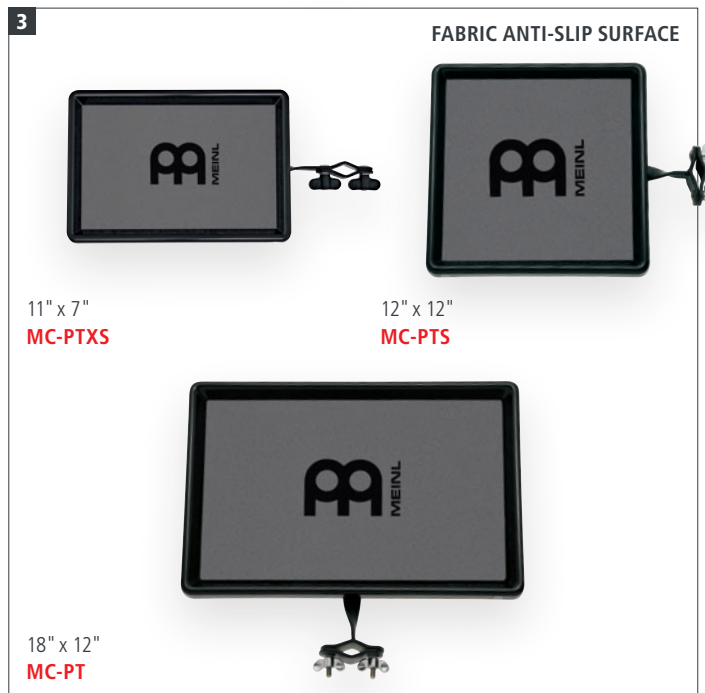

1 LAPTOP TABLE STAND

- SIZE** 20" x 12 1/2"
- MATERIAL** Perforated metal plate
- FEATURES** Holds laptops up to 17"
Stoppers, hook and loop fastener to secure the laptop
Holder for headphones
Cord strain relief

2 LIGHT LAPTOP TABLE STAND

- SIZE** 14 1/2" x 10 3/4"
- MATERIAL** Aluminum
- FEATURES** Holds laptops up to 16"
Fabric anti-slip surface
Height adjustable
Foldable legs

3 PERCUSSION TABLES

- SIZES** **MC-PT:** 18" x 12"
MC-PTS: 12" x 12"
MC-PTXS: 11" x 7"
- MATERIALS** **MC-PT, MC-PTS:** Premium fiberglass
MC-PTXS: Synthetic
- FEATURES** Fabric anti-slip surface
Adjustable angle
Strong mounting clamp

4 HEIGHT ADJUSTABILITY AT ALL POINTS

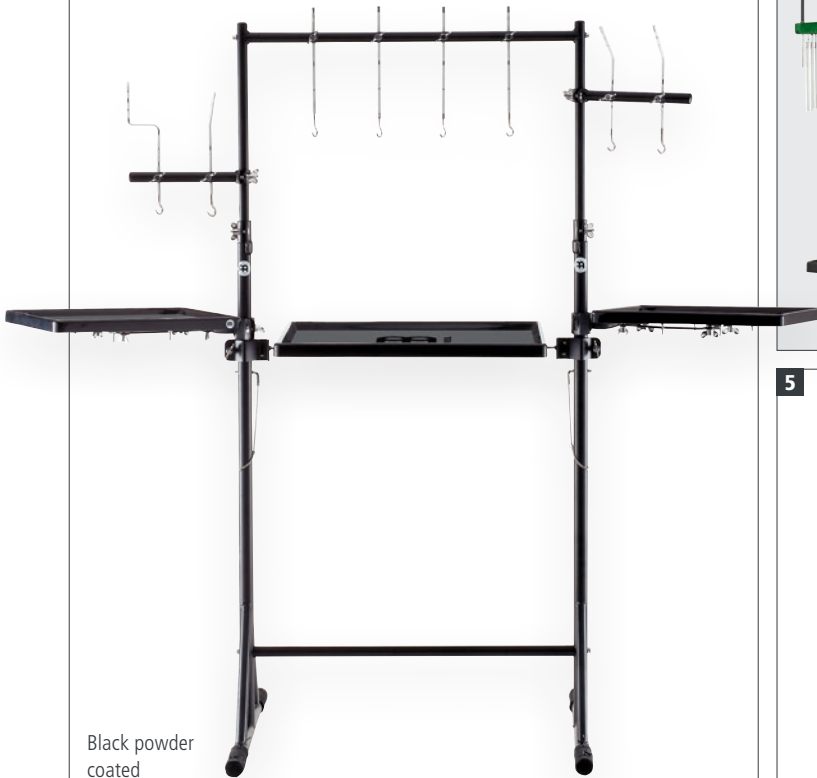

Black powder coated
TMPWS



5 ALL MEINL TRIPOD STANDS ARE EQUIPPED WITH MEMORY AND QUICK LOCKS



MIN. 30"
MAX. 46 3/4"

16" x 22"
TMPTS







4 PERCUSSION WORKSTATION

- MATERIAL** Black powder coated steel
- FEATURES** Fully height adjustable
Angle adjustable top bar
Heavy-duty construction
Infinitely expandable
Fabric anti-slip surfaces
Color doesn't interfere with stage lighting
- INCLUDES** 1 x Padded fiberglass percussion table, 22" x 24"
2 x Padded fiberglass percussion tables, 18" x 12" (attachable)
1 x Vertical bar, 30"
2 x Vertical bars, 15" (attachable)
4 x Straight rods with hook
3 x Angled rods with hook
1 x Z-shaped rod with hook

5 PERCUSSION TABLE STAND

- SIZE** 16" x 22"
- MATERIALS** Table: Premium fiberglass
Stand: Chrome plated steel
- FEATURES** Fabric anti-slip surface
Fully height adjustable
Double braced tripod legs
- INCLUDES** Hex key
Memory lock

HARDWARE

<p>1 HOLDS TAMBOURINES AND SHAKERS</p>  <p>Mini Percussion Rack MC-SHTA</p>	<p>2 PADDED SURFACE</p>  <p>Tambourine Holder MC-TH</p>	<p>3</p>  <p>MIN. 1" MAX. 6"</p> <p>Shaker Holder MC-SH</p>	
<p>4</p>  <p>MIN. 2 1/2" MAX. 3 3/4"</p> <p>Güiro Holder MC-GU</p>	<p>5</p>  <p>Wood Block Holder MWBH1</p>	<p>6</p>  <p>Standard Frame Drum Holder MC-STFDH</p>	<p>7</p>  <p>Triangle Holder MC-TRI</p>
<p>8</p>  <p>Triangle Clamp CLAMP-TRI</p>	<p>9 FOR TURBO CABASA, MEDIUM</p>  <p>Cabasa Holder MC-CA</p>	<p>10</p>  <p>Frame Drum Holder MC-FDH</p>	
<p>11</p>  <p>Chimes Holders MC-CH MC-CHL</p>	<p>12</p>  <p>Drumstick Holders MC-DSH</p>	<p>13</p>  <p>Bass Drum Cowbell Holders MC-STBD MC-BD</p>	

1 MINI PERCUSSION RACK

MATERIALS Black powder coated steel; Foam rubber
FEATURE Holds tambourines and shakers
COLOR Black

2 TAMBOURINE HOLDER

MATERIAL Chrome plated steel
FEATURES Rubber pads; Padded surface

3 SHAKER HOLDER

MATERIAL Chrome plated steel
FEATURES Rubber pads; Length adjustable

4 GÜIRO HOLDER

MATERIAL Chrome plated steel
FEATURE Rubber pads

5 WOOD BLOCK HOLDER

MATERIAL Chrome plated steel

6 STANDARD FRAME DRUM HOLDER

MATERIAL Chrome plated steel
FEATURE Perfect for frame drums or traditional wood tambourines

7 TRIANGLE HOLDER

MATERIAL Chrome plated steel
FEATURES Knurled surface; Nylon cord

8 TRIANGLE CLAMP

MATERIAL Chrome plated steel
FEATURES Holds any triangle in place; Easy mountable

9 CABASA HOLDER

MATERIAL Chrome plated steel
FEATURES Strong mounting clamp; Padded surface

10 FRAME DRUM HOLDER

MATERIALS Chrome plated steel; Anodized aluminum
FEATURE Fully adjustable for any frame drum size

11 CHIMES HOLDERS

SIZES **MC-CH**: Regular
MC-CHL: Large
MATERIAL Chrome plated steel
FEATURES Knurled surface; Foam washer

12 DRUMSTICK HOLDER

MATERIALS Chrome plated steel; Black textile pouch
FEATURE Strong mounting clamp
FINISH Meil

13 BASS DRUM COWBELL HOLDERS

MATERIALS **MC-BD**: Chrome plated steel
MC-STBD: Black powder coated steel
FEATURES Rubber pads
MC-BD: Fully adjustable
INCLUDES **MC-BD**: L-shaped rod

14

Multi Clamp for Cymbal Stands
PMC-1

15

Pedal Mount
PM-1

16

Pedal Mount for Cymbals
PM-2

17

Cymbal Stackers
MC-CYS **MC-CYS8** **MC-CYS8-S**

18

MC-CY1
MC-CY2
MC-CY

Cymbal Holder Attachments

20

Cymbal Attachment
MCA

19

X-Hat Cymbal Stand Adapter
MXHA

22

X-Hat Auxiliary Hihat Arm
MXH

21

Double Extension Arm
MDEA

14 MULTI CLAMP FOR CYMBAL STANDS
MATERIAL Chrome plated steel
FEATURES Double-sided clamp; Attach a cymbal or tom arm to any stand; Universal for all standard drum hardware; Metal body with durable synthetic thumb screws

15 PEDAL MOUNT
MATERIAL Black powder coated steel
FEATURES Height adjustable legs; Metal spikes; Fits on all common bass drum pedals and firmly holds cowbells, blocks, or tambourines
INCLUDES 2 differently sized L-rods

16 PEDAL MOUNT FOR CYMBALS
MATERIAL Black powder coated steel
FEATURES For foot activated cymbal crashes; Holds cymbals ranging from 16" to 22"
INCLUDES Cymbal arm

17 CYMBAL STACKERS
SIZES **MC-CYS:** Ø 6 mm, long
MC-CYS8: Ø 8 mm, long
MC-CYS8-S: Ø 8 mm, short
MATERIAL Chrome plated steel
FEATURE Felt washers

18 CYMBAL HOLDER ATTACHMENTS
MATERIAL Chrome plated steel
FEATURES Knurled surface; Felt washers; For splashes or small crashes; Easy placement on a drumkit, cajon set or percussion rig
MC-CY: Z-shaped 3/8" rod
MC-CY1: S-shaped 3/8" rod
MC-CY2: Z-shaped 3/8" rod with extra-long knurled end

19 X-HAT CYMBAL STAND ADAPTER
MATERIAL Chrome plated steel
FEATURES Turn any cymbal stand into an X-Hat stand; Fits 8 mm threaded cymbal stand posts; Use with any size hihat or stack

20 CYMBAL ATTACHMENT
MATERIAL Chrome plated steel
FEATURES Multi-clamp; Cymbal boom arm

21 DOUBLE EXTENSION ARM
MATERIAL Chrome plated steel
FEATURES Two points of 360-degree adjustability; Heavy-duty chrome plated steel; Length adjustable

22 X-HAT AUXILIARY HIHAT ARM
MATERIAL Chrome plated steel
FEATURE Easy to attach and position at any height or angle

HARDWARE



Mic. Cymbal Clamp Set
MPMCS



Mic. Drumset Clamp Set
MPMDS

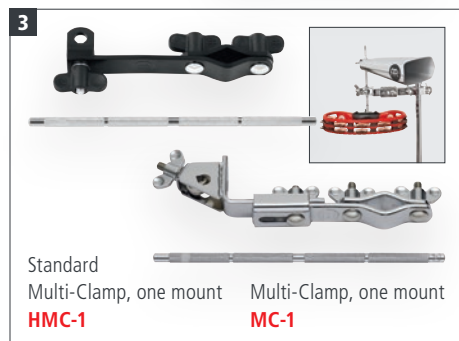

Standard Multi-Clamp, one mount
HMC-1 Multi-Clamp, one mount
MC-1

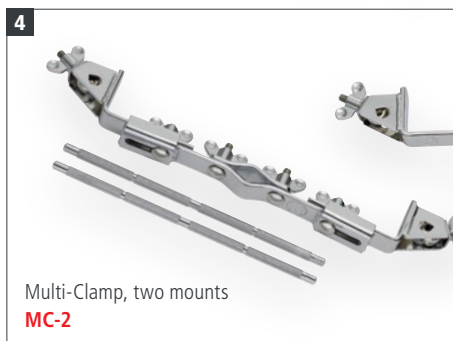

Multi-Clamp, two mounts
MC-2

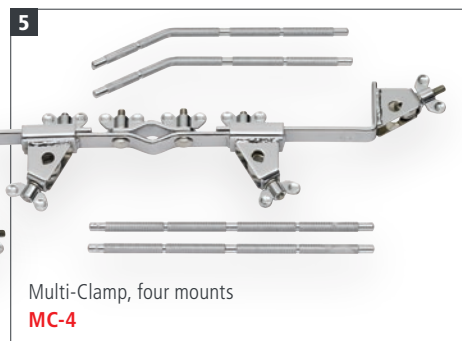

Multi-Clamp, four mounts
MC-4

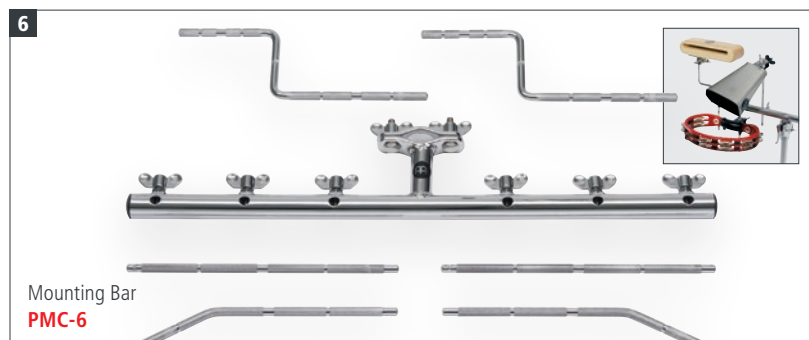

Mounting Bar
PMC-6

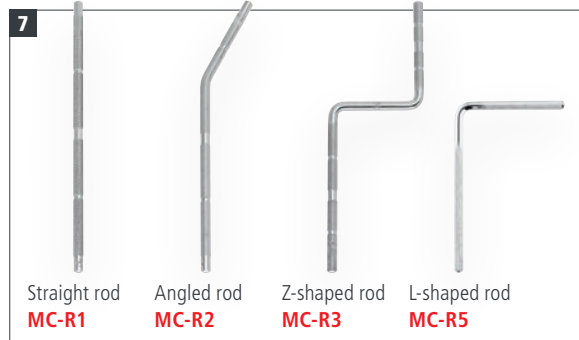

Straight rod
MC-R1 Angled rod
MC-R2 Z-shaped rod
MC-R3 L-shaped rod
MC-R5

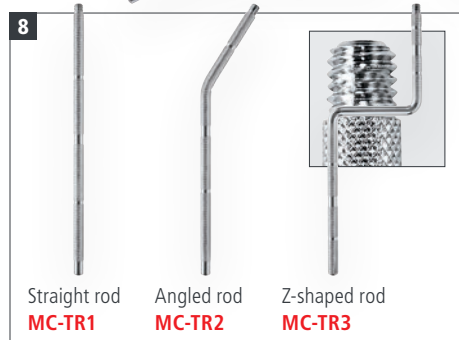

Straight rod
MC-TR1 Angled rod
MC-TR2 Z-shaped rod
MC-TR3



Short rod
MC-MR1-S Straight rod
MC-MR1 Angled rod
MC-MR2 Z-shaped rod
MC-MR3

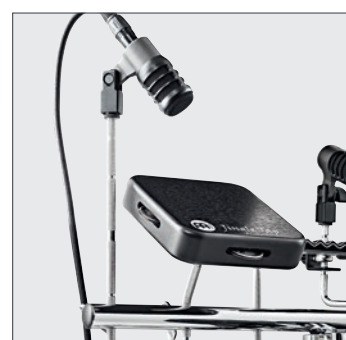

1 MICROPHONE CYMBAL CLAMP SET

CONTAINS 3 x Standard Multi-Clamp (HMC-1); 3 x Short Rod With Threaded Microphone Connector (MC-MR1-S); 1 x Microphone Rod Counter Nuts (MRCN5)

2 MICROPHONE DRUMSET CLAMP SET

CONTAINS 1 x Bass Drum Microphone Clamp (MC-MRBD); 4 x Rimclamp (RIMCLAMP-2); 4 x Short Rod With Threaded Microphone Connector (MC-MR1-S); 1 x Microphone Rod Counter Nuts (MRCN5)

3 MULTI-CLAMPS, ONE MOUNT

MATERIALS **HMC-1:** Black powder coated steel
MC-1: Chrome plated steel
FEATURES Strong mounting clamp
MC-1: Length adjustable
INCLUDES Straight rod

4 MULTI-CLAMP, TWO MOUNTS

MATERIAL Chrome plated steel
FEATURES Length adjustable; Strong mounting clamp
INCLUDES 2 straight rods

5 MULTI-CLAMP, FOUR MOUNTS

MATERIAL Chrome plated steel
FEATURES Length adjustable; Strong mounting clamp
INCLUDES 2 straight and 2 angled rods

6 MOUNTING BAR

MATERIAL Chrome plated steel
INCLUDES 2 straight, 2 angled and 2 z-shaped rods

7 RODS

MATERIAL Chrome plated steel
FEATURES Knurled surface; Available as a straight, angled, z-shaped, or l-shaped rod

8 THREADED PERCUSSION RODS

MATERIAL Chrome plated steel
FEATURE Threaded tip to mount any standard 3/8" threaded percussion instrument

9 RODS WITH THREADED MICROPHONE CONNECTOR

MATERIAL Chrome plated steel
FEATURES 3/8" diameter rod with threaded end; Designed to attach microphones; Use with the Meinl Rim Clamp; Available as a short, straight, angled, or z-shaped rod
INCLUDES Microphone screw adapter

10 BASS DRUM MICROPHONE CLAMP

MATERIAL Chrome plated steel
FEATURE U-shape 3/8" diameter rod with threaded end to attach a microphone



10
Bass Drum
Microphone Clamp
MC-MRBD



11
Set, 5 pcs.
Microphone Rod Counter Nuts
MRCN5



12
Flexible Microphone Gooseneck
FMG



13
Microphone
Cajon Clamp
MPMCC



14
Microphone
Adapter
TMMA



15
Clamp
CLAMP



16
Rim Clamps
RIMCLAMP-2

RIMCLAMP



RIMCLAMP-M

PERFECT MIC PLACEMENT ON ANY COMMON DRUM RIM



17
Professional Multi-Clamps
TMPMC

TMPMC-R



TMPMC-G

STRONG CLAMP SECURES TO ANY DRUM RIM

11 MICROPHONE ROD COUNTER NUTS

MATERIAL Black powder coated steel
FEATURES Set of 5 counter nuts; Securely lock your microphone attachments

12 FLEXIBLE MICROPHONE GOOSENECK

SIZE 12.8" (32.5 cm)
MATERIAL Metal
FEATURES Optimal microphone placement; No additional stand required; Fits in the Meinl Rim Clamp; 3/8" and 5/8" threads

13 MICROPHONE CAJON CLAMP

MATERIAL Steel
FEATURE Foam padding ensures quiet recording

14 MICROPHONE ADAPTER

MATERIAL Chrome plated steel
FEATURES Turns your cymbal stand into a microphone stand; 8 mm threaded attachment

INCLUDES 5/8" male to 3/8" mic screw adapter

15 CLAMP

MATERIAL Chrome plated steel
FEATURE Compact and solid design

16 RIM CLAMPS

MATERIALS Black powder coated steel
RIMCLAMP: Chrome plated steel (L-shaped rod)
RIMCLAMP-M: Metal (Gooseneck)
FEATURES Fully height and angle adjustable; Fits to any common drum rim
RIMCLAMP, RIMCLAMP-2: Holds percussion accessories right where you need them
RIMCLAMP-M: Works with all 3/8" or 5/8" mic clips (Mic clip not included)

INCLUDES **RIMCLAMP:** L-shaped rod
RIMCLAMP-M: Flexible Microphone Gooseneck

17 PROFESSIONAL MULTI-CLAMPS

MATERIALS Black powder coated die cast steel
TMPMC-G: Metal (Gooseneck)
TMPMC-R: Chrome plated steel (Z-shaped rod)
FEATURES 360-degree adjustable 3/8" rod eye bolt mount
TMPMC: Strong clamp secures to any drum set or percussion rim
TMPMC-G: Removable flexible microphone gooseneck; Strong clamp secures to any drum set or percussion rim
TMPMC-R: Removable Z-shaped 3/8" rod to mount percussion instruments

STICKS, BEATERS, BRUSHES, MALLETS & SCRAPERS

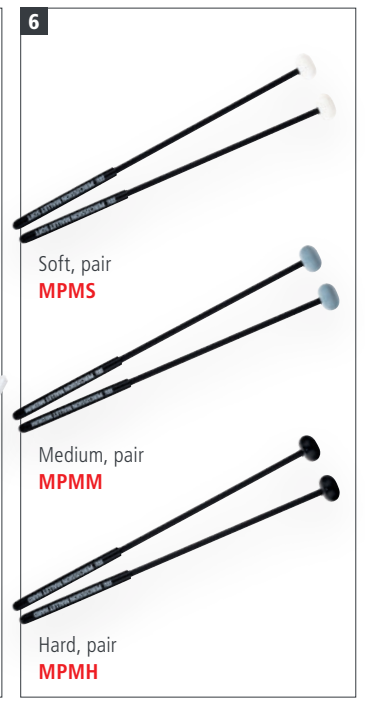
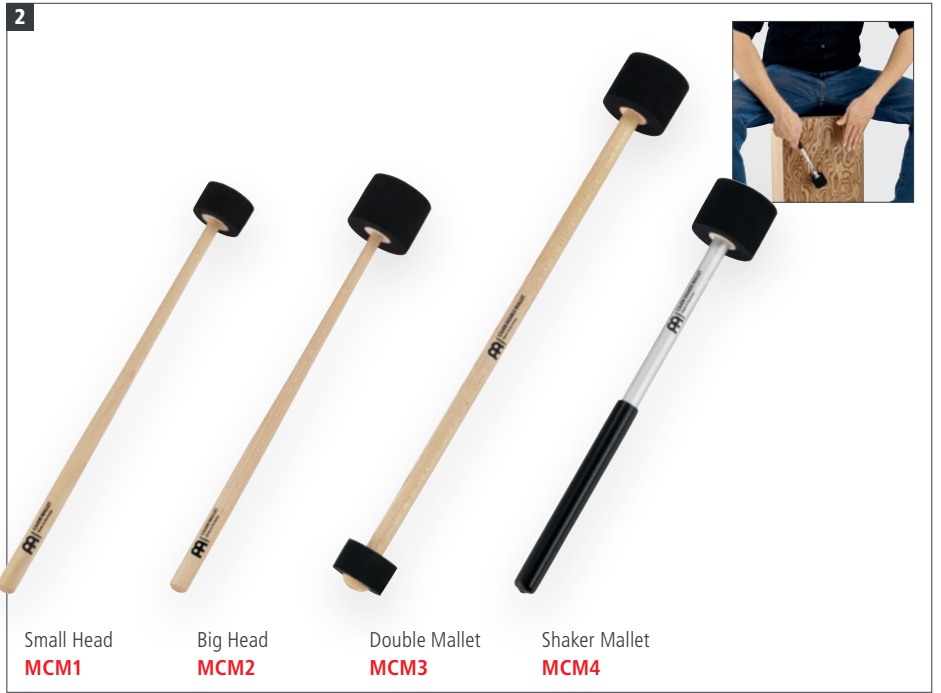

1 BASS BEAT CAJON BRUSH

SIZE 13" long
MATERIALS Polymer bristles
Foam rubber
FEATURES Straight polymer bristles for ultra-smooth precision; Soft foam rubber for full-bodied low notes; Two adjustable control rings; Flexible handle

2 CAJON Mallet COLLECTION

SIZES **MCM1, MCM4:** 11 3/4" long
MCM2: 12 1/4" long
MCM3: 15 1/2" long
MATERIALS Foam rubber
MCM1, MCM2, MCM3: Hard maple
MCM4: Aluminum

FEATURES

Made in Germany
MCM1: Made out of the finest hand-selected maple; Small foam rubber head; Designed for softer playing
MCM2: Made out of the finest hand-selected maple; Extra thick foam rubber head
MCM3: Made out of the finest hand-selected maple; Foam rubber padding; Two different ends for contrasting sounds
MCM4: Integrated shaker effect in handle; Soft foam rubber head; Lightweight aluminum handle

3 TAMBORIM STICKS

MATERIAL Synthetic
COLORS **BK:** Black
R: Red

4 BODHRAN TIPPLERS

MATERIAL Ash Wood
COLOR Antique Brown

5 SAMBA STICKS

SIZES **SST1-S:** Stick, short version
SST1-R: Stick, medium version
SST1-L: Stick, long version
SST3-S: Triple stick, short version
SST3: Triple stick
MATERIAL Synthetic

6 MOLDED ABS PERCUSSION MALLETS

SIZE 12 1/4" long
MATERIAL Durable molded ABS
FEATURES Easy to play across many different percussion instrument types
MPMS: Soft
MPMM: Medium
MPMH: Hard

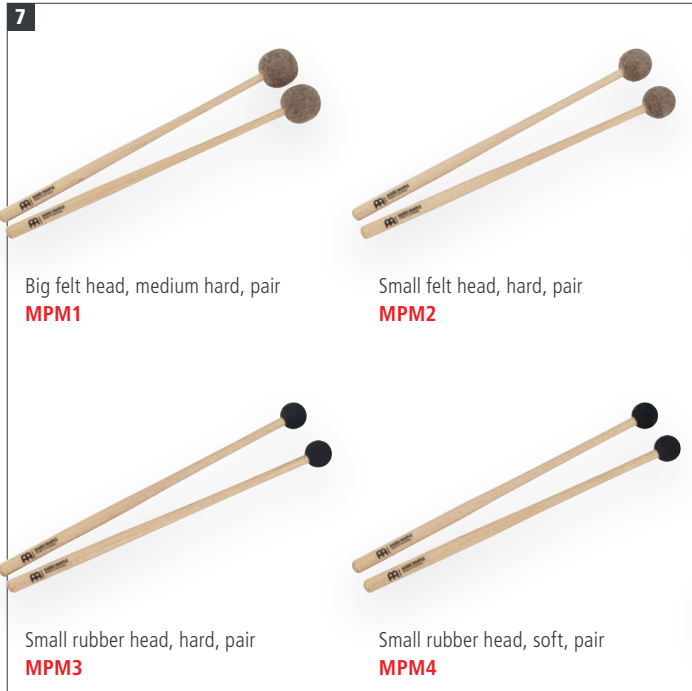

7 Big felt head, medium hard, pair
MPM1

8 Small felt head, hard, pair
MPM2

3 Small rubber head, hard, pair
MPM3

4 Small rubber head, soft, pair
MPM4



5 American Hickory, pair
MPM5



6 High-strength synthetic
COW5



1 Siam Oak
COW1

3BK Molded ABS
COW3BK

1BK Siam Oak
COW1BK

2 Siam Oak
COW2

PADDED
BEATER
SECTION



NEW

1-2 2" felt beater, pair
SB1-2

1 2" felt beater
SB1

2 2" felt beater
SB2

3 2 1/2" felt beater
SB3

4 2" leather beater
SB4

5 3" bushy felt beater
SB5



SBH

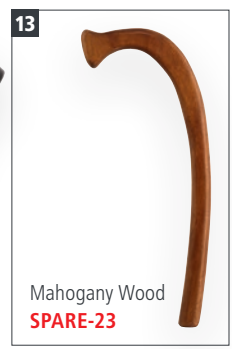

Mahogany Wood
SPARE-23



Wood
MGS1

ABS
MGS2

7 PERCUSSION MALLETS

SIZE 12 1/2" long
MATERIALS Hard maple
MPM1: Big felt head, medium hard
MPM2: Small felt head, hard
MPM3: Small rubber head, hard
MPM4: Small rubber head, soft
FEATURES Made out of the finest hand-selected maple; Great for woodblocks and synthetic percussion blocks; Made in Germany

8 TEMPLE & WOOD BLOCK MALLETS

SIZE 12 1/2" long
MATERIAL American Hickory
FEATURES Soft rubber mallet heads for wood blocks; Solid hickory handles

9 PALO COWBELL BEATER

SIZE 9 1/2" long
MATERIAL High-strength synthetic

FEATURES Cutting tone; High-strength; Balanced weight; Rubber grip; For live and studio

10 COWBELL BEATERS

MATERIALS **COW1, COW2:** Siam Oak (*Hevea brasiliensis* Muell.-Arg.)
COW3: Molded ABS
FEATURES Ribbed grip; Durable construction

11 SAMBA BEATERS

SIZES **SB1, SB1-2:** 15" long
SB2, SB3, SB4, SB5: 16" long
MATERIALS **SB1, SB1-2:** Solid aluminum stick with 2" felt beater
SB2: Wood stick with 2" felt beater
SB3: Wood stick with 2 1/2" felt beater
SB4: Wood stick with 2" leather beater
SB5: Wood stick with 3" bushy felt beater
FEATURE **SB1, SB1-2:** Comfortable foam grip

12 SURDO BEATER HOLDER

MATERIAL Leather
COLOR Black

13 TALKING DRUM BEATER

MATERIAL Mahogany Wood

14 GÜIRA SCRAPERS

MATERIALS Steel rods
MGS1: Ergonomic wooden grip
MGS2: Sanded ABS grip

BAGS

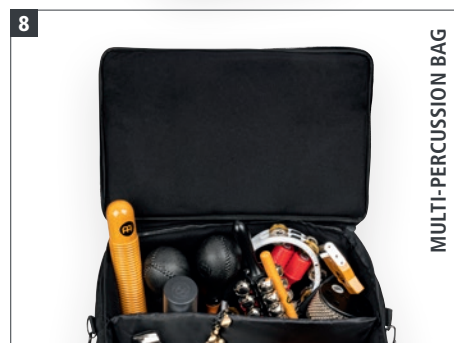

BAGS

MATERIAL Heavy-duty nylon (unless noted otherwise)

1 CAJON GIG BAG

SIZE 20 1/2" W x 12" H x 12" D

FEATURE Carrying grip

2 PROFESSIONAL CAJON BAGS

SIZES **MCJB:** 20 1/2" W x 12" H x 12" D

MCJB-L: 23 1/2" W x 17" H x 15" D

FEATURES Padded shoulder strap; External pocket; Carrying grip

MCJB-L: Fits bigger sized cajons

3 DELUXE CAJON BAG

SIZE 20 1/2" W x 12" H x 12" D

FEATURES Synthetic fur; Padded shoulder strap; External pocket; Carrying grip

4 DELUXE BASS PEDAL CAJON BAG

SIZE 21 1/2" W x 17" H x 14 1/2" D

FEATURES Synthetic fur; Padded shoulder strap; External pocket; Carrying grip

5 CAJON BACKPACK

SIZE 13 1/2" W x 19 3/4" H x 14" D

FEATURES Backpack; Carrying grip

6 JAM CAJON GIG BAG

SIZE 12" W x 16" H x 12" D

FEATURES Fits all Jam Cajon models; Strong carrying grip; Two-way zipper

7 TRAVEL CAJON GIG BAG

SIZE 12"

FEATURES Double-slide zipper; Carrying grip

8 MULTI-PERCUSSION BAG

SIZE 21" W x 12" H x 15" D

FEATURES Padded shoulder strap; External pocket; Carrying grip; Padded dividers

9 PROFESSIONAL SLAPTOP CAJON BAG

SIZE 23" W x 15" H x 13" D

FEATURES Padded shoulder strap; External pocket; Carrying grip

10 PROFESSIONAL HYBRID SLAPTOP CAJON BAG

SIZE 17 1/2" W x 13" H x 8" D

11 STANDARD DJEMBE BAGS

SIZES **MSTDJB10:** Medium (10")

MSTDJB12: Large (12")

FEATURES External pocket; Carrying grip

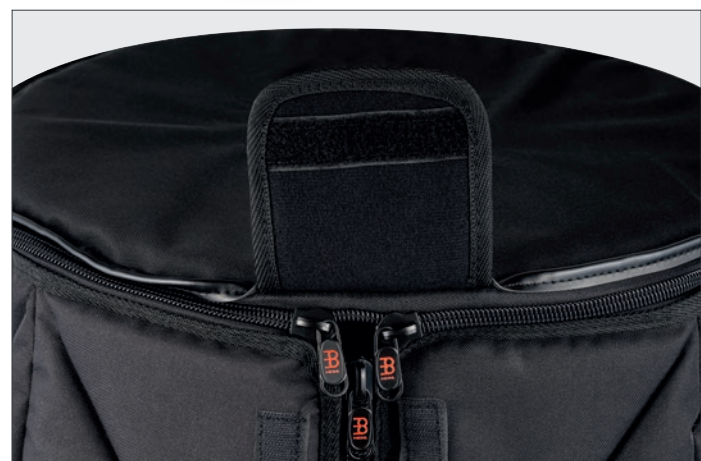

12 PROFESSIONAL DJEMBE BAGS
SIZES **S:** Small (up to 10")
M: Medium (up to 12")
L: Large (up to 13 1/2")
XL: XL: Extra large (up to 14")
FEATURES External pocket; Carrying grip
MDJB-M, MDJB-L, MDJB-XL:
 Padded backpack straps

13 DJEMBE GIG BAG
FEATURES Carrying grip; Shoulder strap;
 Outer pocket

14 PROFESSIONAL DJEMBE CAPS
SIZES **M:** 10"; **L:** 12"; **XL:** 13"

15 CONGA GIG BAG
FEATURES Carrying grip; Shoulder strap; Outer pocket

16 PROFESSIONAL CONGA BAGS
SIZES **MCOB-11:** 11"
MCOB-1134: 11 3/4"
MCOB-1212: 12 1/2"
FEATURES Additional upright zipper; External pocket;
 Padded backpack straps; Carrying grip

17 POP OFF CONGA SET BAG
SIZE 13" x 26"
FEATURES Carrying handle with reinforced nylon
 stitching; Durable zipper; Adjustable
 backpack straps; Carry all three sizes of
 Meinl Pop Off Congas

BAGS



BAGS

MATERIAL Heavy-duty nylon (unless noted otherwise)

1 BONGO GIG BAG

SIZE Bongos up to 7 1/2" Macho & 8 1/2" Hembra
FEATURE Carrying grip

2 PROFESSIONAL BONGO BAG

FEATURES Additional room for accessories; Padded shoulder strap; Carrying grip; Padded separator

3 PROFESSIONAL TIMBALES BAG

SIZE 14" & 15"
FEATURES External pocket for stand and cowbell; Padded shoulder strap; Carrying grip; Padded separator

4 PROFESSIONAL SURDO BAGS

SIZES **MSUB-16:** 16" x 20"
MSUB-18: 18" x 22"
MSUB-20: 20" x 24"
MSUB-22: 22" x 24"

FEATURES Double-slide zipper; Padded backpack straps; Carrying grip; External pocket

5 PROFESSIONAL TIMBA BAGS

SIZES **MTIMB-1428:** 14" x 28"
MTIMB-1435: 14" x 35"

FEATURES Double-slide zipper; Padded backpack straps; Carrying grip; External pocket

6 POP OFF BASS DRUM SET BAG

SIZE 16 1/4" x 25 1/4"
FEATURES Carrying handle with reinforced nylon stitching; Durable zipper; Adjustable backpack straps; Carry all three sizes of Meinl Pop Off Bass Drums

7 PROFESSIONAL TANTAM BAG

SIZE 14" x 28"
FEATURES Double-slide zipper; Padded backpack straps; Carrying grip; External pocket

8 PROFESSIONAL REBOLO BAG

SIZE 12" x 18"
FEATURES Double-slide zipper; Padded shoulder strap; Carrying grip; External pocket

9 PROFESSIONAL REPINIQUE BAGS

SIZES **MREB-10:** 10" x 10"
MREB-12: 12" x 12"
FEATURES Double-slide zipper; Shoulder strap; Carrying grip; External pocket

9
PRO REPINIQUE BAGS
MREB-10 MREB-12

10
PRO CUIÇA BAGS
MQW-6 MQW-10

11
PRO CAIXA BAGS
MCA-12 MCA-12T MCA-14

12
PRO CHIMES BAG
MCHB

13
PRO FRAME DRUM BAGS
MFDB-14 MFDB-16 MFDB-18 MFDB-20 MFDB-22

14
PRO DEEP SHELL FRAME DRUM BAGS
MFDB-14BE MFDB-14IBO MFDB-18BO MFDB-22-D

15
PRO PANDEIRO BAGS
MPAB-10 MPAB-12

16
TAMBOURINE GIG BAG
MSTTB

17
PRO TAMBORIM BAG
MTAB-06

18
PRO KANJIRA BAG
MFDB-7KA

10 PROFESSIONAL CUIÇA BAGS
SIZES **MQW-6:** 6"
 MQW-10: 10"
FEATURES Padded shoulder strap; Carrying grip;
 External pocket

11 PROFESSIONAL CAIXA BAGS
SIZES **MCA-12:** 12" x 4 1/2"
 MCA-12T: 12" x 6"
 MCA-14: 14" x 4"
FEATURES Double-slide zipper; Shoulder strap;
 Extra pocket for spare heads;
 Carrying grip; External pocket

12 PROFESSIONAL CHIMES BAG
FEATURES Stores up to 2 chimes; Carrying grip;
 Inner hook and loop fastener straps;
 2 internal pockets

13 PROFESSIONAL FRAME DRUM BAGS
SIZES **MFDB-14:** 14", 2 1/2" deep
 MFDB-16: 16", 2 1/2" deep
 MFDB-18: 18", 2 1/2" deep
 MFDB-20: 20", 2 1/2" deep
 MFDB-22: 22", 2 1/2" deep
FEATURES Double-slide zipper; Shoulder strap;
 Carrying grip

14 PROFESSIONAL DEEP SHELL FRAME DRUM BAGS
SIZES **MFDB-14BE:** 14" x 4"
 MFDB-14IBO: 14" x 6"
 MFDB-18BO: 18" x 4"
 MFDB-22-D: 22" x 4"
FEATURES Double-slide zipper; Shoulder strap;
 Carrying grip

15 PROFESSIONAL PANDEIRO BAGS
SIZES **MPAB-10:** 10"; **MPAB-12:** 12"
FEATURES Double-slide zipper; Shoulder strap;
 External pocket
 MPAB-12: Also fits for our
 10" Tambourines

16 TAMBOURINE GIG BAG
SIZE 10"
FEATURES Sturdy zipper; Carrying grip

17 PROFESSIONAL TAMBORIM BAG
SIZE 6"
FEATURES Double-slide zipper; Shoulder strap;
 External pocket

18 PROFESSIONAL KANJIRA BAG
SIZE 8 1/2" x 2 1/2"
FEATURES Double-slide zipper; Shoulder strap;
 External pocket

BAGS



BAGS

MATERIAL Heavy-duty nylon
(unless noted otherwise)

1 STANDARD DARBUKA BAG

SIZE Medium
FEATURES Carrying grip; Shoulder strap; Outer pocket

2 PROFESSIONAL DARBUKA BAG

FEATURES Double-slide zipper; Additional upright zipper; Padded shoulder strap; Carrying grip; External pocket

3 PROFESSIONAL IBO BAGS

SIZES **S:** Small (9 3/4" W x 13 1/3" H x 9 3/4" D)
M: Medium (11" W x 14 1/2" H x 11" D)
L: Large (11 3/4" W x 15" H x 11 3/4" D)
FEATURES Padded shoulder strap; Carrying grip; External pocket

4 STANDARD DOUMBЕК BAG

SIZE Medium
FEATURES Carrying grip; Shoulder strap; Outer pocket

5 PROFESSIONAL DOUMBЕК BAGS

SIZES **MDOB:** Medium
MDOB-L: Large
FEATURES Double-slide zipper; Additional upright zipper; Padded shoulder strap; Carrying grip; External pocket

6 STRAIGHT DIDGERIDOO BAG

SIZE 53"
FEATURES Padded shoulder strap; External pocket

7 PRO DIDGERIDOO BAG

SIZE 58"
FEATURES Padded shoulder strap; External pocket

8 PERCUSSION BACKPACK

MATERIAL Ripstop Fabric
FEATURES Travel backpack for small percussion instruments; Numerous pockets on the inside and outside; Padded backpack shoulder straps; Carrying grip
FINISH Carbon Grey

9 HAND PERCUSSION BAGS

SIZES **M:** Medium
L: Large
FEATURES Great for cowbells, blocks or small hand percussion; Drawstring top; Durable nylon prevents scuffs and scratches; No hassle storage or travel

10 COMPACT STICK BAG

FEATURE Carrying grip

BAGS & DRUM RUGS



10 COMPACT STICK BAG

MCSB



11 PROFESSIONAL STICK BAG

MSB-1



12 DELUXE STICK BAG

MDLXSB



13 STICK SLING BAG

MSSB



14 DRUM RUGS

Black, small
MDRS-BK

Black, large
MDRL-BK

Oriental, small
MDRS-OR

Oriental, large
MDRL-OR

11 PROFESSIONAL STICK BAG

FEATURES External pockets; Shoulder straps; Extension straps
COLOR Black

12 DELUXE STICK BAG

MATERIAL Padded synthetic leather
FEATURES External pockets; Shoulder straps; Elastic cord attachments

13 STICK SLING BAG

FEATURES Wider version of our Professional Stick Bag; Eleven internal pockets of varying size for any kind of stick, mallet, rod, brush or accessory; Oversized exterior pocket that can fit books, sheet music, practice pads or metronomes

14 DRUM RUGS

SIZES **MDRS:** 5.25 ft (160 cm) x 4.6 ft (140 cm)
MDRL: 6.5 ft (200 cm) x 6.5 ft (200 cm)

MATERIAL Woven fabric

FEATURES **MDRS** Tightly woven fabric creates a strong grip with spurs and stands; Durable no-slip rubber bottom; Compact size for smaller drum or percussion setups; Ideal for smaller stage footprint
MDRL

Durable no-slip rubber bottom; Full-size for any drum or percussion setup; Ideal for drum risers

INCLUDES Travel bag
Strap

FINISHES **BK:** Black
OR: Oriental

MEINL PERCUSSION ONLINE

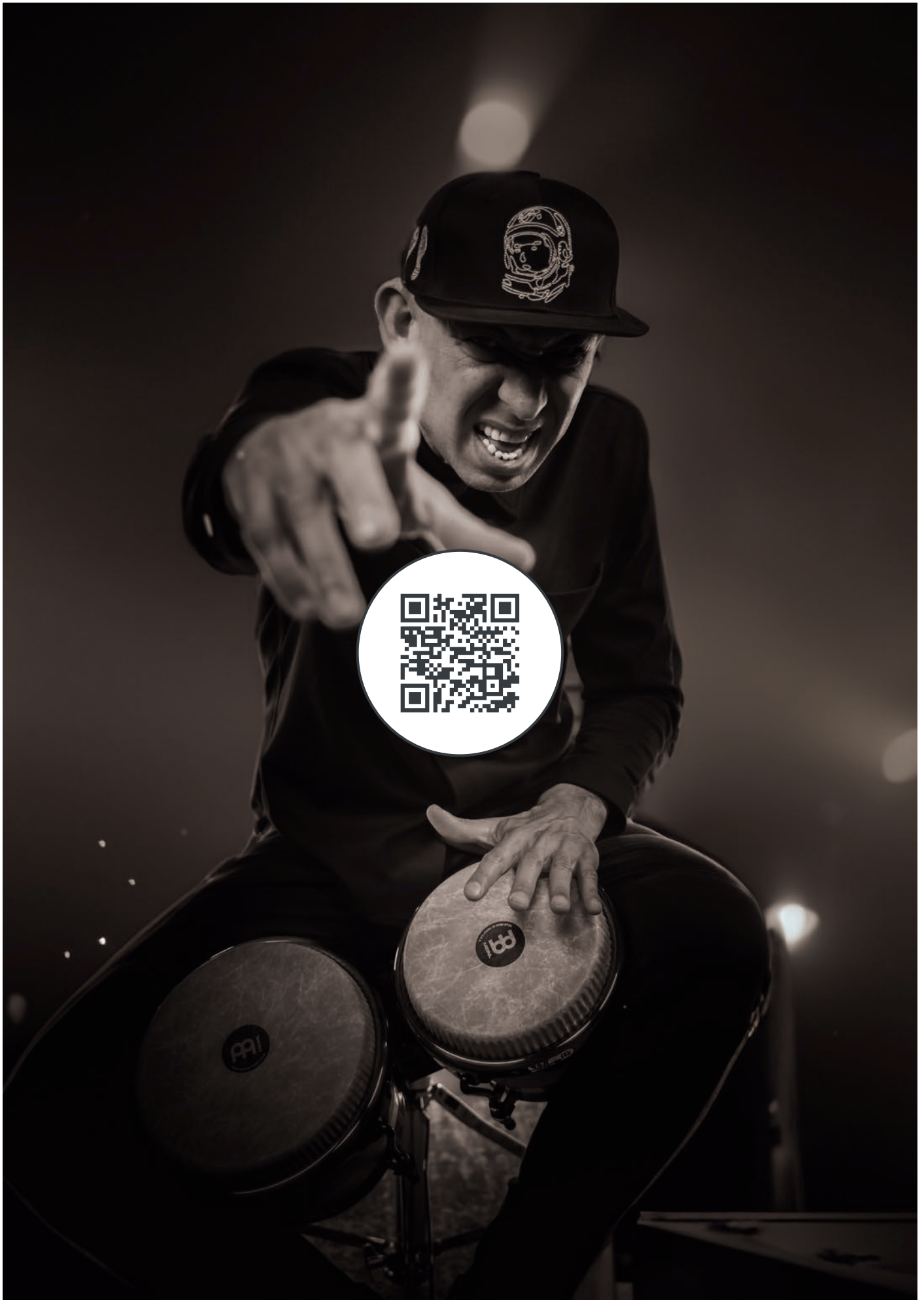

DISCLAIMER

All features are subject to change without notice. Not responsible for typographic errors. No part of this book may be reprinted, reproduced, or included in any online service in any form in whole or in part, without the prior permission of Meinel.

© 2026 Roland Meinel Musikinstrumente GmbH & Co. KG

ADVERTISING CONCEPT & DESIGN

ercas GmbH & Co. KG [ercasdieagentur.de]

CONTENT & DIRECTION

Hannes Auerochs, Udo Heubeck

COPYWRITING

Hannes Auerochs, Ayrton Gauerke

PHOTOGRAPHY

Christian Habermeier, Sebastian Jäger, Angelika Jakobs
[studio-waldeck.de]

Miroslav Šmikmátor [smikmatorphoto.com]

AWF STUDIOS

Tobias Winklmann, Danny Lucenara, Hannes Auerochs,
Jan Potsch, Niklas Sakowski, Thomas Bönig, Paul
Höppner, Mario Schmitt, William De La Cruz, Dennis
Ostermann, Rüdiger Knuth

LITHOGRAPHY

Sven Mihm [mihm-werbung.de]

GLOBAL HEADQUARTERS

Roland Meinel Musikinstrumente GmbH & Co. KG
Musik-Meinel-Straße 1
91468 Gutenstetten
Germany

US HEADQUARTERS

Meinel USA L.C.
3427 Ambrose Avenue
Nashville, TN 37207
USA

INVENTORS OF SELECTED PRODUCTS

Bill Saragosa

Dany Moreno

Gilson Batista Da Silveira

José J. Cortijo

Juan Carlos Melian

Marcus Ralph De Mowbray

Mark Allen Johnson

Michael Buchner

Reiko Guthschmidt

Taku Hirano

Torsten Franz

REMO®, Fiberskyn®, Nuskyn® and Skyndeep®
are registered trademarks of REMO® Inc.
Used by permission.

This catalogue has been printed on
climate neutral paper.

Printed in Germany M-CA101025

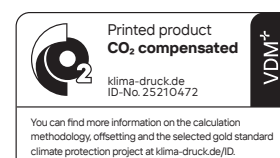



8 42960 15597 6

Daoud DEBU